

■ Célula de carga de cizallamiento

■ Versiones:

- **350i** (300...5000kg): Totalmente en acero inox. Sellado hermético, completamente soldada, IP 68 (EN 60529) e IP 69K (ISO 20653)
- **350a** (300...5000kg): Construcción en acero inox. Sellado silicona, IP 66 (EN 60529)
- **350n** (300...2000kg): Construcción en acero niquelado. Sellado silicona, IP 66 (EN 60529)

■ 3000 divisiones OIML R60 clase C

■ Preajuste de esquinas optimizado para sistemas multicélulas

■ Disponible en versión **ATEX** (opcional)
Zona 0-1-2 (gas) y 20-21-22 (polvo)

■ Aplicaciones industriales de alta precisión:

- plataformas con 4 células
- reactores, tanques y tolvas

■ Shear beam load cell

■ Versions:

- **350i** (300...5000kg): Fully Stainless Steel construction. Hermetically sealed, fully welded, IP 68 (EN 60529) and IP 69K (ISO 20653)
- **350a** (300...5000kg): Stainless Steel construction. Silicone sealing, IP 66 (EN 60529)
- **350n** (300...2000kg): Nickel-plated Alloy Steel. Silicone sealing, IP 66 (EN 60529)

■ 3000 divisions OIML R60 class C

■ Pre-corner adjustment optimized for multicell systems

■ Available in **ATEX** version (optional)
Zone 0-1-2 (gas) and 20-21-22 (dust)

■ High accuracy on industrial applications:

- four load cells platforms
- tanks and hoppers weighing

Modelo Model	Carga nominal Nominal capacity Ln	Clase de precisión Accuracy class n. OIML	División mínima Minimum division vmin	Carga de servicio Service load 150 % Ln	Carga límite Safe load 200 % Ln
350 300 kg	300 kg	3000	30 g	450 kg	600 kg
350 500 kg	500 kg	3000	50 g	750 kg	1000 kg
350 750 kg	750 kg	3000	75 g	1125 kg	1500 kg
350 1000 kg	1000 kg	3000	100 g	1500 kg	2000 kg
350 1500 kg	1500 kg	3000	150 g	2250 kg	3000 kg
350 2000 kg	2000 kg	3000	200 g	3000 kg	4000 kg
350 3000 kg	3000 kg	3000	300 g	4500 kg	6000 kg
350 5000 kg	5000 kg	3000	500 g	7500 kg	10000 kg

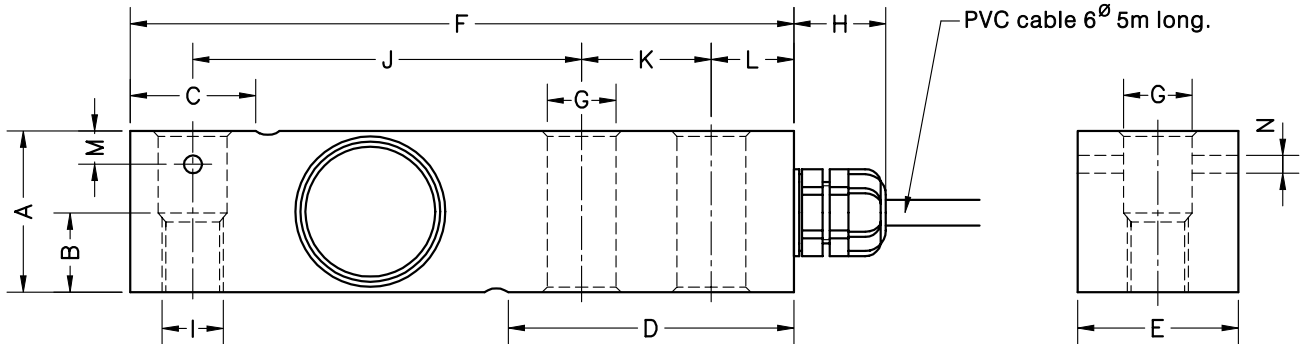
Mod. 350i/a (300...5000kg)
Mod. 350n (300...2000kg)

Carga nominal Nominal load	A	B	C	D	E	F	GØ	H	I	J	K	L	M	NØ	Peso transporte Transport weight
300-500-750-1000-1500-2000 kg	31.5	15	24.6	56	31.5	130	13.5	18	M12	76.2	25.4	15.8	6.5	3.5	0.9 kg
3000-5000 kg	48	-	37	76	41.5	171.5	20.5	18	-	95.2	38.1	19	-	-	2.2 kg

 Dimensiones en mm. *Dimensions in mm.*

ESPECIFICACIONES			SPECIFICATIONS
Cargas nominales (Ln)	300-500-750-1000-1500-2000-3000-5000	kg	Nominal capacities (Ln)
Clase de precisión	3000	n. OIML	Accuracy class
Carga mínima	0	%Ln	Minimum dead load
Carga de servicio	150	%Ln	Service load
Cargas límite	200	%Ln	Safe load limit
Error combinado	< ±0.017	%Sn (1)	Total error
Error repetibilidad	< ±0.015	%Sn	Repeatability error
Efecto de la temperatura: en el cero	< ±0.01	%Sn/5 °C	Temperature effect: on zero
en la sensibilidad	< ±0.006	%Sn/5 °C	on sensitivity
Error de fluencia (30 minutos)	< ±0.016	%Sn	Creep error (30 minutes)
Compensación de temperatura	-10...+40	°C	Temperature compensation
Límites de temperatura	-30...+70	°C	Temperature limits
Sensibilidad nominal (Sn)	2	mV/V (2)	Nominal sensitivity (Sn)
Tensión de alimentación nominal	10	V	Nominal input voltage
Tensión de alimentación máxima	15	V	Maximum input voltage
Resistencia de entrada	400 ±20	Ω	Input impedance
Resistencia de salida	350 ±3	Ω	Output impedance
Desequilibrio inicial	< ±2	%Sn	No load output
Resistencia de aislamiento	> 5000	MΩ	Insulation resistance
Deformación máxima (a Ln)	0.2-0.4	mm	Maximum deflection (at Ln)

 CONEXIÓN ELÉCTRICA
ELECTRICAL CONNECTION:

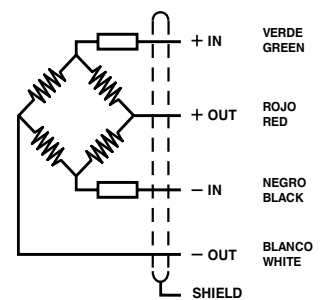
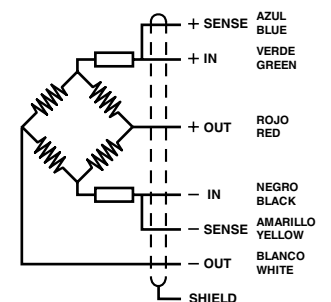
MOD. 350a/350n

MOD. 350i

(1) Error combinado: No Linealidad e Histéresis / Total error: Non Linearity and Hysteresis

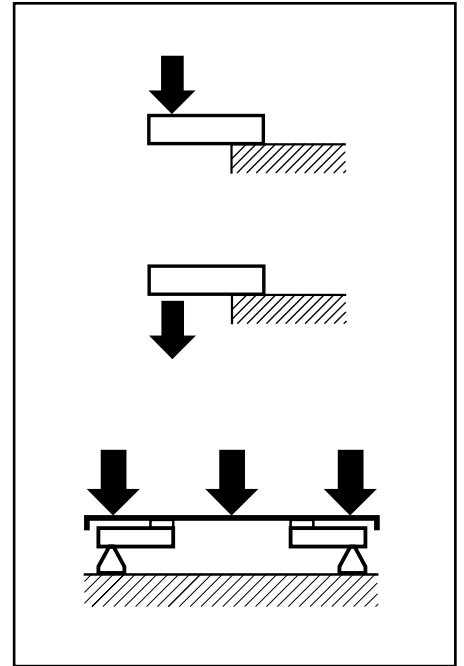
 (2) Preajuste de esquinas optimizado al ±0.05% mediante la calibración de la corriente de salida /
Pre-corner adjustment optimized at ±0.05% by output current calibration



- Célula de carga de cizallamiento
- Totalmente en acero inoxidable
- Sellado hermético, completamente soldada
- Protección IP 68 (EN 60529) e IP 69K (ISO 20653)
- 3000 divisiones OIML R60 clase C
- Preajuste de esquinas optimizado para sistemas multicélulas
- Aplicaciones industriales de alta precisión:
 - plataformas con 4 células
 - reactores, tanques y tolvas
 - básculas puente para vehículos ligeros
 - pesaejes
 - pesaje "on-board"
- Disponible en versión **ATEX** (opcional)
Zona 0-1-2 (gas) y 20-21-22 (polvo)

- Shear beam load cell
- Fully Stainless Steel construction
- Hermetically sealed, fully welded
- Protected IP 68 (EN 60529) and IP 69K (ISO 20653)
- 3000 divisions OIML R60 class C
- Pre-corner adjustment optimized for multicell systems
- High accuracy on industrial applications:
 - four load cells platforms
 - tanks and hoppers weighing
 - light vehicle weighbridges
 - axle weighing
 - "on-board" weighing
- Available in **ATEX** version (optional)
Zone 0-1-2 (gas) and 20-21-22 (dust)

Modelo Model	Carga nominal Nominal capacity Ln	Clase de precisión Accuracy class n. OIML	División mínima Minimum division vmin	Carga de servicio Service load 150 % Ln	Carga límite Safe load 200 % Ln
350 7500 kg	7500 kg	3000	0.75 kg	11250 kg	15000 kg
350 10000 kg	10000 kg	3000	1 kg	15000 kg	20000 kg

MODELO 350 (7500...10000kg)

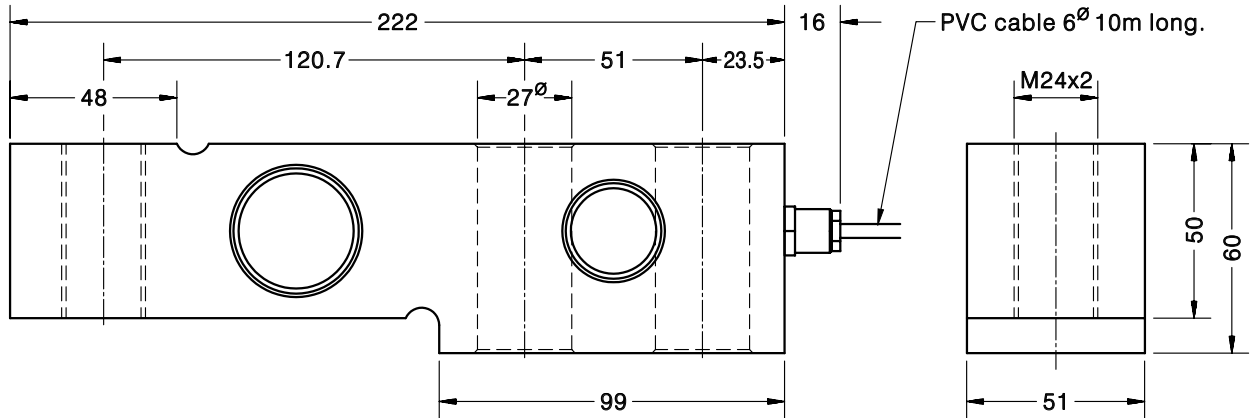

Dimensiones en mm. *Dimensions in mm.*

Peso transporte - *Transport weight:* 4.3 kg

ESPECIFICACIONES			SPECIFICATIONS
Cargas nominales (Ln)	7500-10000	kg	Nominal capacities (Ln)
Clase de precisión	3000	n. OIML	Accuracy class
Carga mínima	0	%Ln	Minimum dead load
Carga de servicio	150	%Ln	Service load
Cargas límite	200	%Ln	Safe load limit
Error combinado	< ±0.017	%Sn (1)	Total error
Error repetibilidad	< ±0.015	%Sn	Repeatability error
Efecto de la temperatura: en el cero	< ±0.01	%Sn/5 °C	Temperature effect: on zero
en la sensibilidad	< ±0.006	%Sn/5 °C	on sensitivity
Error de fluencia (30 minutos)	< ±0.016	%Sn	Creep error (30 minutes)
Compensación de temperatura	-10...+40	°C	Temperature compensation
Límites de temperatura	-30...+70	°C	Temperature limits
Sensibilidad nominal (Sn)	2	mV/V (2)	Nominal sensitivity (Sn)
Tensión de alimentación nominal	10	V	Nominal input voltage
Tensión de alimentación máxima	15	V	Maximum input voltage
Resistencia de entrada	400 ±20	Ω	Input impedance
Resistencia de salida	350 ±3	Ω	Output impedance
Desequilibrio inicial	< ±2	%Sn	No load output
Resistencia de aislamiento	> 5000	MΩ	Insulation resistance
Deformación máxima (a Ln)	0.2-0.4	mm	Maximum deflection (at Ln)

CONEXIÓN ELÉCTRICA ELECTRICAL CONNECTION:

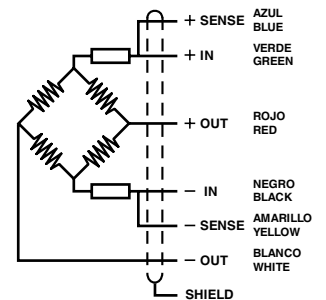

«SENSES»: 2 hilos adicionales, para mantener constante la alimentación en la célula, con una instrumentación adecuada. Utilizar especialmente para cables largos y amplio margen de temperatura.
PANTALLA: No conectada al cuerpo del transductor.

«SENSES»: 2 additional wires to maintain a constant voltage supply at the load cell when used with proper instrumentation. Use specially when long wires and wide temperature range.
SHIELD: Not connected to transducer body.

(1) Error combinado: No Linealidad e Histéresis / Total error: Non Linearity and Hysteresis

(2) Preajuste de esquinas optimizado al ±0.05% mediante la calibración de la corriente de salida / Pre-corner adjustment optimized at ±0.05% by output current calibration

ACCESORIO PIE AUTOCENTRANTE PARA MOD. 340-350
LOAD FOOT ACCESSORY FOR MODELS 340-350

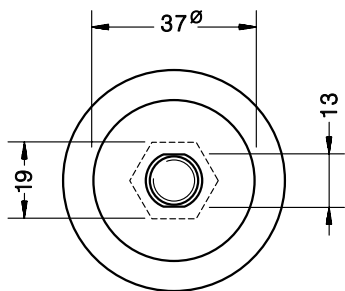
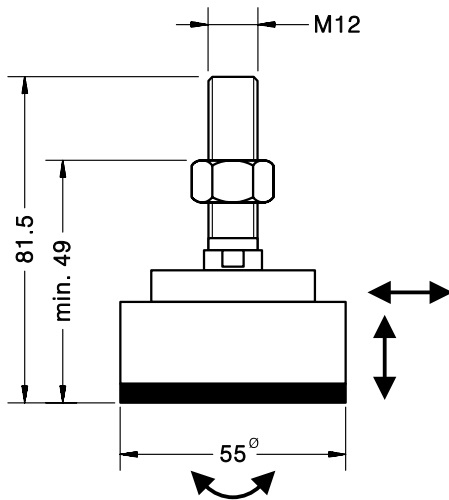

- **Materiales: acero inoxidable y goma natural**
- **Materials: Stainless Steel and Rubber**

Acc. 35901 para Mod. 350 (300...2000 kg) / For Mod. 350 (300...2000 kg)

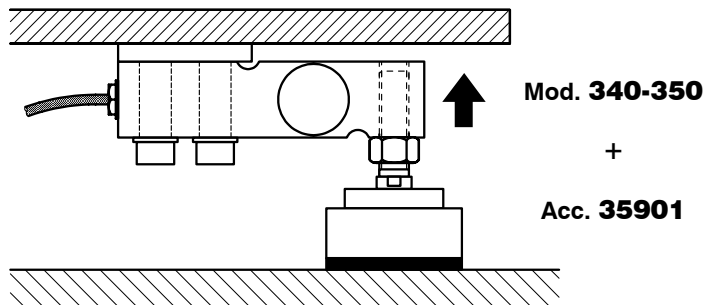
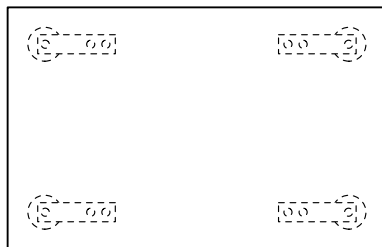

Dimensiones en mm. *Dimensions in mm.*

Peso transporte - *Transport weight:* 0.33 kg

**ACCESORIO PIE AUTOCENTRANTE PARA MOD. 340-350
LOAD FOOT ACCESSORY FOR MODELS 340-350**

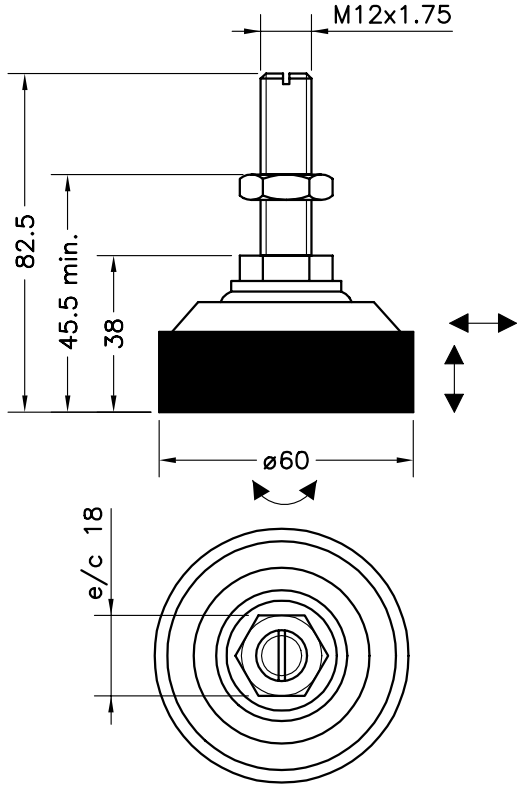

■ **Materiales: acero inoxidable y goma natural**

■ **Materials: Stainless Steel and Rubber**

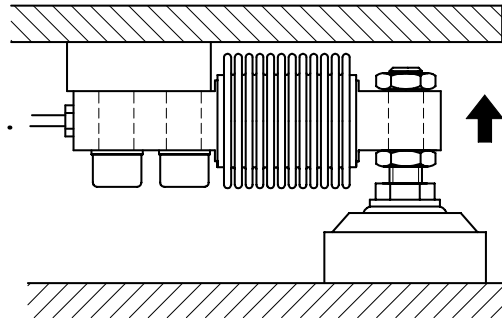
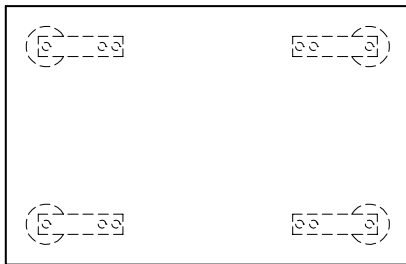
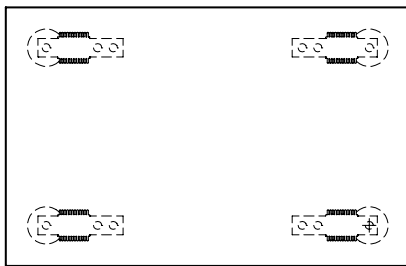

Mod. 340
+
Acc. FT12i

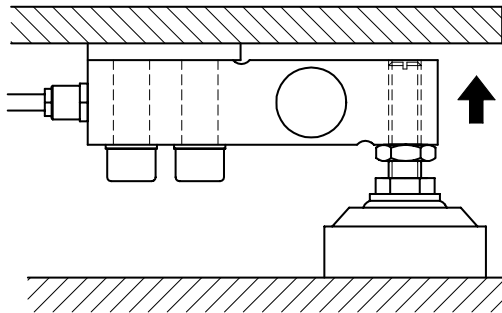

Mod. 350
(300...2000 kg)
+
Acc. FT12i

Dimensiones en mm. *Dimensions in mm.*

Peso transporte - *Transport weight:* 0.42 kg

SOPORTE TANQUES CON ANTIVUELCO PARA MOD. 350

MOUNTING-KIT LIFT-OFF PREVENTION FOR MOD. 350

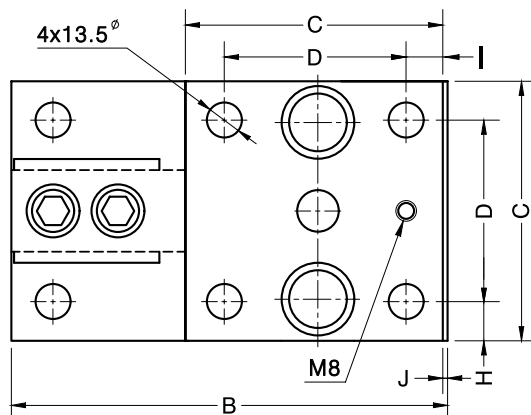
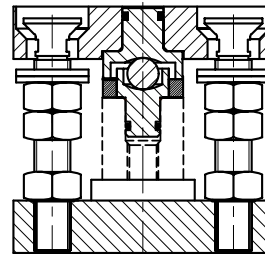
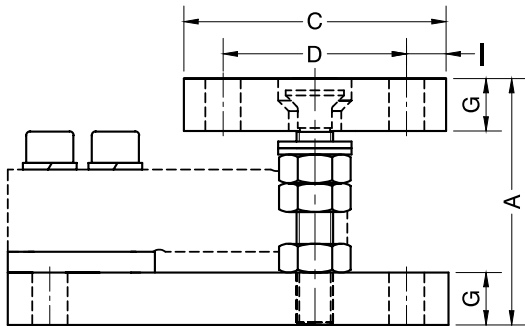
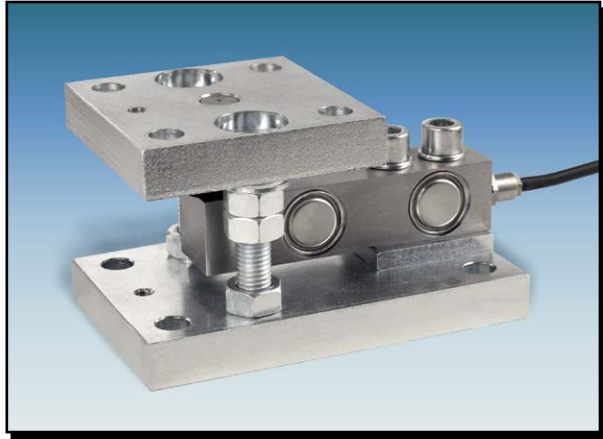
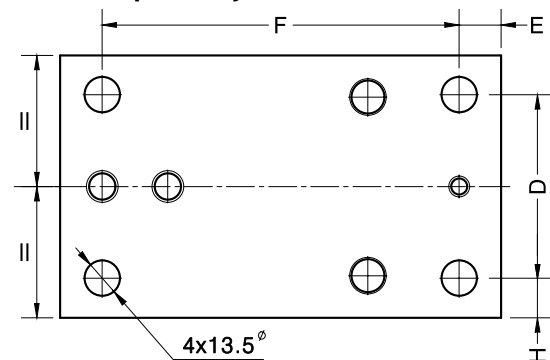
Material:
Acero cincado **Acc. 35902-35903**
Acero inoxidable **Acc. 35902i-35903i**
Material:
Alloy Steel zinc-plated **Acc. 35902-35903**
Stainless Steel **Acc. 35902i-35903i**

Vista por abajo / View from below

Accesorio Accessory	Carga nominal Nominal load	A	B	C	D	E	F	G	H	I	J	Peso transporte Transport weight
35902	0.3...2 t	94	168	100	70	16	136	20	15	15	1	5 kg
35903	3...5 t	113	212	120	84	18	175	25	18	18	-	8.5 kg

	Acero cincado / Alloy Steel zinc-plated		Acero inoxidable / Stainless Steel	
	35902	35903	35902i	35903i
Máximo desplazamiento horizontal <i>Maximum horizontal offset</i>	±2.5 mm	±2 mm	±2.5 mm	±2 mm
Máxima fuerza de levantamiento <i>Maximum lift-off force</i>	69 kN	113.04 kN	69 kN	113.04 kN
Máxima fuerza horizontal <i>Maximum horizontal force</i>	7.93 kN	11.8 kN	5 kN	11.8 kN

 Dimensiones en mm. *Dimensions in mm.*

ACCESORIO TRACCION PARA MODELO 350
TENSION ACCESSORY FOR MODEL 350

Acc. 35907 (0.3...2t)

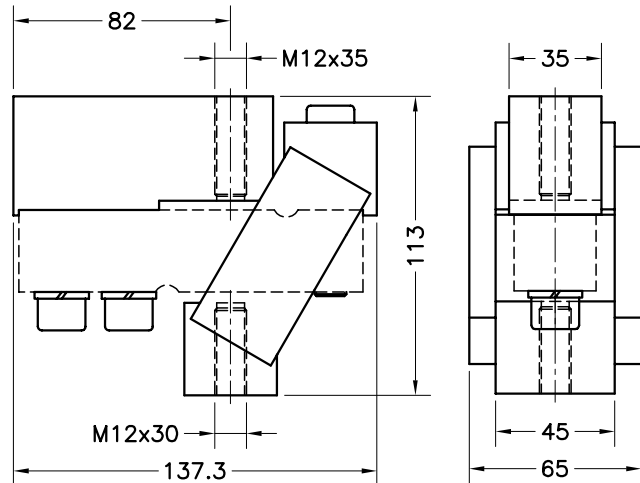

- **Material: Acero cincado / Material: Alloy Steel zinc-plated**
- **Carga límite: 4000 kg / Ultimate load: 4000 kg**

Dimensiones en mm. *Dimensions in mm.*

Peso transporte - *Transport weight: 2.5 kg*

Acc. 35908 (3...5t)

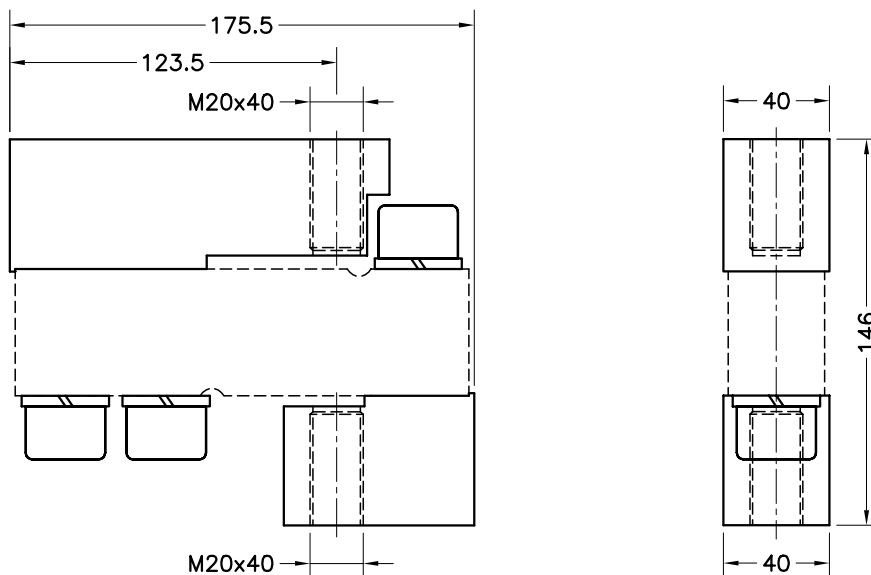

- **Material: Acero cincado / Material: Alloy Steel zinc-plated**
- **Carga límite: 10000 kg / Ultimate load: 10000 kg**

Dimensiones en mm. *Dimensions in mm.*

Peso transporte - *Transport weight: 3.8 kg*

KIT TANQUES SILENT-BLOCK ANTIVUELCO PARA MOD. 350

TANK KIT SILENT-BLOCK LIFT-OFF PREVENTION FOR MOD. 350

- **Material: Acero cincado - goma Acc. 359xx**
Acero inox. - goma Acc. 359xxi

- **Material: Alloy Steel zinc-plated - Rubber**
Acc. 359xx
Stainless Steel - Rubber
Acc. 359xxi

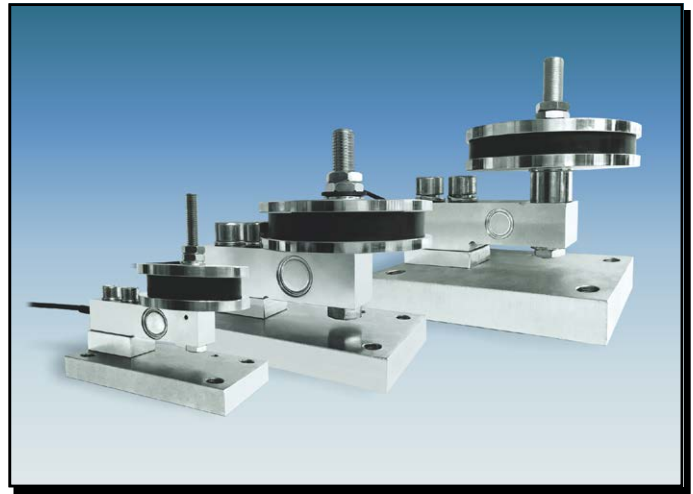

Acc. 35909-35910-35918: Con silent-block antivuelco / Silent-block with lift-off prevention

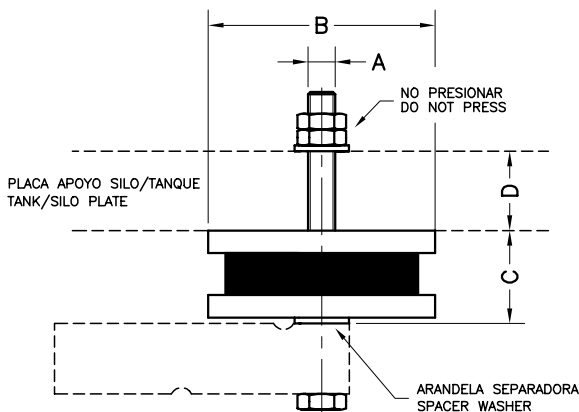

Accesorio Accessory	Carga Nominal Load	A	B \varnothing	C	D	Peso Transport Weight
35909	0.3...2 t	M12	100	41	0...35	2 kg
35910	3...5 t	M20	150	44	10...35	3.2 kg
35918	7.5...10 t	M24	200	84	0...50	7.8 kg

Acc. 35911-35912-35919: Placa base / Base plate

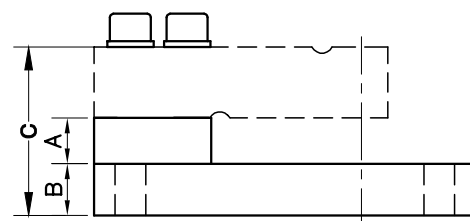
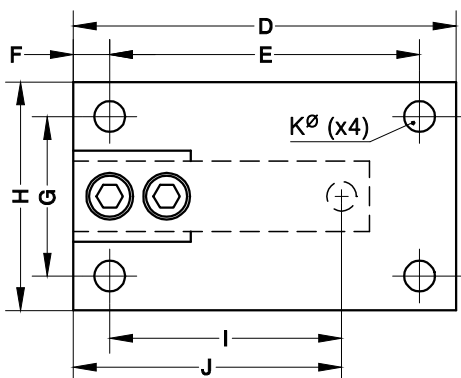

Accesorio Accessory	Carga Nominal Load	A	B	C	D	E	F	G	H	I	J	K \varnothing	Peso Transport Weight
35911	0.3...2 t	20	20	71.5	168	136	16	70	100	101.6	117.6	13.5	3.2 kg
35912	3...5 t	20	25	93	212	175	19	84	120	133.3	152.3	13.5	5.8 kg
35919	7.5...10 t	20	40	120	285	235	25.5	127	180	171.7	197.2	21	17.5 kg

Dimensiones en mm. *Dimensions in mm.*

ACCESORIO PIE AUTOCENTRANTE PARA MOD. 350
LOAD FOOT ACCESSORY FOR MODELS 350

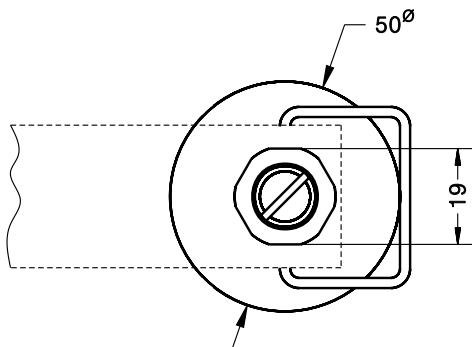
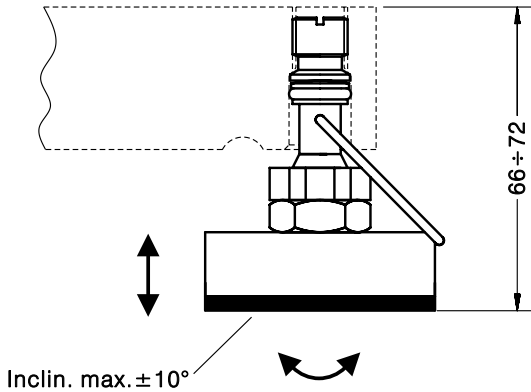

■ **Materiales:** Acero cincado y goma natural
Acc. 35913

Acero inox. y goma natural
Acc. 35913i

■ **Materials:** Alloy Steel zinc-plated and Rubber
Acc. 35913

Stainless Steel and Rubber
Acc. 35913i

Acc. 35913 para Mod. 350 (300...2000 kg) / For Mod. 350 (300...2000 kg)

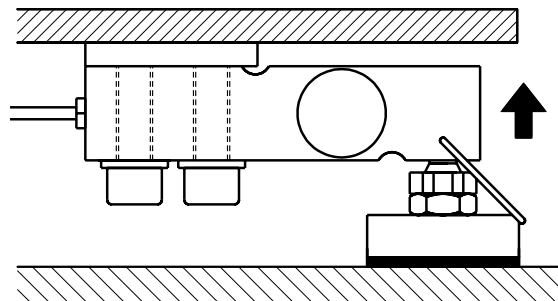
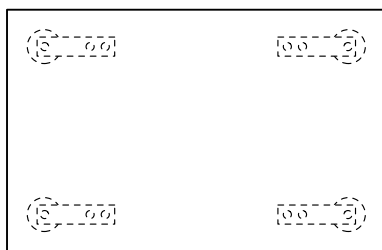

Mod. 350

+

Acc. 35913

Dimensiones en mm. *Dimensions in mm.*

Peso transporte - *Transport weight:* 0.29 kg

ACCESORIO PIE AUTOCENTRANTE PARA MOD. 350
LOAD FOOT ACCESSORY FOR MODEL 350

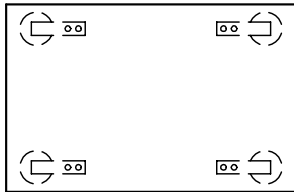

Mod. 350
+
Acc. 35917i

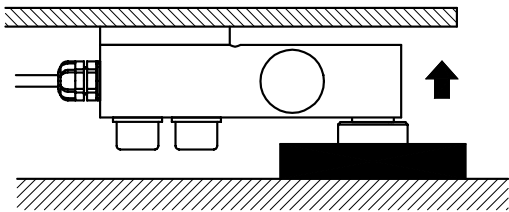

- **Materiales: acero inoxidable y goma**
- **Materials: Stainless Steel and Rubber**

Acc. 35917i para Mod. 350 (3 - 5 t) / For Model 350 (3 - 5 t)

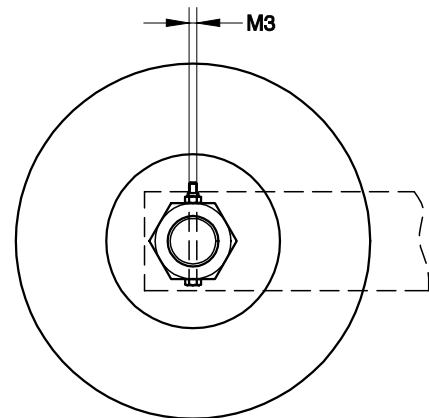
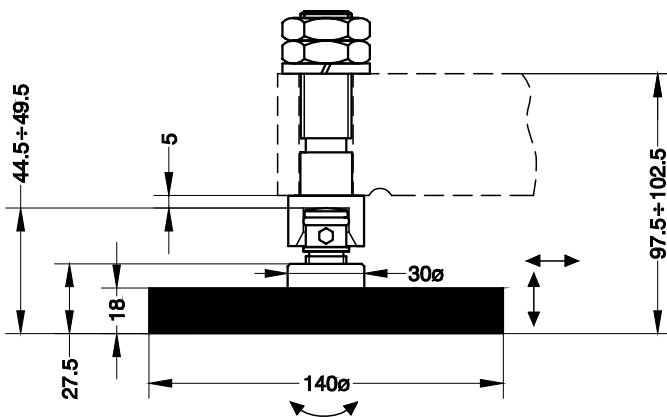

Dimensiones en mm. *Dimensions in mm.*

Peso transporte - *Transport weight:* 1.3 kg

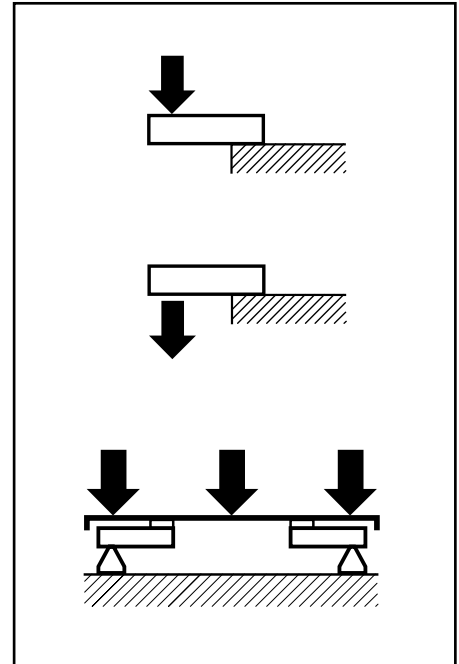

- Célula de carga de cizallamiento
- Opción T para modelo 350 con taladro de carga ciego
- Versiones:
 - **350Ti**: Totalmente en acero inox. Sellado hermético, completamente soldada, IP 68 (EN 60529) e IP 69K (ISO 20653)
 - **350Ta**: Construcción en acero inox. Sellado silicona, IP 66 (EN 60529)
- 3000 divisiones OIML R60 clase C
- Preajuste de esquinas optimizado para sistemas multicélulas
- Disponible en versión **ATEX** (opcional) Zona 0-1-2 (gas) y 20-21-22 (polvo)
- Aplicaciones industriales de alta precisión especialmente para plataformas con 4 células

- Shear beam load cell
- Option T for model 350 with blind loading hole
- Versions:
 - **350Ti**: Fully Stainless Steel construction. Hermetically sealed, fully welded, IP 68 (EN 60529) and IP 69K (ISO 20653)
 - **350Ta**: Stainless Steel construction. Silicone sealing, IP 66 (EN 60529)
- 3000 divisions OIML R60 class C
- Pre-corner adjustment optimized for multicell systems
- Available in **ATEX** version (optional) Zone 0-1-2 (gas) and 20-21-22 (dust)
- High accuracy on industrial applications specially for four load cells platforms

Modelo Model	Carga nominal Nominal capacity Ln	Clase de precisión Accuracy class n. OIML	División mínima Minimum division vmin	Carga de servicio Service load 150 % Ln	Carga límite Safe load 200 % Ln
350 300 kg	300 kg	3000	30 g	450 kg	600 kg
350 500 kg	500 kg	3000	50 g	750 kg	1000 kg
350 750 kg	750 kg	3000	75 g	1125 kg	1500 kg
350 1000 kg	1000 kg	3000	100 g	1500 kg	2000 kg
350 1500 kg	1500 kg	3000	150 g	2250 kg	3000 kg
350 2000 kg	2000 kg	3000	200 g	3000 kg	4000 kg

MODELO 350 T (300...2000 kg)

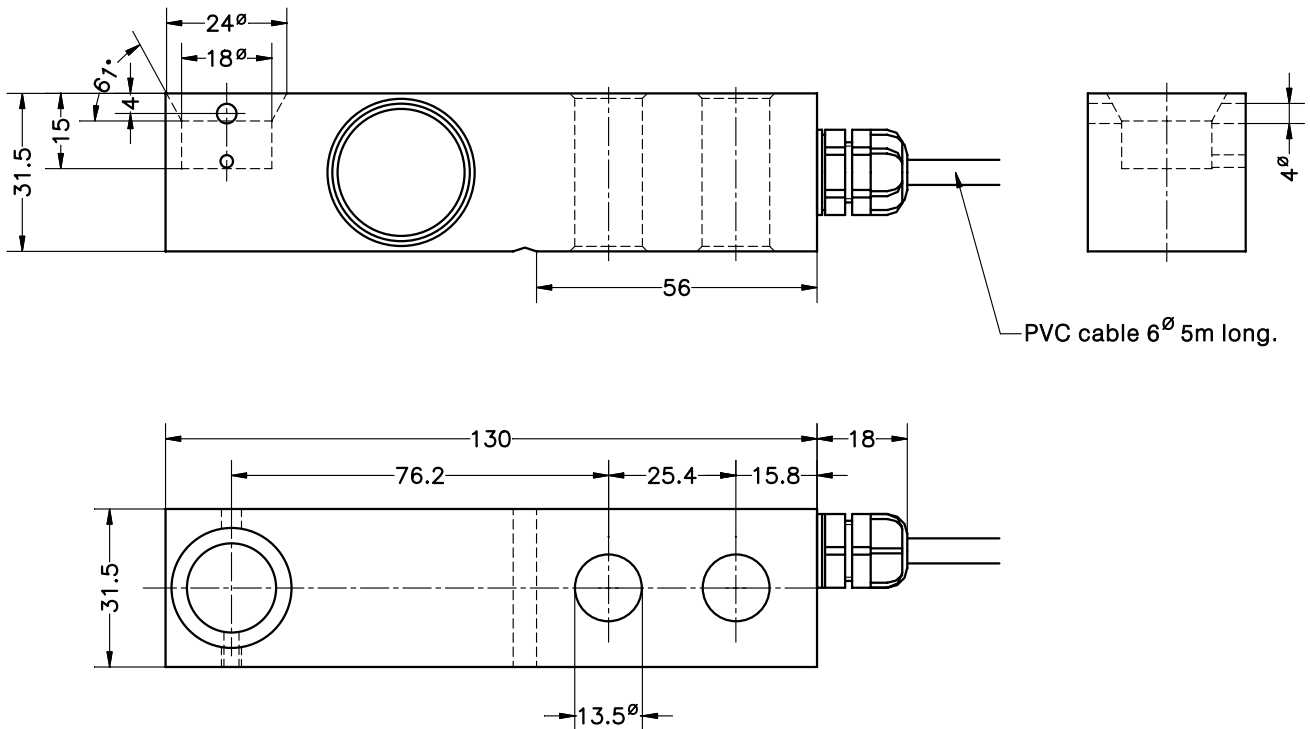

Dimensiones en mm. *Dimensions in mm.*

Peso transporte - *Transport weight:* 0.9 kg

ESPECIFICACIONES			SPECIFICATIONS
Cargas nominales (Ln)	300-500-750-1000-1500-2000	kg	Nominal capacities (Ln)
Clase de precisión	3000	n. OIML	Accuracy class
Carga mínima	0	%Ln	Minimum dead load
Carga de servicio	150	%Ln	Service load
Cargas límite	200	%Ln	Safe load limit
Error combinado	< ±0.017	%Sn (1)	Total error
Error repetibilidad	< ±0.015	%Sn	Repeatability error
Efecto de la temperatura: en el cero	< ±0.01	%Sn/5 °C	Temperature effect: on zero
en la sensibilidad	< ±0.006	%Sn/5 °C	on sensitivity
Error de fluencia (30 minutos)	< ±0.016	%Sn	Creep error (30 minutes)
Compensación de temperatura	-10...+40	°C	Temperature compensation
Límites de temperatura	-30...+70	°C	Temperature limits
Sensibilidad nominal (Sn)	2	mV/V (2)	Nominal sensitivity (Sn)
Tensión de alimentación nominal	10	V	Nominal input voltage
Tensión de alimentación máxima	15	V	Maximum input voltage
Resistencia de entrada	400 ±20	Ω	Input impedance
Resistencia de salida	350 ±3	Ω	Output impedance
Desequilibrio inicial	< ±2	%Sn	No load output
Resistencia de aislamiento	> 5000	MΩ	Insulation resistance
Deformación máxima (a Ln)	0.2-0.4	mm	Maximum deflection (at Ln)

CONEXIÓN ELÉCTRICA
ELECTRICAL CONNECTION:

MOD. 350 Ta

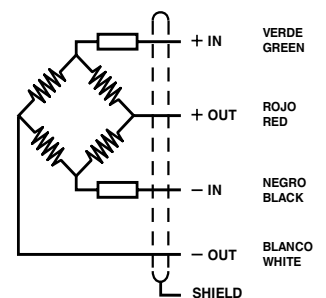

MOD. 350 Ti

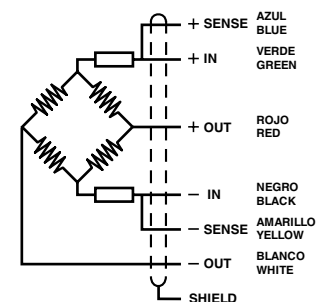

(1) Error combinado: No Linealidad e Histéresis / Total error: Non Linearity and Hysteresis

(2) Preajuste de esquinas optimizado al ±0.05% mediante la calibración de la corriente de salida / Pre-corner adjustment optimized at ±0.05% by output current calibration

ACCESORIO PIE AUTOCENTRANTE PARA MOD. 350 T
LOAD FOOT ACCESSORY FOR MODEL 350 T

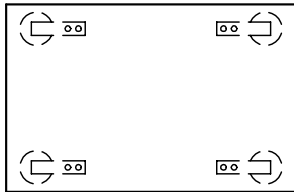

Mod. **350**

+

Acc. **35916i**

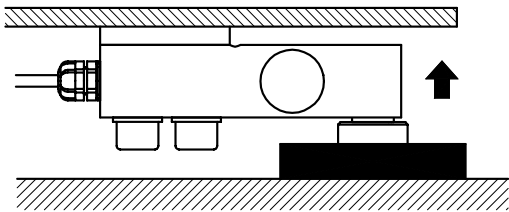

- **Materiales: acero inoxidable y goma**
- **Materials: Stainless Steel and Rubber**

Acc. 35916i para Mod. 350 opción T (300...2000 kg) / For Model 350 option T (300...2000 kg)

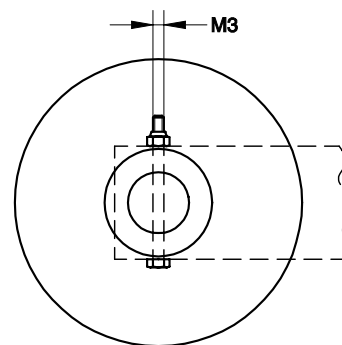
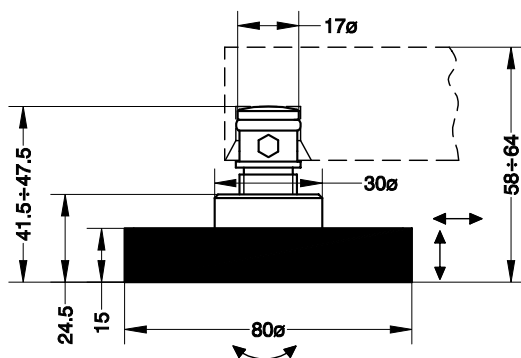

Dimensiones en mm. *Dimensions in mm.*

Peso transporte - *Transport weight:* 0.3 kg