NEGRI BOSSI



Presse a iniezione di manifattura italiana dal 1947: design e passione i nostri tratti distintivi

Negri Bossi offre una gamma completa di prodotti da 70 a 7000 tons. Con un'amplia scelta di macchine (idraulica, ibrida per poi arrivare al full electric) e grazie a tecnologie dei processi riusciamo a garantire ottime soluzioni alle vostre richieste.

Injection moulding machinery made in Italy since 1947: passion and design are our distinguishing features

Negri Bossi offers a complete range of products from 70 to 7000 ton for all market sectors. With a comprehensive choice of drive systems, from hydraulic to Hybrid and full electric, and process technologies you can be assured of the optimum solution for your requirements.

Máquinas de inyección de plástico fabricadas en Italia desde 1947: El diseño y la pasión nos distinguen

Negri Bossi ofrece una completa gama de productos desde las 70 hasta las 7000 Toneladas de fuerza de cierre para todos los sectores. Con una amplia variedad de soluciones, desde máquinas totalmente hidráulicas, híbridas o eléctricas y aplicaciones tecnológicas para los procesos, pudiendo así obtener la solución óptima para cada aplicación.

Presses à injection made in Italy depuis 1947: passion et design sont notre sont nos signes distinctifs

NEGRI BOSSI propose une gamme complète de produits de 70 à 7000 tonnes pour tous les secteurs du marché. Avec un choix pléthorique de systèmes d'entraînement (de l'hydraulique à l'électrique en passant par l'hybride) et de procédés technologiques, vous êtes assurés de trouver la solution optimale pour répondre à vos exigences.

EOS

ton.	70	110	180							
------	----	-----	-----	--	--	--	--	--	--	--

ELEOS

ton.	80	120								
------	----	-----	--	--	--	--	--	--	--	--

eVESTA

ton.	80	130	170	220	300	400				
------	----	-----	-----	-----	-----	-----	--	--	--	--

eCANBIO

ton.	90	130	180	250	330	400	500			
------	----	-----	-----	-----	-----	-----	-----	--	--	--

eCANBIMAT

ton.	90	130	180	250	330	400	500	650	800	
------	----	-----	-----	-----	-----	-----	-----	-----	-----	--

GLOBAL

ton.	130	180	250	330	430					
------	-----	-----	-----	-----	-----	--	--	--	--	--

eJANUS

ton.	200	300	360	450	580	720				
------	-----	-----	-----	-----	-----	-----	--	--	--	--

eVECTOR

ton.	650	800	1100/1100WP	1300						
------	-----	-----	-------------	------	--	--	--	--	--	--

BI-POWER

ton.	1000	1300	1500	2000	2500	2700	3500	4200	5500	7000
------	------	------	------	------	------	------	------	------	------	------

Speed

Product by Sector

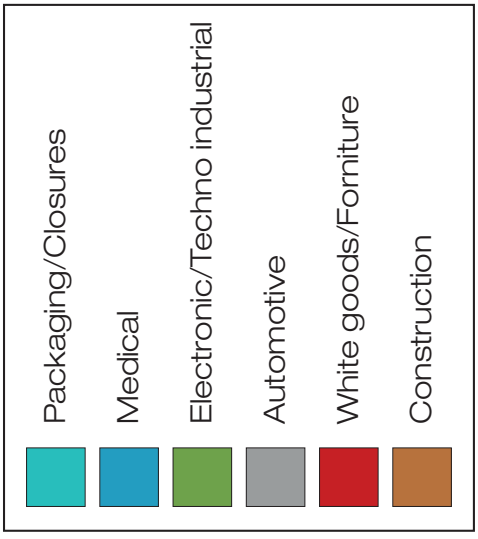
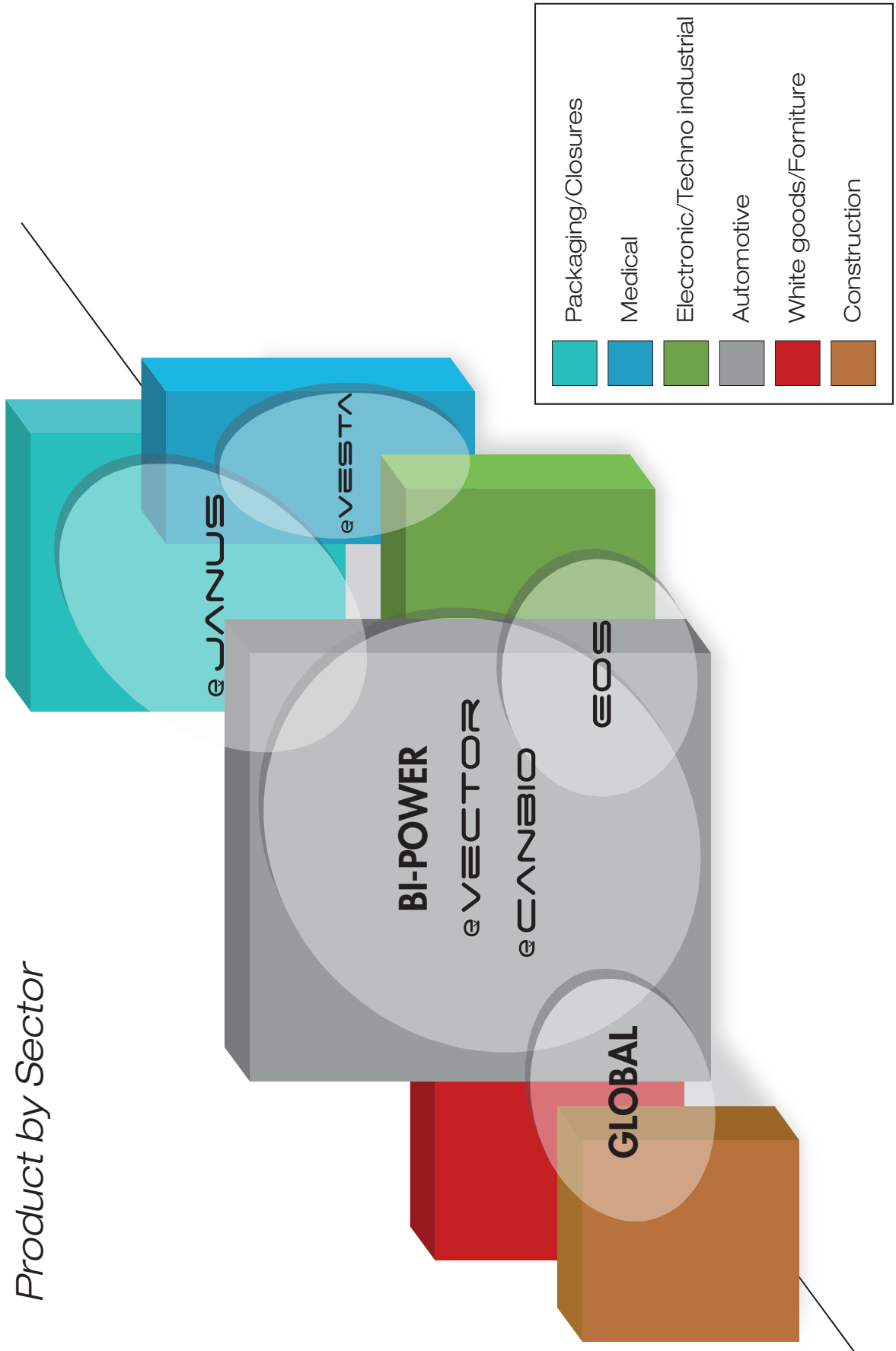

Performance



INJECTION MOLDING MACHINES FOR EVERY NEEDS

Negri Bossi is able to offer material specific machinery with dedicated screw profiles & plasticising units for processing all materials and applications Including LSR, Thermoset, PVC, Barrier screws.

Technologies/Applications:

Gas-water Injection, MuCell, Heat&Cool, IML, Foaming, Micromoulding

TCS

Thermo-regulated core system

Negri Bossi has developed thermo-regulated screws with a profile capable of ensuring more than 4000 grams of injection capacity

Viti specifiche per termoindurente

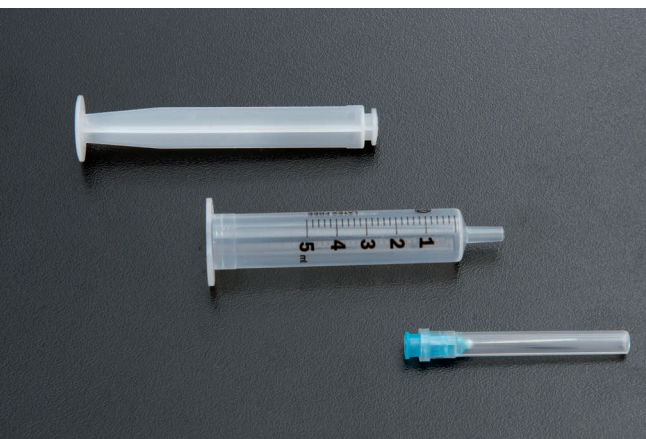
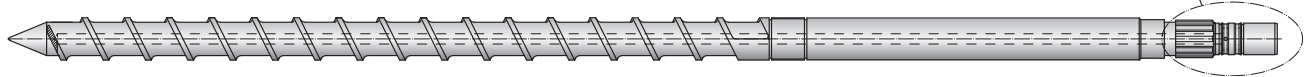
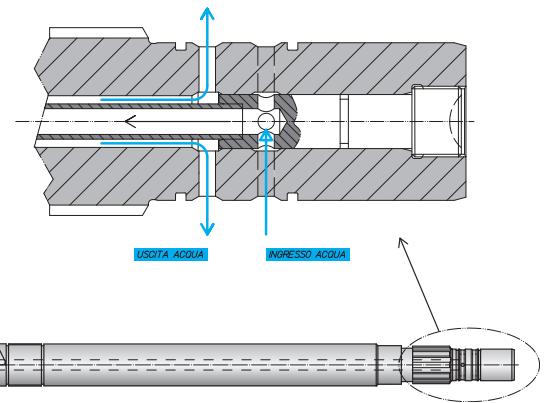

MEDICAL

Several solutions for medical requires. Clean Moulding Zone and hydraulic controls guarantee reliability and precision of products.

Massima cura e pulizia nella zona stampaggio. Controlli termici ed idraulici garantiscono precisione e ripetibilità.

Micromoulding

Micromoulding Solutions

shot weight (plastic part+sprue): 0,48g

Microstampaggio

peso stampata (pezzo+materozza): 0,48g

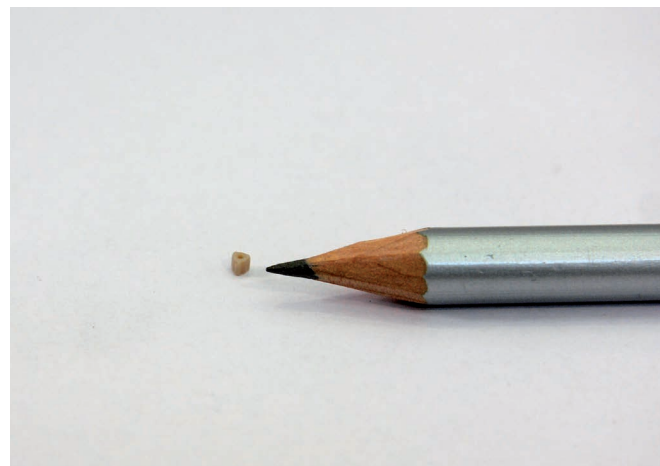

MACCHINE DEDICATE PER OGNI ESIGENZA

Negri Bossi offre macchine personalizzate con viti speciali, unità di plastificazioni per ogni tipo di materiale plastico e applicazioni come: LSR, termoindurente, PVC e viti Barriera.

ding

Iniezione assistita

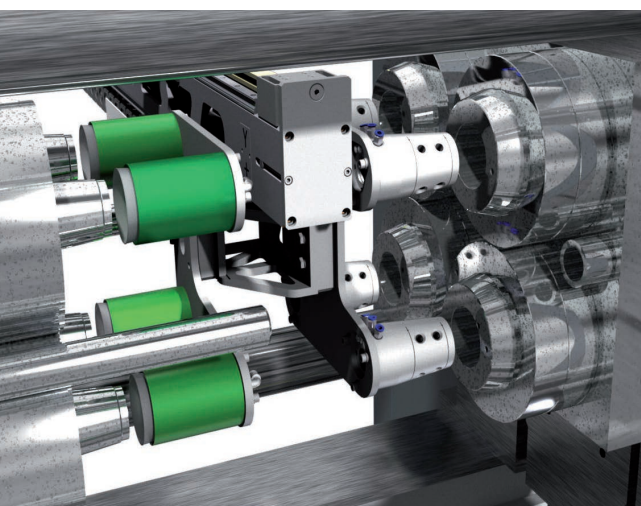

IML

Inside Moulding

Labelling-Insert Moulding

Several solutions for integrated automation

Differenti soluzioni per automazioni integrate

Heat & Cool

Thermic System that optimizes flow in the cavities; it guarantees clarity and transparency on materials like PC ABS and PMMA.

Sistema termico che ottimizza il flusso nelle cavità garantendo trasparenza e lucentezza delle superfici di materiali come PC,ABS e PMMA



Conventional Moulding

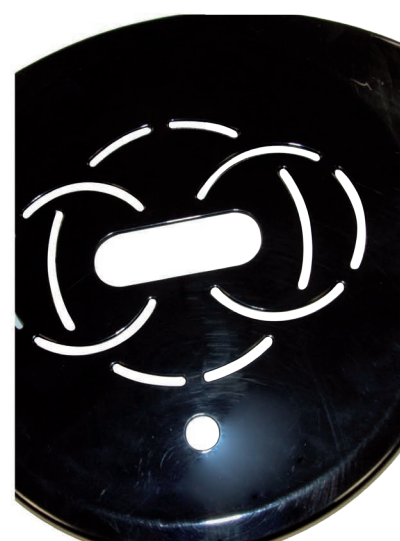

Heat & Cool Moulding

AMICO Supervision SOFTWARE

- *Plant-wide Machine Status*
- *Production Control Information*
- *Machine Alarms Tracking*
- *Full Part Trace / Process Trending*
- *SPC Data / Cycle to Cycle*
- *Machine Efficiency Data*

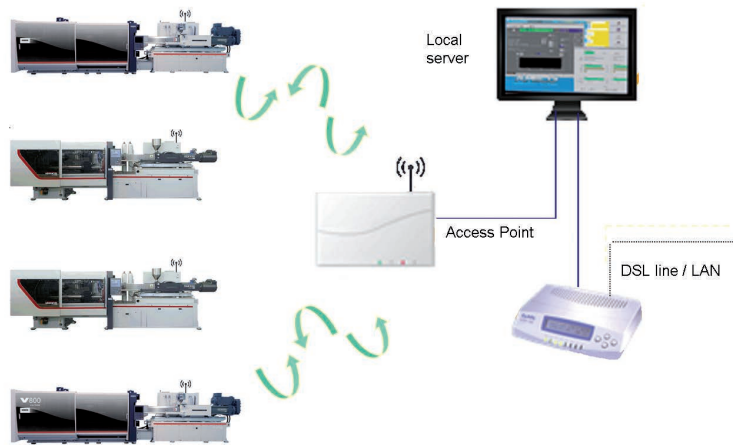

Tecnologie e Applicazioni:
con Gas-Acqua, Mucell, Heat&cool, IML, Foaming, Microstampaggio

WIT

Water Injection Technology
Available also with GAS
Stampaggio ad iniezione con acqua
Disponibile anche con GAS



MProcesses
uCell
TREXEL INC.

Mucell Technology

Mucell Microcellular Foaming Technology provides unique design flexibility and cost savings opportunities
Garantisce flessibilità, riduzione peso, resistenza strutturale

FOAMING

The process foresees a physical expansion of the plastic material which allows the manufacturing of lighter parts with better technical specifications and no signs of eddies.
Aspetto estetico e leggerezza sono i punti di forza di questa applicazione.



NEGRI BOSSI



www.negribossi.com