



System Components for Automation

Catalog

14



Have you seen our new TB20 catalog?

The new **TB20** distributed fieldbus I/O system by Systeme Helmholz was shaped by direct feedback from our customers, and as a result integrates a wide variety of detailed features designed for the challenges of real-life applications. Efficiency, functionality, and ideal ergonomics were all at the center during the development process. The result? The innovative system makes it surprisingly easy to use the distinctive strengths of distributed system designs in countless applications.

With the TB20 system, Helmholz has added technologically standardized solutions for distributed applications to its portfolio. Bus couplers for PROFIBUS, PROFINET and CANopen® with analog and digital inputs and outputs make up the starting range of products in the family, and we will continue to gradually expand it in order to incorporate all conventional fieldbuses and ensure that TB20 remains an open-ended system.

Systeme Helmholz GmbH's catalogs are available for download at www.helmholz.com, or ask your local Helmholz contact for print version.



How to contact us

Orders by phone: +49 9135 7380-0
 Orders by fax: +49 9135 7380-490
 Orders by email: orders@helmholz.de

On the Internet

Homepage: www.helmholz.com
 Email: info@helmholz.de



Don't miss any important information!

Sign up now for our newsletter „Automation Update“! You'll receive new information on our products, trade shows, workshops and important messages on product modifications comfortably by email.

www.helmholz.com





PROFIBUS

Page

7–38



NETLink® Gateways

39–48



Teleservice

49–60



Components for S7

61–92



CAN Bus

93–101



Interface Converter

102–109



Service

110–115

Systeme Helmholz®, **EasyConnect**®, **FLEXtra**® and **NETLink**® are registered trademarks of Systeme Helmholz GmbH. S7-200, S7-300, S7-400, WinCC, ProTool, Simatic and STEP are registered trademarks of Siemens AG. All companies and product names mentioned are only used for identification purposes and are/can be registered trademarks of the respective brand owner.

Our General Terms and Conditions of business are applicable. For all information in this catalogue, particularly for the stated technical values, dimensions and weights, we reserve the right to make changes and accept no responsibility for errors and omissions. Illustrations can be different from the original.
Date November 2012

PROFIBUS**PROFIBUS Connectors**

PROFIBUS Connector Overview	8
PROFIBUS Connector, 90°	9
PROFIBUS Connector, 35°	10
PROFIBUS Connector, axial cable outlet	11
PROFIBUS Connector, 90° EasyConnect ®	12
PROFIBUS Connector, angled EasyConnect ®	13
PROFIBUS Connector, axial EasyConnect ®	14
PROFIBUS Connector, 90° with diagnostic LEDs, EasyConnect ®	15
PROFIBUS Connector, angled with diagnostic LEDs, EasyConnect ®	16
PROFIBUS Connector, 90° with diagnostic LEDs	17
PROFIBUS Connector 90° M12; PROFIBUS Connector 90° M12 with diagnostic LEDs	18
PROFIBUS Connector, 90° with ATEX accreditation	19

PROFIBUS Repeater

FLEXtra® twinRepeater, PROFIBUS Repeater	20
FLEXtra® multiRepeater 4-way/6-way, PROFIBUS Repeater	22
PROFIBUS Compact Repeater	24

PROFIBUS FO

OPTopus, PROFIBUS Optical Link	26
FLEXtra® FO, PROFIBUS Optical Hub	28

PROFIBUS Radio System

viBlu, PROFIBUS Radio System	30
PAS 153 viBlu, distributed PROFIBUS Radio Interface	32
Antennas for NETLink® WLAN and viBlu	34

PROFIBUS Communication

PAS 153, distributed PROFIBUS Interface	35
DP/DP Coupler	36

PROFIBUS Accessory

FLEXtra® profiPoint, active Termination and Measuring Point	37
Active PROFIBUS Dropcable	38
PROFIBUS cable assembled	38

NETLink® Gateways**Ethernet**

NETLink® PRO Compact, PROFIBUS Ethernet Gateway	40
NETLink® PRO PoE, PROFIBUS Ethernet Gateway	42
NETLink® Switch, Ethernet Gateway with integrated 4-port Switch	43

WLAN

NETLink® WLAN, PROFIBUS Ethernet WLAN Gateway	44
Antennas for NETLink® WLAN and viBlu	45

NETLink® PRO Family applications

NETLink® PRO Family applications	46
--	----

USB

NETLink® USB Compact, mini PROFIBUS USB Gateway	47
---	----

OPC

OPC-Server	48
------------------	----

Teleservice

Router

REX 300, Ethernet Router	50
--------------------------------	----

SSW7/TS 300

SSW7-TS, MPI Adapter	55
SSW7-TS with Modem; analog/ISDN/GSM	56
SSW7-TS PRO analog/ISDN/GSM	57
TS 300, Teleservicemodule for the S7 Rack	58

Antennas

Antennas for GSM Modems	60
-------------------------------	----

Components for S7

Memory for S7

Micro Memory Cards	62
Memory Cards	63

Input/Output Modules for S7

DEA 300, Digital Input Modules	64
DEA 300, Digital Input Module, m-reading	66
DEA 300, Digital Output Modules	67
DEA 300, Digital Input/Output Modules	69
DEA 300, Digital Output Module; 2 Amps	71
DEA 300, Digital Output; Relays	72
DEA 300, Digital Output; Relays Bistable	74
DEA 300, Digital Input Modules; 120/230 V	75
AEA 300, Analog Input Module for Connecting Sensors with Current Signals	76
AEA 300, Analog Input Module for Connecting Sensors with Voltage Signals	77
AEA 300, Analog Input Module for Connecting Resistance Thermometers	78
AEA 300, Analog Input Module; Current Signals, Voltage Signals, Resistance, Resistance Thermometer	79
AEA 300, Analog Output Module; 4-Channel	80
AEA 300, Analog Output Modules; 2-Channel	81
Dummymodule	82
PAS 153, distributed PROFIBUS Interface	83

Communication Modules

SAS 340, Communication Module	84
SAS 341, Communication Module	85
SAS 341-1, with Modbus RTU Driver	86
EIB 300, Communication Module for Twisted Pair EIB/KNX	87

Front Connectors for S7

FastPlug , Frontadapter for S7 modules	89
Front Connectors with screw contacts, Front Connectors EasyConnect [®]	90
Front Connectors with spring contacts, Ready-wired Front Connectors	91

Accessory

Mounting rail, Mounting rail adapter for DIN rail	92
---	----

CAN Bus

Communication Modules

CAN 300 PRO, Communication Module	94
CAN 400, Communication Module	96

Software

CAN Software	97
--------------------	----

Coupler

DP/CAN Coupler CANopen® 98

DP/CAN Coupler Layer 2 99

Accessory/Connectors

CAN Bus Connector 100

CAN Bridge

CAN Bridge, connecting CAN networks 101

Interface Converters**MPI-Bus**

SSW7, MPI-Programming Adapter 103

SSW7-USB, MPI-Programming Adapter USB 104

SSW7-RK512, SSW7-HMI, MPI-Adapter with RK512/HMI Protocol 105

S5 Interface Converters

SSW5/LAN, S5 Ethernet Converter 107

SSW5/USB, Programming Cable 108

SSW3 Converter Cable 109

Service

Training Courses, PROFIBUS Service 111

REX Workshop 112

Contacts in Germany 114





































International Contacts 115



PROFIBUS (www.profibusstecker.de)

PROFIBUS Connectors
Repeater
PROFIBUS FO
Radio System
Communication

PROFIBUS Connector Overview

Connection type	Cable type	Direction	Product Image	without PG	with PG	Page
Screw terminals		90°		700-972-0BA12 	700-972-0BB12 	9
		90° with Diagnostic		700-972-7BA12 	700-972-7BB12 	17
		35°		700-972-0BA41 	700-972-0BB41 	10
		axial		700-972-0CA12 		11
		90° with ATEX accreditation		700-973-0BA12 	700-973-0BB12 	19
EasyConnect®	solid	90°		700-972-0BA50 	700-972-0BB50 	12
		90° with Diagnostic		700-972-7BA50 	700-972-7BB50 	15
		angled		700-972-0BA51 	700-972-0BB51 	13
		angled with Diagnostic			700-972-7BB51	16
		axial		700-972-0CA50 		14
	flexible	90°		700-972-0FA50 	700-972-0FB50 	12
		90° with Diagnostic		700-972-7FA50 	700-972-7FB50 	15
		angled		700-972-0FA51 	700-972-0FB51 	13
		axial		700-972-0CF50 		14
		M12		90°		700-974-0BA12 
90° with Diagnostic					700-974-7BB12	18

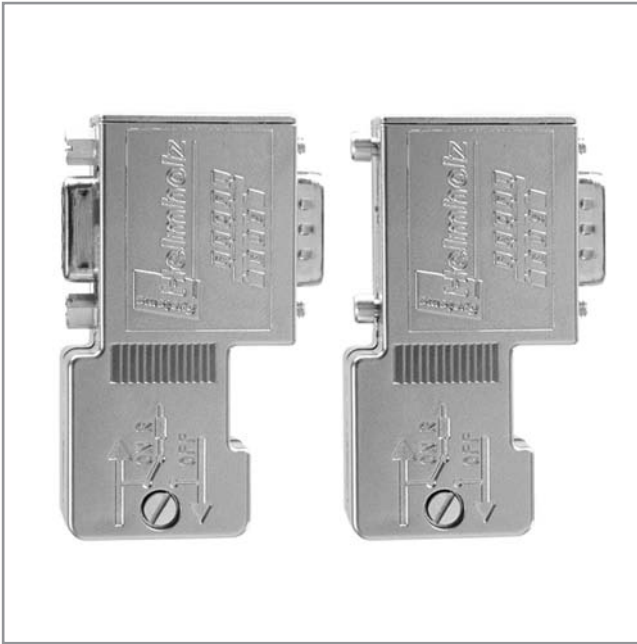

PROFIBUS connector 90° with (l.) and without (r.) programming device connector

The PROFIBUS connector 90° is equipped with proven and reliable screw terminals.
 The connector is quickly mounted and has integrated, connectable terminating resistors.
 The housing is metallized for improved electromagnetic compatibility.

Features

- Metalized housing
- No loosable parts
- Integrated switchable terminating resistor
- 90° cable outlet
- Screw terminals

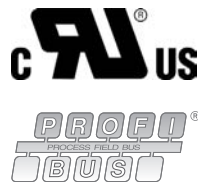

Ordering Data	Order No.
PROFIBUS Connector, 90° without prog. device connector with prog. device connector 90°	700-972-0BA12 700-972-0BB12
Stripping tool for PROFIBUS	700-972-6AA00

The PROFIBUS connectors are also available in boxes containing 10 or 50 pieces.
 1) FastConnect is a registered trademark of Siemens AG.

Technical Data	
Programming device connector Order No. 700-972-0BB12 Order No. 700-972-0BA12	Yes No
Dimensions (D x W x H mm)	64 x 40 x 17
Weight	Approx. 40 g
Outgoing cable	Vertical outgoing cable suitable for FastConnect ¹⁾ stripping tool
Terminating resistor	Resistor combination integrated and connectable with slide switch
Transmission rate max.	12 Mbps
Interfaces PROFIBUS station	SUB-D, 9-way
Max. outside diameter	8.0 mm
PROFIBUS cable	60/75 °C copper wire up to 1.0 mm ²
Connection type	4 terminals
Voltage consumption	4.75 ... 5.25 V DC (must come from connected equip)
Current consumption max.	12.5 mA
Environmental pollution degree	2
Ambient temperature Transport and storage temperature	0 °C ... +60 °C -25 °C ... +80 °C
Relative humidity max.	75% at +25 °C
Degree of protection	IP 20

PROFIBUS Connector, 35°



PROFIBUS connector 35° with (l.) and without (r.) programming device connector

The PROFIBUS connector 35° is equipped with proven and reliable screw terminals. The connector is quickly mounted and has integrated, connectable terminating resistors. The housing is metallized for improved electromagnetic compatibility.

Features

- Metalized housing
- No loosable parts
- Integrated switchable terminating resistor
- 35° cable outlet
- Screw terminals



Ordering Data	Order No.
PROFIBUS Connector, 35° without prog. device connector	700-972-0BA41
with prog. device connector	700-972-0BB41

The PROFIBUS connectors are also available in boxes containing 10 or 50 pieces.

Technical Data	
Programming device connector Order No. 700-972-0BB41 Order No. 700-972-0BA41	Yes No
Dimensions (D x W x H mm)	54 x 40 x 17
Weight	Approx. 40 g
Outgoing cable	35° outgoing cable
Terminating resistor	Resistor combination integrated and connectable with slide switch
Transmission rate	max. 12 Mbps
Interfaces PROFIBUS station	SUB-D, 9-way
Max. outside diameter	8.0 mm
PROFIBUS cable	60/75 °C copper wire up to 1.0 mm ²
Connection type	4 terminals
Voltage consumption	4.75 ... 5.25 V DC (must come from connected equip)
Current consumption	max. 12.5 mA
Environmental pollution degree	2
Ambient temperature Transport and storage temperature	0 °C ... +60 °C -25 °C ... +80 °C
Relative humidity	max. 75 % at +25 °C
Degree of protection	IP 20



PROFIBUS connector, with axial cable outlet

Features

- Metalized housing
- No loosable parts
- Integrated switchable terminating resistor
- Axial cable outlet
- Screw terminals



The PROFIBUS connector with axial cable outlet is equipped with proven and reliable screw terminals. The connector is quickly mounted and has integrated, connectable terminating resistors. The housing is metallized for improved electromagnetic compatibility.

Technical Data	
Dimensions (D x W x H mm)	68 x 39.5 x 17
Weight	Approx. 40 g
Outgoing cable, axial	Axial outgoing cable, suitable for FastConnect ¹⁾ stripping tool
Terminating resistor	Resistor combination integrated and connectable with slide switch
Transmission rate	max. 12 Mbps
Interfaces	
PROFIBUS station	SUB-D, 9-way
Max. outside diameter	8.0 mm
PROFIBUS cable	60/75 °C copper wire up to 1.0 mm ²
Connection type	4 terminals
Voltage consumption	4.75 ... 5.25 V DC (must come from connected equip)
Current consumption	max. 12.5 mA
Environmental pollution degree	2
Ambient temperature	0 °C ... +60 °C
Transport and storage temperature	-25 °C ... +80 °C
Relative humidity	max. 75% at +25 °C
Degree of protection	IP 20

Ordering Data	Order No.
PROFIBUS Connector, axial axial cable outlet	700-972-0CA12

The PROFIBUS connectors are also available in boxes containing 10 or 50 pieces
 1) FastConnect is a registered trademark of Siemens AG.

PROFIBUS Connector, 90° **EasyConnect**[®]



PROFIBUS connector, 90° **EasyConnect**[®]

The PROFIBUS connector 90° **EasyConnect**[®] features quick-connect technology, which makes stripping the bus wires superfluous. Once the cable has been installed it is easy to check (visual inspection) that the PROFIBUS cable has been correctly connected. The housing is metallized for improved electromagnetic compatibility.

The **EasyConnect**[®] connector also works in the extended ambient temperature range of -25 °C to +70 °C.

Features

- Metalized housing
- No loosable parts
- Integrated switchable terminating resistor
- 90° cable outlet
- **EasyConnect**[®] technology
- Visual connection control



Ordering Data	Order No.
PROFIBUS Connector, 90° EasyConnect[®] for solid cables	
without prog. device connector	700-972-0BA50
with prog. device connector	700-972-0BB50
PROFIBUS Connector, 90° EasyConnect[®] for flexible cables	
without progr. device connector 90°	700-972-0FA50
with progr. device connector 90°	700-972-0FB50
Stripping tool for PROFIBUS	700-972-6AA00

Technical Data	
Programming device connector	
Order No. 700-972-0BB50/-0FB50	Yes
Order No. 700-972-0BA50/-0FA50	No
Dimensions (D x W x H mm)	72 x 40 x 17
Weight	Approx. 40 g
Outgoing cable	Vertical outgoing cable suitable for FastConnect ¹⁾ stripping tool
Terminating resistor	Resistor combination integrated and connectable with slide switch
Transmission rate	max. 12 Mbps
Interfaces	
PROFIBUS station	SUB-D, 9-way
Max. outside diameter	8.0 mm
PROFIBUS cable	FC standard cable solid or flexible; 0.64 mm Ø 60/75 °C copper wire
Connection type	EasyConnect[®]
Voltage consumption	4.75 ... 5.25 V DC (must come from connected equip)
Current consumption	max. 12.5 mA
Environmental pollution degree	2
Ambient temperature	-25 °C ... +70 °C
Transport and storage temperature	-25 °C ... +80 °C
Relative humidity	max. 75% at +25 °C
Degree of protection	IP 20

1) FastConnect is a registered trademark of Siemens AG.



PROFIBUS connector, angled **EasyConnect**[®]

Features

- Metalized housing
- No loosable parts
- Integrated switchable terminating resistor
- Angled cable outlet
- **EasyConnect**[®] technology
- Visual connection control

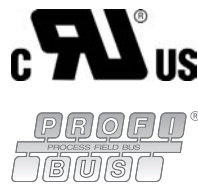

The PROFIBUS connector angled **EasyConnect**[®] features quick-connect technology, which makes stripping the bus wires superfluous. Once the cable has been installed it is easy to check (visual inspection) that the PROFIBUS cable has been correctly connected.

The housing is metallized for improved electromagnetic compatibility.

Technical Data	
Programming device connector Order No. 700-972-0BB51/-0FB51 Order No. 700-972-0BA51/-0FA51	Yes No
Dimensions (D x W x H mm)	95 x 70 x 17
Weight	Approx. 50 g
Outgoing cable	Angled outgoing cable
Terminating resistor	Resistor combination integrated and connectable with slide switch
Transmission rate max.	12 Mbps
Interfaces PROFIBUS station	SUB-D, 9-way
Max. outside diameter	8.0 mm
PROFIBUS cable	FC standard cable solid or flexible; 0.64 mm Ø 60/75 °C copper wire
Connection type	EasyConnect [®]
Voltage consumption	4.75 ... 5.25 V DC (must come from connected equip)
Current consumption max.	12.5 mA
Environmental pollution degree	2
Ambient temperature	0 °C ... +60 °C
Transport and storage temperature	-25 °C ... +80 °C
Relative humidity max.	75 % at +25 °C
Degree of protection	IP 20

Ordering Data	Order No.
PROFIBUS Connector, angled EasyConnect[®] for solid cables without prog. device connector with prog. device connector	700-972-0BA51 700-972-0BB51
PROFIBUS Connector, angled EasyConnect[®] for flexible cables without prog. device connector with prog. device connector	700-972-0FA51 700-972-0FB51

PROFIBUS Connector, axial **EasyConnect**[®]



PROFIBUS connector, axial **EasyConnect**[®]

Features

- Metalized housing
- No loosable parts
- Integrated switchable terminating resistor
- Axial cable outlet
- **EasyConnect**[®] technology
- Visual connection control



The PROFIBUS connector axial **EasyConnect**[®] features quick-connect technology, which makes stripping the bus wires superfluous. Once the cable has been installed it is easy to check (visual inspection) that the PROFIBUS cable has been correctly connected.

The housing is metallized for improved electromagnetic compatibility.

The **EasyConnect**[®] connector also works in the extended ambient temperature range of -25 °C to +70 °C.

Technical Data	
Dimensions (D x W x H mm)	70 x 35 x 17
Weight	Approx. 50 g
Outgoing cable	Vertical outgoing cable suitable for FastConnect ¹⁾ stripping tool
Terminating resistor	Resistor combination integrated and connectable with slide switch
Transmission rate	max. 12 Mbps
Interfaces	
PROFIBUS station	SUB-D, 9-way
Max. outside diameter	8.0 mm
PROFIBUS cable	FC standard cable solid or flexible; 0.64 mm Ø 60/75 °C copper wire
Connection type	EasyConnect [®]
Voltage consumption	4.75 ... 5.25 V DC (must come from connected equip)
Current consumption	max. 12.5 mA
Environmental pollution degree	2
Ambient temperature	0 °C ... +70 °C
Transport and storage temperature	-25 °C ... +80 °C
Relative humidity	max. 75% at +25 °C
Degree of protection	IP 20

Ordering Data	Order No.
PROFIBUS Connector, axial EasyConnect [®]	
for solid cables	700-972-0CA50
for flexible cables	700-972-0CF50

1) FastConnect is a registered trademark of Siemens AG.



PROFIBUS Connector, 90° with diagnostic LEDs, **EasyConnect®**

Features

- 3 status LEDs indicate “bus operation”, “station transmitting”, “terminating resistor inserted”
- Metalized housing
- No loosable parts
- Integrated switchable terminating resistor
- 90° cable outlet
- **EasyConnect®** technology
- Visual connection control



The PROFIBUS connector 90° with diagnostic LEDs **EasyConnect®** features quick-connect technology, which makes stripping the bus wires superfluous. Once the cable has been installed it is easy to check (visual inspection) that the PROFIBUS cable has been correctly connected.

The housing is metallized for improved electromagnetic compatibility.

The PROFIBUS diagnostic connector can be used to connect a PROFIBUS network in which the user can check the status of the bus system at any time at a glance.

The three built-in LEDs with the easily distinguished colors blue, green and orange indicate the most important states of the PROFIBUS network at each station.

The state of the terminating resistor (**orange**), whether bus activity is in progress (**green**) and whether the station addressed is participating in bus traffic (**blue**) are all indicated.

This means errors, such as bus interruptions, missing or incorrectly connected terminating resistors and malfunctioning or failed bus stations can be detected immediately.

Technical Data	
Programming device connector Order No. 700-972-7BB50/-7FB50 Order No. 700-972-7BA50/-7FA50	Yes No
Dimensions (D x W x H mm)	64 x 40 x 17
Weight	Approx. 40 g
Outgoing cable	Vertical outgoing cable suitable for FastConnect ¹⁾ stripping tool
Terminating resistor	Resistor combination integrated and connectable with slide switch
Transmission rate max.	12 Mbps
Interfaces	
PROFIBUS station	SUB-D, 9-way
Max. outside diameter	8.0 mm
PROFIBUS cable	FC standard cable solid, 0.64 mm Ø 60/75 °C copper wire
Connection type	EasyConnect®
Voltage consumption	4.75 ... 5.25 V DC (must come from connected equip)
Current consumption max.	35 mA
Environmental pollution degree	2
Ambient temperature	0 °C ... +60 °C
Transport and storage temperature	-25 °C ... +80 °C
Relative humidity max.	75% at +25 °C
Degree of protection	IP 20

Ordering Data	Order No.
PROFIBUS Connector, 90° with diagnostic LEDs EasyConnect® for solid cables without prog. device connector with prog. device connector	700-972-7BA50 700-972-7BB50
PROFIBUS Connector, 90° with diagnostic LEDs EasyConnect® for flexible cables without prog. device connector with prog. device connector	700-972-7FA50 700-972-7FB50
Stripping tool for PROFIBUS	700-972-6AA00

1) FastConnect is a registered trademark of Siemens AG.

PROFIBUS Connector, angled with diagnostic LEDs, **EasyConnect®**



PROFIBUS Connector, angled with diagnostic LEDs, **EasyConnect®**

Features

- 3 status LEDs indicate “bus operation”, “station transmitting”, “terminating resistor inserted”
- Metalized housing
- No loosable parts
- Integrated switchable terminating resistor
- angled cable outlet
- **EasyConnect®** technology
- Visual connection control



The PROFIBUS Connector angled with diagnostic LEDs **EasyConnect®** features quick-connect technology, which makes stripping the bus wires superfluous. Once the cable has been installed it is easy to check (visual inspection) that the PROFIBUS cable has been correctly connected.

The housing is metallized for improved electromagnetic compatibility.

The PROFIBUS diagnostic connector can be used to connect a PROFIBUS network in which the user can check the status of the bus system at any time at a glance.

The three built-in LEDs with the easily distinguished colors blue, green and orange indicate the most important states of the PROFIBUS network at each station.

The state of the terminating resistor (**orange**), whether bus activity is in progress (**green**) and whether the station addressed is participating in bus traffic (**blue**) are all indicated.

This means errors, such as bus interruptions, missing or incorrectly connected terminating resistors and malfunctioning or failed bus stations can be detected immediately.

Ordering Data	Order No.
PROFIBUS Connector, angled with diagnostic LEDs EasyConnect® for solid cables with prog. device connector	700-972-7BB51

Technical Data	
Programming device connector	Yes
Dimensions (D x W x H mm)	95 x 70 x 17
Weight	Approx. 50 g
Outgoing cable	Angled outgoing cable
Terminating resistor	Resistor combination integrated and connectable with slide switch
Transmission rate	max. 12 Mbps
Interfaces	
PROFIBUS station	SUB-D, 9-way
Max. outside diameter	8.0 mm
PROFIBUS cable	FC standard cable solid, 0.64 mm Ø 60/75 °C copper wire
Connection type	EasyConnect®
Voltage consumption	4.75 ... 5.25 V DC (must come from connected equip)
Current consumption	max. 35 mA
Environmental pollution degree	2
Ambient temperature	0 °C ... +60 °C
Transport and storage temperature	-25 °C ... +80 °C
Relative humidity	max. 75 % at +25 °C
Degree of protection	IP 20



PROFIBUS Connector, 90° with diagnostic LEDs

The PROFIBUS connector 90° with diagnostic LEDs is equipped with proven and reliable screw terminals. The connector is quickly mounted and has integrated, connectable terminating resistors. The housing is metallized for improved electromagnetic compatibility. The PROFIBUS diagnostic connector can be used to connect a PROFIBUS network in which the user can check the status of the bus system at any time at a glance. The three built-in LEDs with the easily distinguished colors blue, green and orange indicate the most important states of the PROFIBUS network at each station. The state of the terminating resistor (**orange**), whether bus activity is in progress (**green**) and whether the station addressed is participating in bus traffic (**blue**) are all indicated. This means errors, such as bus interruptions, missing or incorrectly connected terminating resistors and malfunctioning or failed bus stations can be detected immediately.

Features

- 3 status LEDs indicate “bus operation”, “station transmitting”, “terminating resistor inserted”
- Metalized housing
- No loosable parts
- Integrated switchable terminating resistor
- 90° cable outlet
- Screw terminals



Ordering Data	Order No.
PROFIBUS Connector, 90° with diagnostic LEDs	
without prog. device connector 90°	700-972-7BA12
with prog. device connector 90°	700-972-7BB12
Stripping tool for PROFIBUS	700-972-6AA00

1) FastConnect is a registered trademark of Siemens AG.

Technical Data	
Programming device connector	
Order No. 700-972-7BB12	Yes
Order No. 700-972-7BA12	No
Dimensions (D x W x H mm)	64 x 40 x 17
Weight	Approx. 40 g
Outgoing cable	Vertical outgoing cable suitable for Fast-Connect ¹⁾ stripping tool
Terminating resistor	Resistor combination integrated and connectable with slide switch
Transmission rate	max. 12 Mbps
Interfaces	
PROFIBUS station	SUB-D, 9-way
Max. outside diameter	8.0 mm
PROFIBUS cable	60/75 °C copper wire up to 1.0 mm ²
Connection type	4 terminals
Voltage consumption	4.75 ... 5.25 V DC (must come from connected equip)
Current consumption	max. 35 mA
Environmental pollution degree	2
Ambient temperature	0 °C ... +60 °C
Transport and storage temperature	-25 °C ... +80 °C
Relative humidity	max. 75% at +25 °C
Degree of protection	IP 20

PROFIBUS Connector 90° M12; PROFIBUS Connector 90° M12 with diagnostic LEDs



PROFIBUS Connector, 90° M12

The PROFIBUS connector M12 is used to connect PROFIBUS stations to a PROFIBUS cable with an M12 connection. The use of prefabricated system cables eliminates connection faults. Assembly effort is reduced to a minimum. The connector has two M12 connections and integrated terminating resistors. The housing is metal-coated for improved electromagnetic compatibility.

The version with diagnostic LEDs can be used to connect a PROFIBUS network in which the user can check the status of the bus system at any time at a glance. The three built-in LEDs with the easily distinguished colors blue, green and orange indicate the most important states of the PROFIBUS network at each station. The state of the terminating resistor (**orange**), whether bus activity is in progress (**green**) and whether the station addressed is participating in bus traffic (**blue**) are all indicated. This means errors, such as bus interruptions, missing or incorrectly connected terminating resistors and malfunctioning or failed bus stations can be detected immediately.



Order No. 700-974-0BA12 and 700-974-0BB12:



Ordering Data	Order No.
PROFIBUS Connector, 90° M12 without prog. device connector	700-974-0BA12
with prog. device connector	700-974-0BB12
PROFIBUS Connector, 90° M12 with diagnostic LEDs	700-974-7BB12
with prog. device connector	



PROFIBUS Connector, 90° M12 with diagnostic LEDs

Features

- Metalized housing
- No loosable parts
- Integrated switchable terminating resistor
- 90° cable outlet
- M12 connections

Technical Data		
Programming device connector		
Order No. 700-974-0BB12		Yes
Order No. 700-974-0BA12		No
Order No. 700-974-7BB12		Yes
Dimensions (D x W x H mm)		70 x 40 x 17
Weight		Approx. 60 g
Outgoing cable		Vertical outgoing cable
Terminating resistor		Resistor combination integrated and connectable with slide switch
Transmission rate	max.	12 Mbps
Interfaces		
PROFIBUS station		SUB-D, 9-way
Connection type		M12
Voltage consumption		4.75 ... 5.25 V DC (must come from connected equip)
Current consumption		
Order No. 700-974-0BB12	max.	12.5 mA
Order No. 700-974-0BA12	max.	12.5 mA
Order No. 700-974-7BB12	max.	35 mA
Environmental pollution degree		2
Ambient temperature		0 °C ... +60 °C
Transport and storage temperature		-25 °C ... +80 °C
Relative humidity	max.	75 % at +25 °C
Degree of protection		IP 20



PROFIBUS Connector, 90° with ATEX accreditation

Features

- Metalized housing
- No loosable parts
- Integrated switchable terminating resistor
- 90° cable outlet
- ATEX accreditation (II 3 G Ex nA II T4)
- Screw terminals



The PROFIBUS Connector 90° with ATEX accreditation is for usage in explosion hazardous areas of zone 2 (explosive gas atmosphere appears seldom and for very short time). The bus connector is plugged directly onto the PROFIBUS interface (SUB-D connector, 9-way) of the PROFIBUS stations. The PROFIBUS cables are connected using 4-way screw terminals. Using a slide switch you can set whether the connector is to be used as a node or segment end. The switch can also be operated when the connector is installed. The setting can be clearly seen. The connector is quickly mounted and has integrated, connectable terminating resistors.

Technical Data	
Programming device connector	Yes
Order No. 700-973-0BB12	No
Order No. 700-973-0BA12	
Dimensions (D x W x H mm)	64 x 40 x 17
Weight	Approx. 40 g
Outgoing cable	Vertical outgoing cable suitable for FastConnect ¹⁾ stripping tool
Terminating resistor	Resistor combination integrated and connectable with slide switch
Transmission rate max.	12 Mbps
Interfaces	
PROFIBUS station	SUB-D, 9-way
Max. outside diameter	8.0 mm
PROFIBUS cable	60/75 °C copper wire up to 1.0 mm ²
Connection type	4 terminals
Voltage consumption	4.75 ... 5.25 V DC (must come from connected equip)
Current consumption max.	12.5 mA
Environmental pollution degree	2
Ambient temperature	0 °C ... +60 °C
Transport and storage temperature	-25 °C ... +80 °C
Relative humidity max.	75% at +25 °C
Degree of protection	IP 20

Ordering Data	Order No.
PROFIBUS Connector with ATEX accreditation	
without prog. device connector, Ex-Zone 2	700-973-0BA12
with prog. device connector, Ex-Zone 2	700-973-0BB12
Stripping tool for PROFIBUS	700-972-6AA00

1) FastConnect is a registered trademark of Siemens AG.

FLEXtra® twinRepeater, PROFIBUS Repeater



FLEXtra® twinRepeater, PROFIBUS Repeater

Despite its compact size, the new FLEXtra® twinRepeater from Systeme Helmholz GmbH is a fully functioning PROFIBUS repeater. It is designed for mounting on a DIN rail. The FLEXtra® twinRepeater regenerates the electrical signal arriving on the bus line and retransmits it (bit reshaping and retransmission). The level, edge steepness, and mark-to-space ratio of the signals are reproduced exactly. It supports transmission rates from 9.6 kbps to 12 Mbps and automatically detects them. The twinRepeater offers an excellent method of extending the bus (up to 1 km with 2 FLEXtra® twinRepeaters), increasing the number of stations, and expanding the system. Moreover, it can be used in MPI networks. In particular, the FLEXtra® twinRepeater can be used to implement spur lines as independent segments. The status LEDs integrated for each segment provide a clear overview of the current bus status. What is more, the FLEXtra® twinRepeater electrically isolates the two PROFIBUS segments from each other. The twinRepeater also has a switch for deactivating the repeater function. This separates the segments, which nevertheless each remain able to function. PROFIBUS connectors are required for connection to the PROFIBUS cable (also available as a set).

Ordering Data	Order No.
FLEXtra® twinRepeater (incl. instruction)	700-972-2AA02
FLEXtra® twinRepeater Set FLEXtra® twinRepeater, 2 PROFIBUS Connectors screw terminals 90° with PG (incl. instruction)	700-972-2XA02

Features

- Can be used as bus extension or as a spur line
- Increases the number of stations on the bus
- System expansion
- Can also be used in MPI networks
- Status LEDs per segment
- Repeater function can be deactivated
- Electrical isolation



FLEXtra twinRepeater

Transmission Rate	max. segment length
9.6 kbps	1000 m
19.2 kbps	1000 m
45.45 kbps	1000 m
93.75 kbps	1000 m
187.5 kbps	1000 m
500 kbps	400 m
1.5 Mbps	200 m
3 Mbps	100 m
6 Mbps	100 m
12 Mbps	100 m

Technical Data	
Dimensions (D x W x H mm)	35 x 51 x 72
Weight	Approx. 110 g
Power supply	18 ... 30 VDC
Output voltage	5 V
Potential separation	500 V
Current consumption	max. 60 mA
Segment connection	Via PROFIBUS Connector
PROFIBUS interface	
Transmission rate	max. 12 Mbps autodetection
Protocol	PROFIBUS-DP to EN 61 158-2
Ambient temperature	0 °C ... +60 °C
Transport and storage temperature	-25 °C ... +75 °C
Degree of protection	IP 20

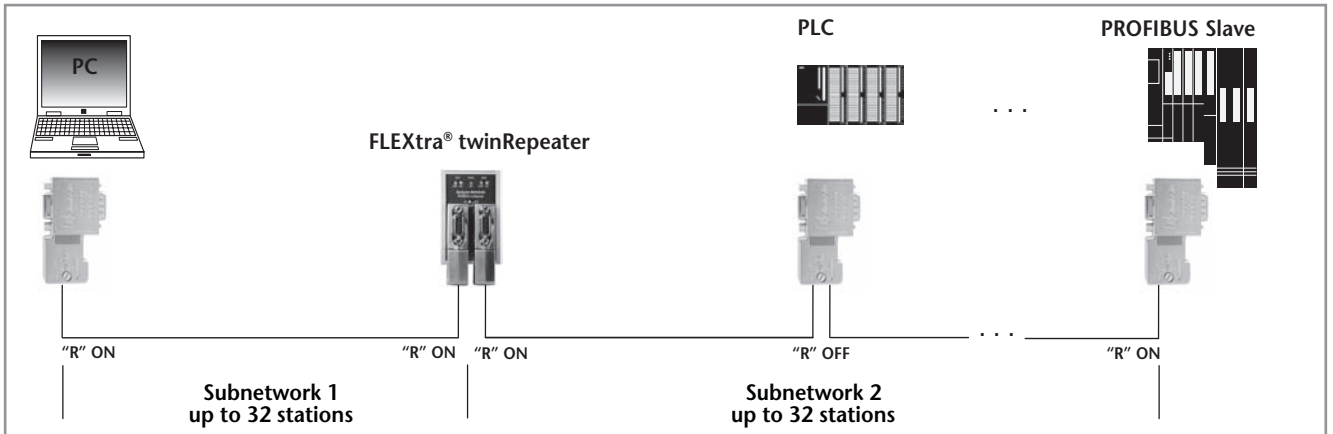

Application example FLEXtra® twinRepeater with more than 32 stations

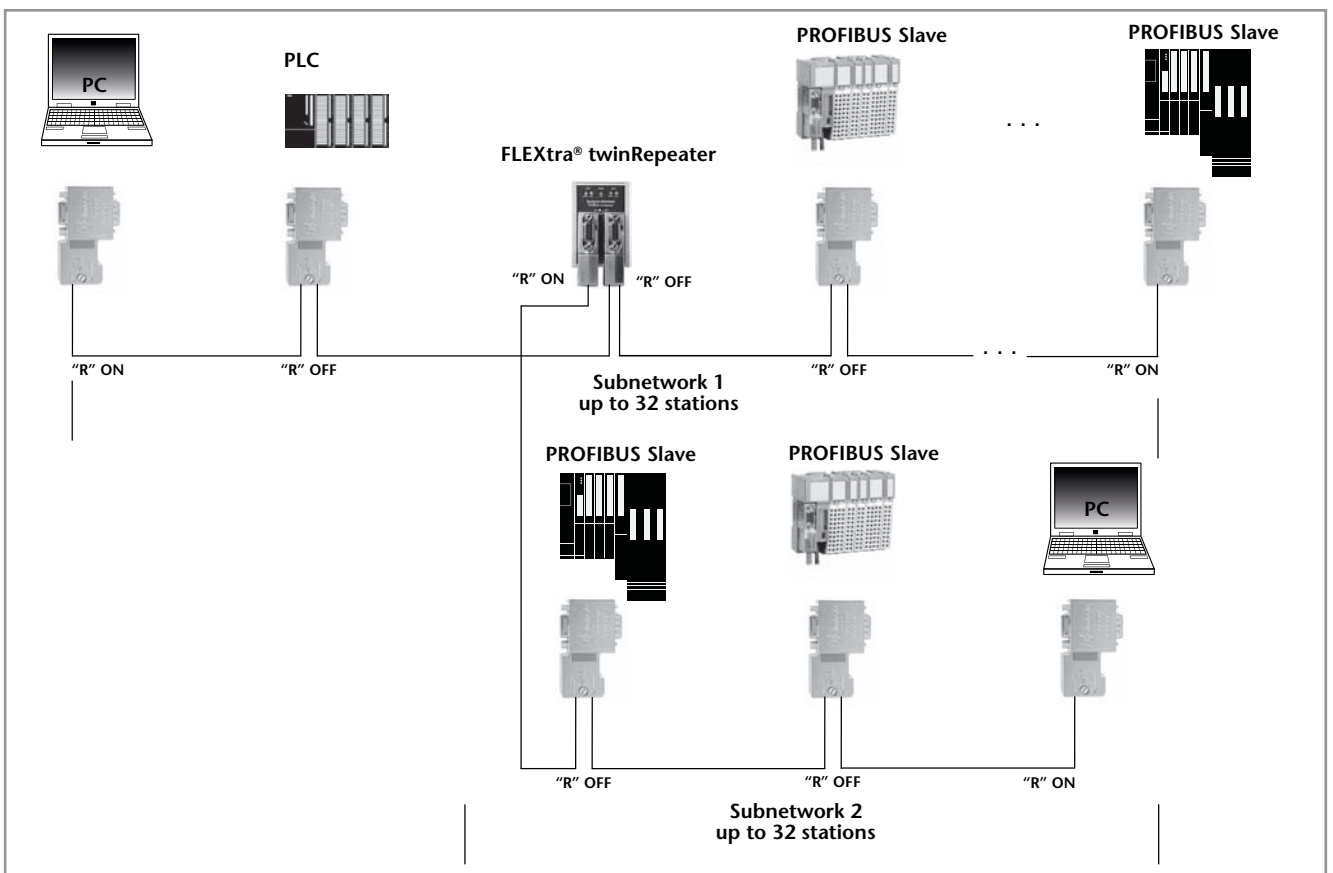

Application example FLEXtra® twinRepeater with spur lines

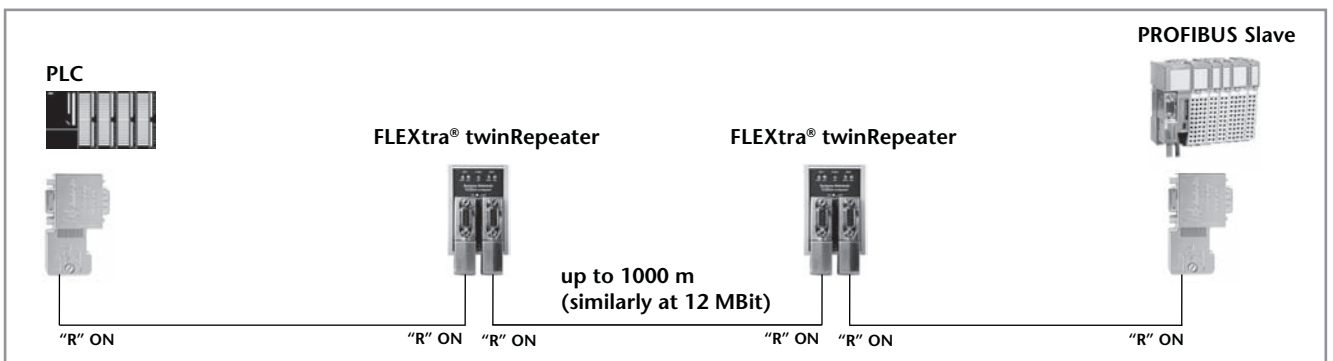

Application example FLEXtra® twinRepeater with long distances

FLEXtra® multiRepeater 4-way/6-way, PROFIBUS Repeater



FLEXtra® multiRepeater 4-way, 6-way

The new FLEXtra® multiRepeater from Systeme Helmholtz GmbH is a multiple PROFIBUS Repeater. It is designed to be mounted on a DIN rail. The FLEXtra® multiRepeater regenerates the electrical signal arriving on a bus cable and retransmits it (bit reshaping and retransmission).

The level, edge steepness and mark-to-space ratio of the signals are reproduced exactly. It supports transmission rates of 9.6 kbps to 12 Mbps and detects the rate automatically.

The multiRepeater can be used to extend the bus, to increase the number of stations on the bus, and to expand the plant. Use in MPI networks is also possible. As a special application, the FLEXtra® multiRepeater enables a star network with autonomous segments. The status LEDs integrated for each segment provide a fast overview of the bus status.

Moreover, the FLEXtra® multiRepeater ensures electrical isolation between the PROFIBUS segments. The multiRepeater also has a DIP switch for disconnecting individual segments and a switch for disconnecting all segments. The segments are disconnected but each segment remains separately functional. PROFIBUS connectors are required for connection to the PROFIBUS cable.

Ordering Data	Order No.
FLEXtra® multiRepeater 4-way (incl. instruction)	700-972-4AA02
FLEXtra® multiRepeater 6-way (incl. instruction)	700-972-6AA02

Features

- Building star networks
- Plant expansion up to 6 segments with a single device
- Increased number of stations on the bus
- Deployable for bus extension or as a spur line
- Can also be used in MPI networks
- Status LEDs for each segment
- Repeating function can be deactivated for each segment or completely
- Electrical isolation of all segments



FLEXtra multiRepeater

Transmission Rate	max. segment length
9.6 kbps	1000 m
19.2 kbps	1000 m
45.45 kbps	1000 m
93.75 kbps	1000 m
187.5 kbps	1000 m
500 kbps	400 m
1.5 Mbps	200 m
3 Mbps	100 m
6 Mbps	100 m
12 Mbps	100 m

Technical Data		
	4-way	6-way
Dimensions (D x W x H mm)	35 x 94 x 72	35 x 137 x 72
Weight	Approx. 180 g	Approx. 275 g
Power supply	18 ... 30 VDC	18 ... 30 VDC
Output voltage	5 V, 150 mA per Segment	5 V, 150 mA per Segment
Potential separation	500 V	500 V
Current consumption max.	280 mA	400 mA
Segment connection	Via PROFIBUS Connector	Via PROFIBUS Connector
PROFIBUS interface		
Transmission rate max.	12 Mbps autodetection	12 Mbps autodetection
Protocol	PROFIBUS-DP to EN 61 158-2	PROFIBUS-DP to EN 61 158-2
Surrounding air temp. Transport and storage temperature	0 °C ... +60 °C -25 °C ... +75 °C	0 °C ... +60 °C -25 °C ... +75 °C
Degree of protection	IP 20	IP 20

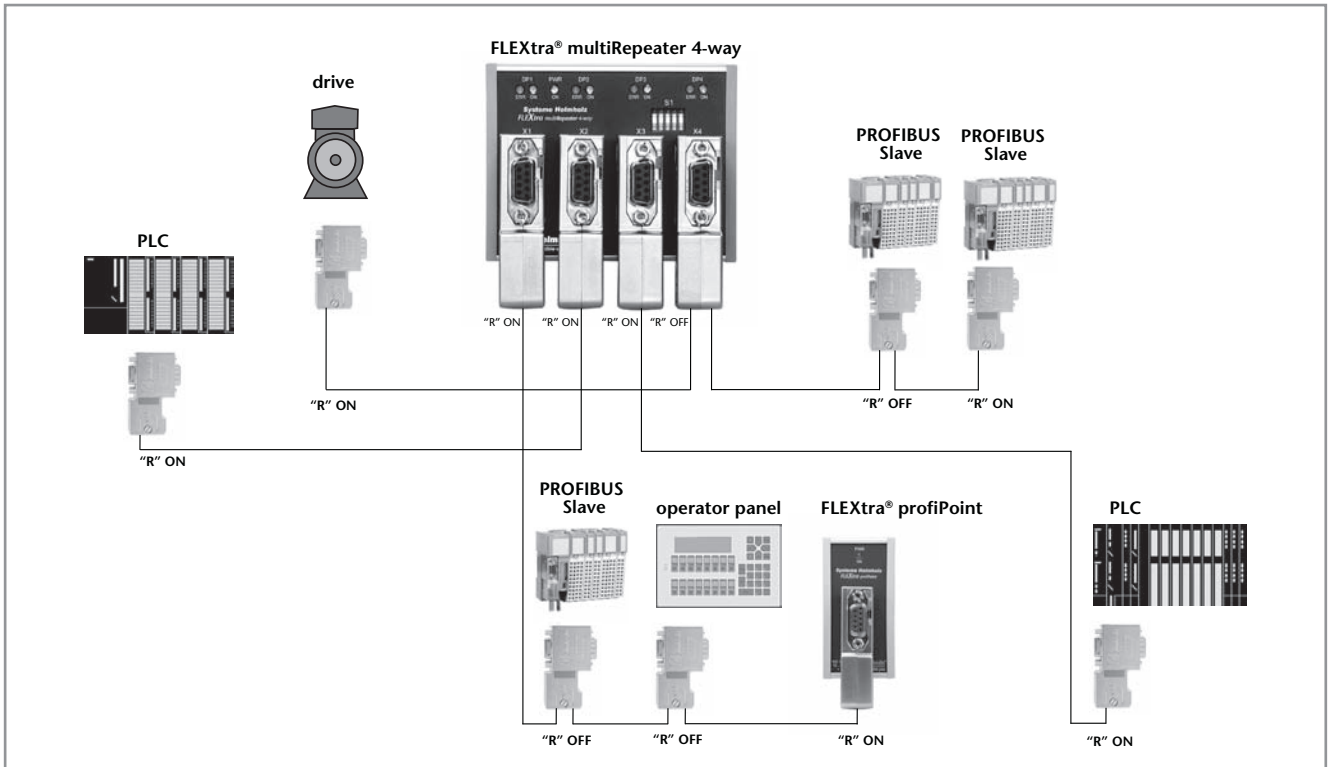

Application example FLEXtra® multiRepeater 4-way

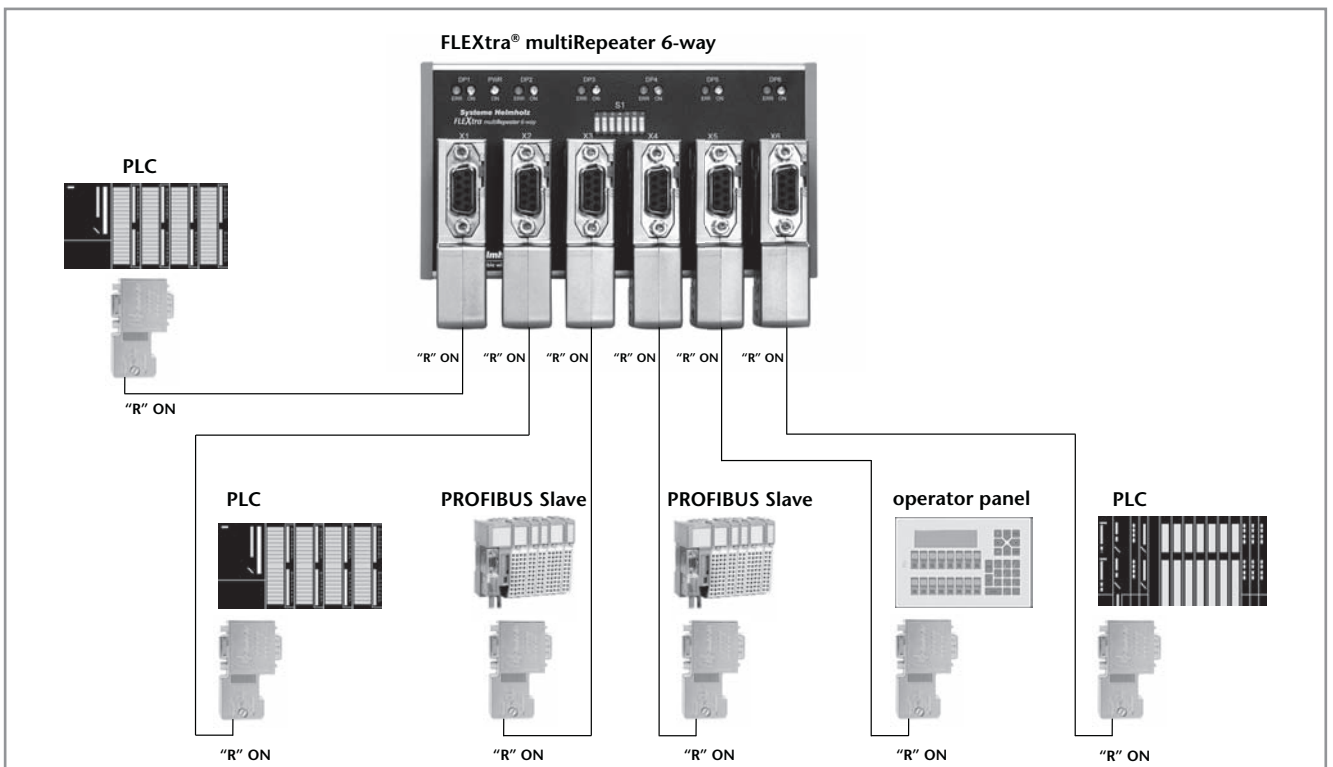

Application example FLEXtra® multiRepeater 6-way

PROFIBUS Compact Repeater



PROFIBUS Compact Repeater

The new PROFIBUS Compact Repeater from Systeme Helmholtz GmbH is a fully functional PROFIBUS repeater. It is applicable very flexible thanks to its very small style. The repeater covers transmission rates from 9.6 Kbps to 12 Mbps. The transmitted signals are regenerated by the repeater and resent (Bit-Reshaping and Retransmission), so trouble in the line are mostly avoided.

In term of price as well as in term of technical reasons the PROFIBUS Compact Repeater is a real option for multitude applications instead of using standard repeaters.

It can be used for bus extensions (up to 1 km with 2 PROFIBUS Compact Repeaters), increase of the stations as well as for plant extensions.

The operation in MPI networks is also possible.

As a special application option the PROFIBUS Compact Repeater offers you the possibility the usage of drop cables as standalone segments. Therefore it can be plugged directly on the PG port of a built in PROFIBUS connector.

Due to the compact shape no additional room is needed in the cabinet, as the PROFIBUS Compact Repeater can be used instead of PROFIBUS Connector, or simply plugged onto a node in the PROFIBUS Network.

Furthermore no separate power supply is needed, as the PROFIBUS Compact Repeater is using the 5 V power supply, every PROFIBUS device possesses for the terminating resistor. The PROFIBUS Compact Repeater generates an isolation between both PROFIBUS segments. The integrated status LEDs provide a fast overview on the current Bus status.

Ordering Data	Order No.
PROFIBUS Compact Repeater (incl. instruction)	700-972-ORB12
Stripping tool for PROFIBUS	700-972-6AA00

Features

- A real alternative to conventional PROFIBUS repeaters
- No additional space needed in the cabinet
- Very flexible in its use
- Can be used as a bus extension or spur line
- Increases the number of stations on the bus
- System expansion
- Can also be used in MPI networks
- Status LEDs
- 24 V supply is not necessary
- 5 V power supply direct from the PROFIBUS, with that it's usable on every PROFIBUS device
- Electrical isolation



Transmission Rate	max. segment length
9.6 kbps	1000 m
19.2 kbps	1000 m
45.45 kbps	1000 m
93.75 kbps	1000 m
187.5 kbps	1000 m
500 kbps	400 m
1.5 Mbps	200 m
3 Mbps	100 m
6 Mbps	100 m
12 Mbps	100 m

Technical Data	
Dimensions (D x W x H mm)	64 x 40 x 17
Weight	Approx. 40 g
Power supply	
Voltage	+ 5 V DC
Current consumption	typ. 100 mA
Connection	SUB-D, 9-way
PROFIBUS interface	
Transmission rate	max. 9.6 kbps to 12 Mbps autodetection
Protocol	PROFIBUS-DP per EN 50 170
Connection	SUB-D, 9-way
Max. outside diameter	8.0 mm
PROFIBUS cable	60/70 °C copper wire up to 1.0 mm ²
Connection type	4 terminals
Environmental pollution degree	2
Ambient temperature	0 °C ... +60 °C
Transport and storage temperature	-25 °C ... +75 °C
Degree of protection	IP 20

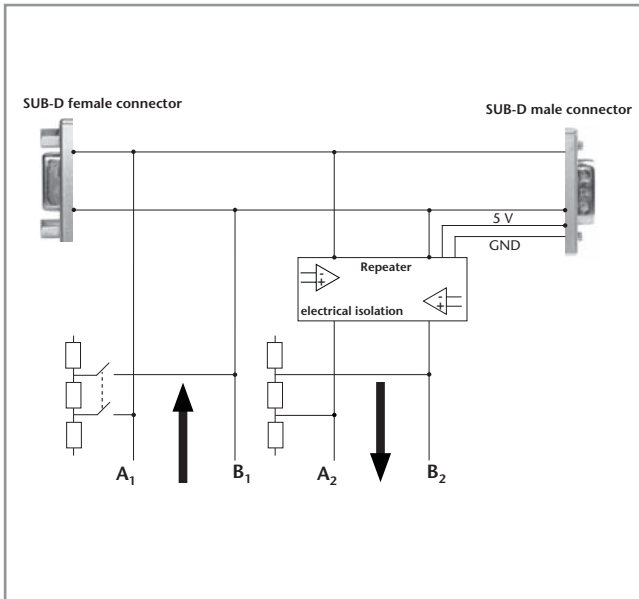

Internal Design

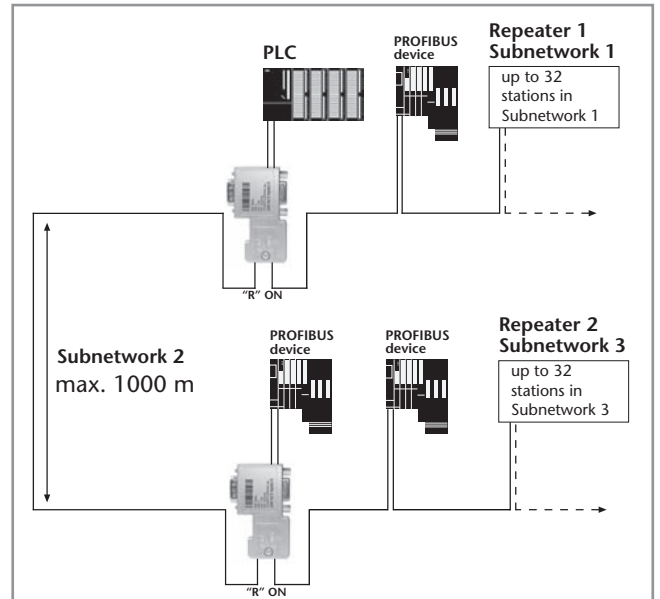

Application example with long distances

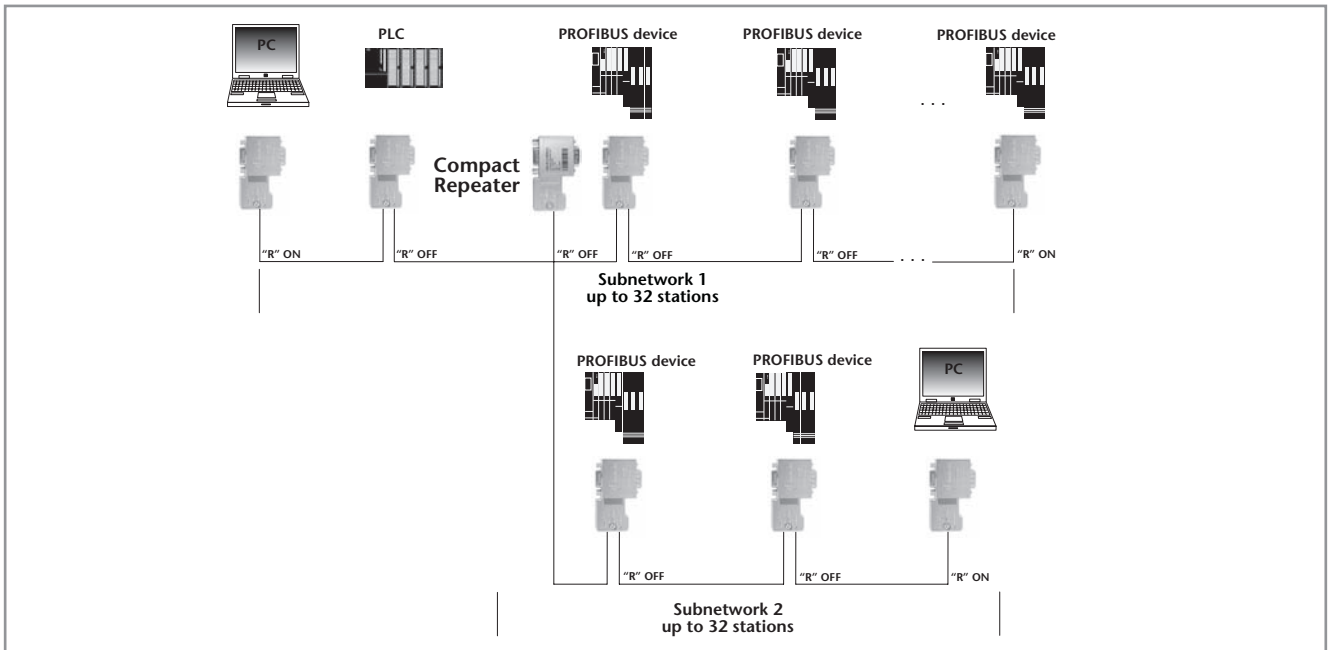

Application example with spur lines

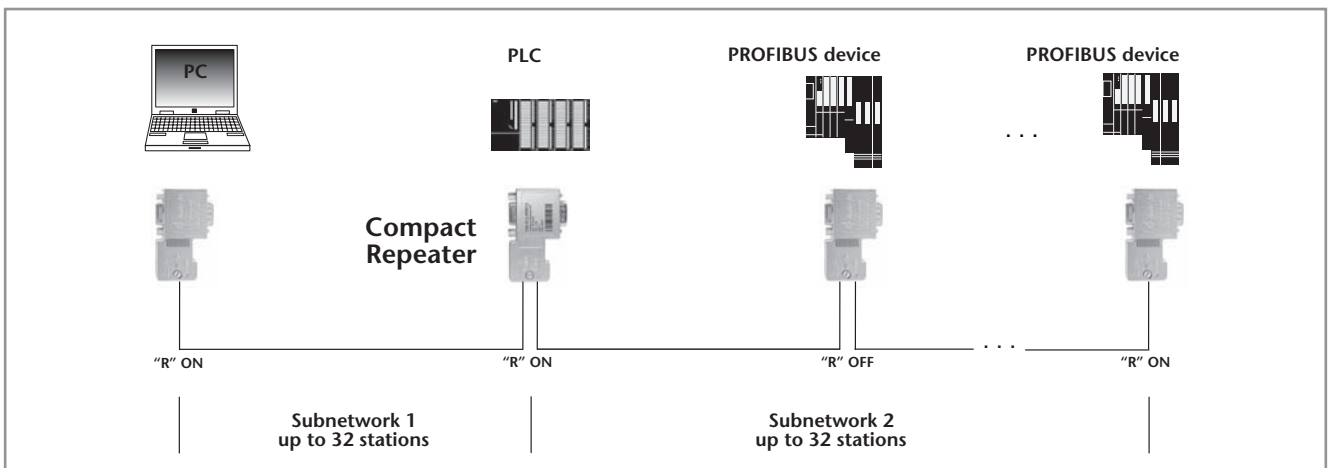

Application example with more than 32 stations



OPTopus, PROFIBUS Optical Link

The OPTopus PROFIBUS Optical Link from Systeme Helmholz GmbH is a full PROFIBUS repeater with an integrated FO interface. The OPTopus permits transmission rates of 9.6 kbps to 12 Mbps on the PROFIBUS with automatic detection of the baud rate. With its optical signal transmission, it offers complete electrical isolation between the PROFIBUS stations and PROFIBUS subnetworks. A further advantage of the OPTopus is its insensitivity to EMC influences.

Because of its compact design, no additional space in the control cabinet is required for deployment because the OPTopus PROFIBUS Optical Link can be used instead of a PROFIBUS connector and is simply plugged into a station in the PROFIBUS network. Moreover, no separate power supply is required because the OPTopus uses the 5 V power supply that every PROFIBUS device provides for the terminating resistor.

The transmission signals are converted into optical signals by the OPTopus and are transmitted on the FO line in this way. The signals are also regenerated with their edge steepness, level and mark-to-space ratio. The OPTopus PROFIBUS is available with 3 different optical interfaces and can therefore also be perfectly combined with existing transmission systems. It is suitable for POF¹⁾ and PCF¹⁾ FO. For the close range up to 65 m, an optical transmission line can be set up very quickly and without great effort using POF¹⁾. The scope of supply of the OPTopus contains the appropriate connectors for this purpose. Only a standard POF¹⁾ FO is additionally required. For larger distances up to 250 m, PCF¹⁾-FOs can be used. The optical interface of the OPTopus transmits in the visual range (650 nm red light), which enables initial checking of the optical transmission line without expensive measuring instruments.

For many applications, the OPTopus PROFIBUS Optical Link is a real alternative to conventional optical signal converters, both technically and in terms of price. It additionally provides the advantages of a normal repeater. Bus extension, increase in the number of stations and expansion of your plant. Use in MPI networks is also possible.

As a special application, the PROFIBUS Optical Link permits the building of spur lines as autonomous segments.

For this purpose, it can be plugged into programming device port of an existing PROFIBUS connector.

The OPTopus PROFIBUS Optical Link for diagnostic purposes provides a traffic LED and an error LED for the PROFIBUS, and for the optical interface. These keep you informed at all times about the bus status and ensure targeted troubleshooting.

Features

- PROFIBUS baud rate (9.6 kbps to 12 Mbps), autodetect
- Compact design, not larger than a Helmholz PROFIBUS connector
- LED display of traffic/bus errors separately for FO and PROFIBUS segment
- Switchable terminating resistor with optical display
- Complete electrical isolation
- Insensitive to EMC influences
- No 24 V power supply required
- Powered directly with 5 V through the PROFIBUS station
- Available with 3 different optical interfaces (SMA, BFOC²⁾, Versatile Link³⁾)
- Suitable for POF¹⁾ and PCF¹⁾ FO
- Range: Cable length POF¹⁾ 65 m
Cable length PCF¹⁾ 250 m
- POF¹⁾-FO plug-in connector supplied

There is also a power LED that provides information about the operating status and status of the terminating resistors.

Technical Data	
Dimensions in mm (D x W x H)	Approx. 64 x 40 x 17
Weight	Approx. 40 g
Power supply	
Voltage	+ 5 V DC
Current consumption	typ. 100 mA
Connector socket	SUB-D 9-way
PROFIBUS interface	
Transmission rate	9.6 kbps to 12 Mbps detected automatically
Protocol	PROFIBUS-DP acc. to EN 61 158-2:2011-09
Connection	Socket, SUB-D, 9-way
Optical interface	
Wavelength	650 nm
Numerical aperture transmit diode	0.50
Launchable optical power/ receiver sensitivity	
POF ¹⁾ 980/1000 μm	-7.5 dBm/-20 dBm
PCF ¹⁾ 200/230 μm	-18 dBm/-22 dBm
Overdrive limit receiver	-3 dBm
Max. transmission distance	
POF ¹⁾ 980/1000 μm (160 dB/km)	Up to 65 m
PCF ¹⁾ 200/230 μm (10 dB/km)	Up to 250 m
Ambient temperature	0 °C ... +60 °C
Transport and storage temperature	-25 °C ... +75 °C
Degree of protection	IP 20

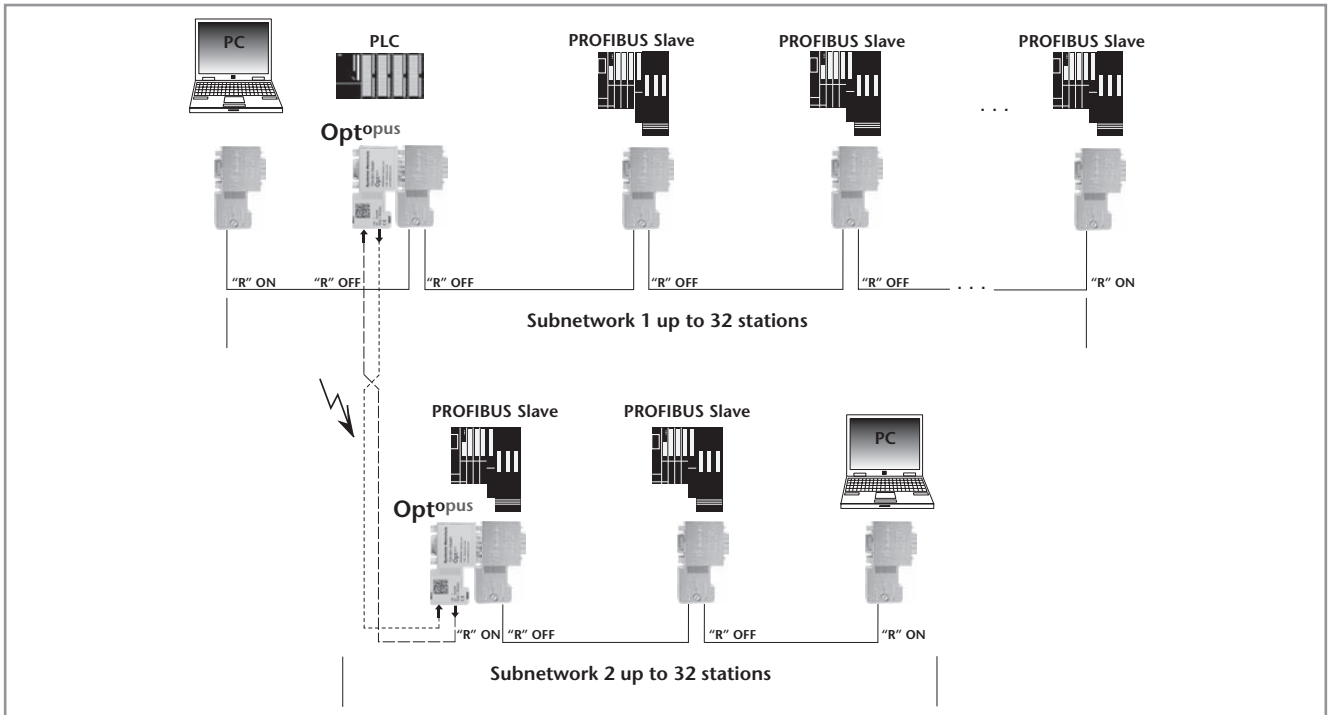

Generation of a completely electrically isolated subnetwork.

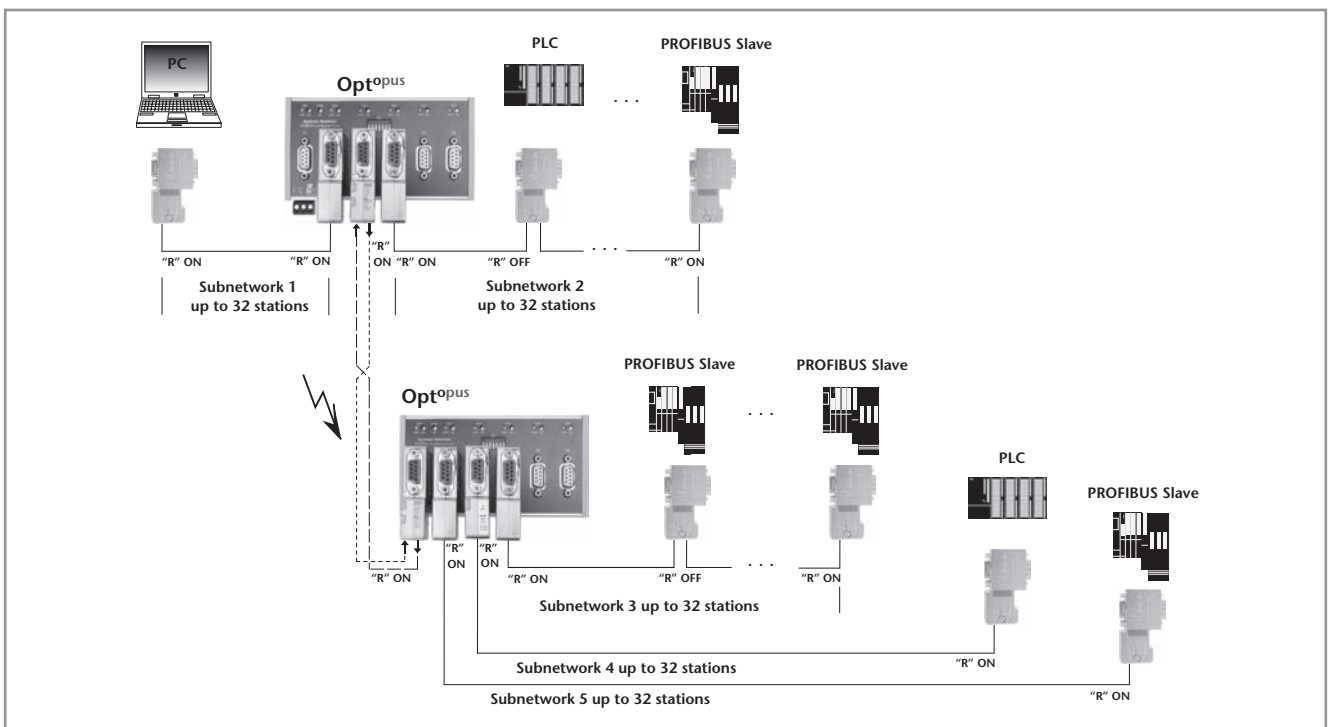

Establishment of a link between two repeaters that is not subject to EMC interference.

Note

1) PCF stands for Polymer Cladded Fiber and is equivalent to HCS (HCS is a brand of Ensign-Bickford Optics Company). POF stands for Polymeric Optical Fiber.

For the PCF/HCS assembling are extra PCF/HCS connectors, and a special assembly tool according to the required plug connection-technology required. You get the corresponding PCF/HCS plugs from your FO cable supplier.

2) BFOC stands for Bajonett Fiber Optic Connector. This type of connector is function compatible with ST connectors (ST is registered trademark of company AT&T).

3) The Versatile Link connector is function compatible with HP-Simplex/Duplex connectors.

Ordering Data	Order No.
OPTopus, PROFIBUS Optical Link Versatile Link³⁾ , 650 nm, POF/PCF ¹⁾ (incl. instruction, POF plug in connector)	700-991-1AA01
BFOC²⁾ , 650 nm, POF/PCF ¹⁾ (incl. instruction, POF plug in connector)	700-992-1AA01
SMA , 650 nm, POF/PCF ¹⁾ (incl. instruction, POF plug in connector)	700-993-1AA01

FLEXtra® FO, PROFIBUS Optical Hub



FLEXtra® FO, PROFIBUS Optical Hub

Features

- PROFIBUS repeater with 5 optical MPI/PROFIBUS interfaces
- Can perfectly be combined with existing transmission systems
- PROFIBUS baud rate (9.6 kbps to 12 Mbps), autodetect
- Disconnection of all or individual segments possible
- Use in high vulnerable emc areas
- Suitable for POF¹⁾ and PCF¹⁾ FO
- Available with 3 different optical interfaces (SMA, BFOC²⁾, Versatile Link³⁾)
- Range: Cable length POF¹⁾ 65 m
Cable length PCF¹⁾ 250 m
- LED display of traffic/bus errors separately for every FO and PROFIBUS segment

The FLEXtra® FO is a PROFIBUS repeater with the capability of expansion by 2 (FLEXtra® FO 650-2) or by 5 (FLEXtra® FO 650-5) optical MPI/PROFIBUS segments.

It translates an electrical MPI/PROFIBUS interface into an optical MPI/PROFIBUS interface and vice-versa.

The FLEXtra® FO permits transmission rates of 9.6 kbps to 12 Mbps on the PROFIBUS with automatic detection of the baud rate. With its optical signal transmission, it offers complete electrical isolation between the PROFIBUS stations and PROFIBUS sub networks.

A further advantage of the FLEXtra® FO is its being unaffected by EMC influences.

The transmission signals are converted into optical signals by the FLEXtra® FO and are transmitted on the FO line in this way. In addition the flank slope, level and duty cycle of the signals are regenerated. The FLEXtra® FO is available with 3 different optical interfaces and can therefore also be perfectly combined with existing transmission systems. It is suitable for POF¹⁾ and PCF¹⁾ FO. For the close range up to 65 m, an optical transmission line can be set up very quickly and without great effort using POF¹⁾. For longer distances up to 250 m, PCF¹⁾ FOs can be used.

The optical interface of the FLEXtra® FO transmits in the visual range (650 nm red light), which enables initial checking of the optical transmission line without expensive measuring instruments.

The FLEXtra® FO incorporates integrated status LEDs for every segment, for use in diagnosis. These provide a continual status of the busses and the optical interfaces and assist with detailed fault finding. The FLEXtra® FO also has DIP switches for disconnecting all or individual segments. The segments are disconnected but each segment remains separately functional.

Note

1) PCF stands for Polymer Cladded Fiber and is equivalent to HCS (HCS is a brand of Ensign-Bickford Optics Company). POF stands for Polymeric Optical Fiber.

Connector plugs for the optical connection are not included. These are available from your FO supplier.

2) BFOC stands for Bajonett Fiber Optic Connector. This type of connector is function compatible with ST connectors (ST is registered trademark of company AT&T).

3) The Versatile Link connector is function compatible with HP-Simplex/Duplex connectors.

Ordering Data	Order No.
FLEXtra® FO 650-2, PROFIBUS Optical Hub	
Versatile Link ³⁾ , 650 nm, POF/PCF ¹⁾ (incl. instruction)	700-996-2CA01
BFOC ²⁾ , 650 nm, POF/PCF ¹⁾ (incl. instruction)	700-996-2AA01
SMA, 650 nm, POF/PCF ¹⁾ (incl. instruction)	700-996-2BA01
FLEXtra® FO 650-5, PROFIBUS Optical Hub	
Versatile Link ³⁾ , 650 nm, POF/PCF ¹⁾ (incl. instruction)	700-996-5CA01
BFOC ²⁾ , 650 nm, POF/PCF ¹⁾ (incl. instruction)	700-996-5AA01
SMA, 650 nm, POF/PCF ¹⁾ (incl. instruction)	700-996-5BA01

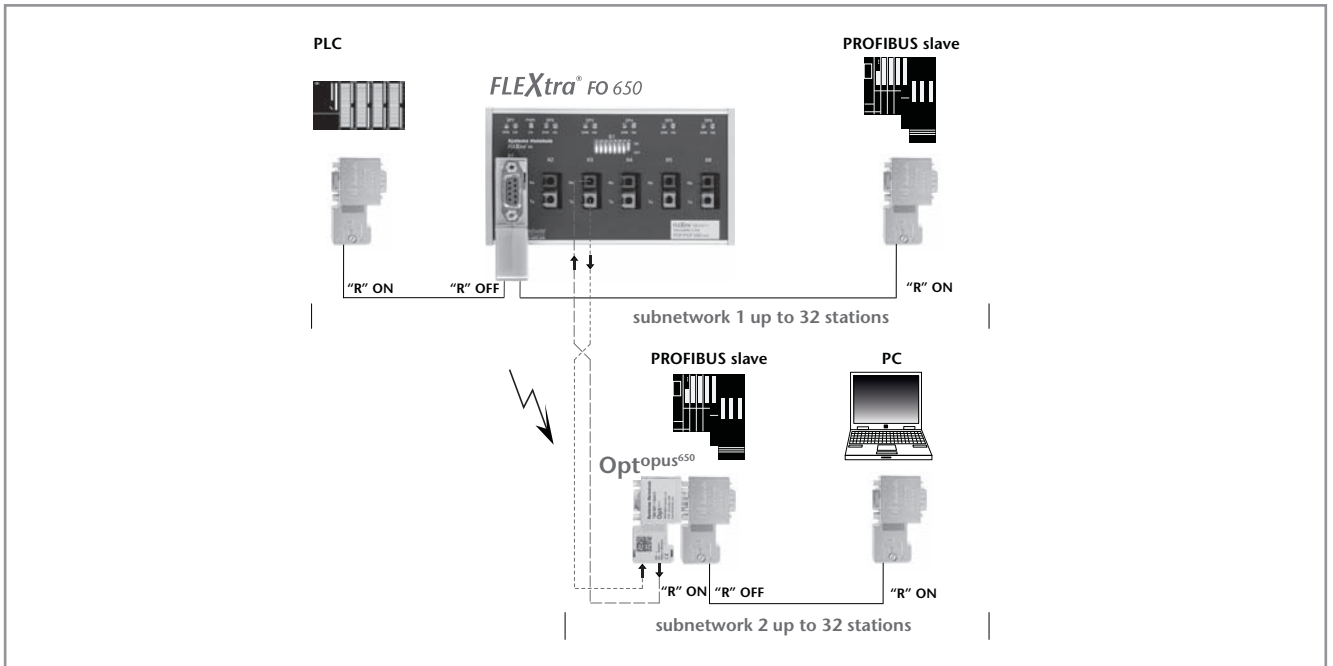

Produce a fully electrical isolated subnetwork.

Technical Data		
	650-2	650-5
Dimensions in mm (D x W x H)	35 x 70 x 72	35 x 137 x 72
Weight	ca. 125 g	ca. 250 g
Power supply		
• Voltage	+18–30 V DC	+18–30 V DC
• Electrical isolation	500 V	500 V
• Current consumption		
• incl. 5 V-consumer load	max. 200 mA	max. 400 mA
• incl. 24 V-consumer load	max. 400 mA	max. 600 mA
Output voltage Port X1		
• Voltage 1	5 V, max. 150 mA	5 V, max. 150 mA
• Voltage 2	+18–30 V DC, max. 200 mA (like supply voltage)	+18–30 V DC, max. 200 mA (like supply voltage)
Potential separation	500 V	500 V
Current consumption	max. 200 mA	400 mA
Segment connection		
Port 1	SUB-D 9-way	SUB-D 9-way
Port 2–5	BFOC ²⁾ , SMA, Versatile Link ³⁾	BFOC ²⁾ , SMA, Versatile Link ³⁾
PROFIBUS interface		
Transmission rate	9.6 19.2 45.45 93.75 187.5 500 Kbps 1.5 3 6 and 12 Mbps autodetection	9.6 19.2 45.45 93.75 187.5 500 Kbps 1.5 3 6 and 12 Mbps autodetection
Protocol	PROFIBUS-DP acc. to EN 61 158-2:2011-09	PROFIBUS-DP acc. to EN 61 158-2:2011-09
Optical interface		
Wavelength	650 nm	650 nm
Numerical aperture transmit diode	0.50	0.50
Launchable optical power/ receiver sensitivity		
POF ¹⁾ 980/1000 μm	-7.5 dBm/-20 dBm	-7.5 dBm/-20 dBm
PCF ¹⁾ 200/230 μm	-18 dBm/-22 dBm	-18 dBm/-22 dBm
Overdrive limit receiver	-3 dBm	-3 dBm
Max. transmission distance		
POF ¹⁾ 980/1000 μm (160 dB/km)	Up to 65 m	Up to 65 m
PCF ¹⁾ 200/230 μm (10 dB/km)	Up to 250 m	Up to 250 m
Ambient temperature	0 °C to +60 °C	0 °C to +60 °C
Transport and storage temperature	-25 °C to +75 °C	-25 °C to +75 °C
Degree of protection	IP 20	IP 20



viBlu, PROFIBUS radio system

The PROFIBUS radio system viBlu is a virtual cable that permits the linking of distributed I/Os or intelligent devices (e.g. rotating tables, conveyor systems, etc.) by means of radio.

Data transmission is performed via Bluetooth in the license-exempt 2.4 GHz band and supports the PROFIBUS baud rates of 9.6 kbps to 1.5 Mbps.

Depending on the local circumstances, transmission distances of up to 100 m are possible.

Use of the PROFIBUS radio module is possible in single-master, and in multi-master systems and permits full PROFIBUS expansion. At present, only PROFIBUS-DP-slaves are supported behind a viBlu slave.

The PROFIBUS radio module is powered with 24 V DC from an external power supply.

A 9-way SubD socket is used for the PROFIBUS connection. Moreover, an USB port is integrated to be used for parameterization of the radio link.

5 LEDs on the device provide information about the operating status on the PROFIBUS and on the radio side.

Antennas with a larger gain can optionally be connected to the radio module through an RP-SMA socket on the device to optimize the range.

Outside Europe, use of antennas with a gain of more than 10 dBi is permitted, enabling radio-relay systems with a range, for example, of up to a few kilometers.

Accessory-Note

For antennas, see page 34.

Ordering Data	Order No.
viBlu 100 Master* connection up to 1 Slave; 187.5 kbps	700-761-PFM11
viBlu 100 Slave*	700-761-PFS11
viBlu 200 Master* connection up to 3 Slaves; 1.5 Mbps	700-762-PFM11
viBlu 200 Slave*	700-762-PFS11
*(incl. manual, CD with software)	

1) STEP is a registered trademark of Siemens AG.

Features viBlu 200

- Settable transmission power
- Up to 3 radio slaves on one radio master
- Bluetooth in the license-exempt 2.4 GHz band
- Up to 1.5 Mbps PROFIBUS-DP
- Simple configuration via USB interface
- No configuration necessary in STEP¹⁾ 7
- Extensive diagnostics of the radio interface
- Ranges extending to over 100 m

Features viBlu 100

As for viBlu 200 but with following restrictions:

- Only 1 DP-slave
- Only up to 187.5 kbps PROFIBUS-DP



Technical Data		
	viBlu 100	viBlu 200
Dimensions (D x W x H mm)	130 x 68 x 30	130 x 68 x 30
Weight	Approx. 170 g	Approx. 170 g
Power supply		
Voltage	DC 24 V (18 ... 30 V)	DC 24 V (18 ... 30 V)
Current consumption	Typ. 100 mA	Typ. 100 mA
PROFIBUS		
Type	RS485, isolated	RS485, isolated
Number of DP/slaves	1 slave	3 slaves
Transmission rate	9.6 kbps ... 187.5 kbps, autodetection	9.6 kbps ... 1.5 Mbps, autodetection
Connection	SUB-D, 9-way	SUB-D, 9-way
Radio interface		
Protocol	Bluetooth	Bluetooth
Range	Up to more than 100 m	Up to more than 100 m
Baud rate	Up to 700 kbps	Up to 700 kbps
Antenna connection	RP-SMA socket	RP-SMA socket
Ambient temperature	0 °C ... 60 °C	0 °C ... 60 °C
Indicators	5 LEDs	5 LEDs
Degree of protection	IP 20	IP 20

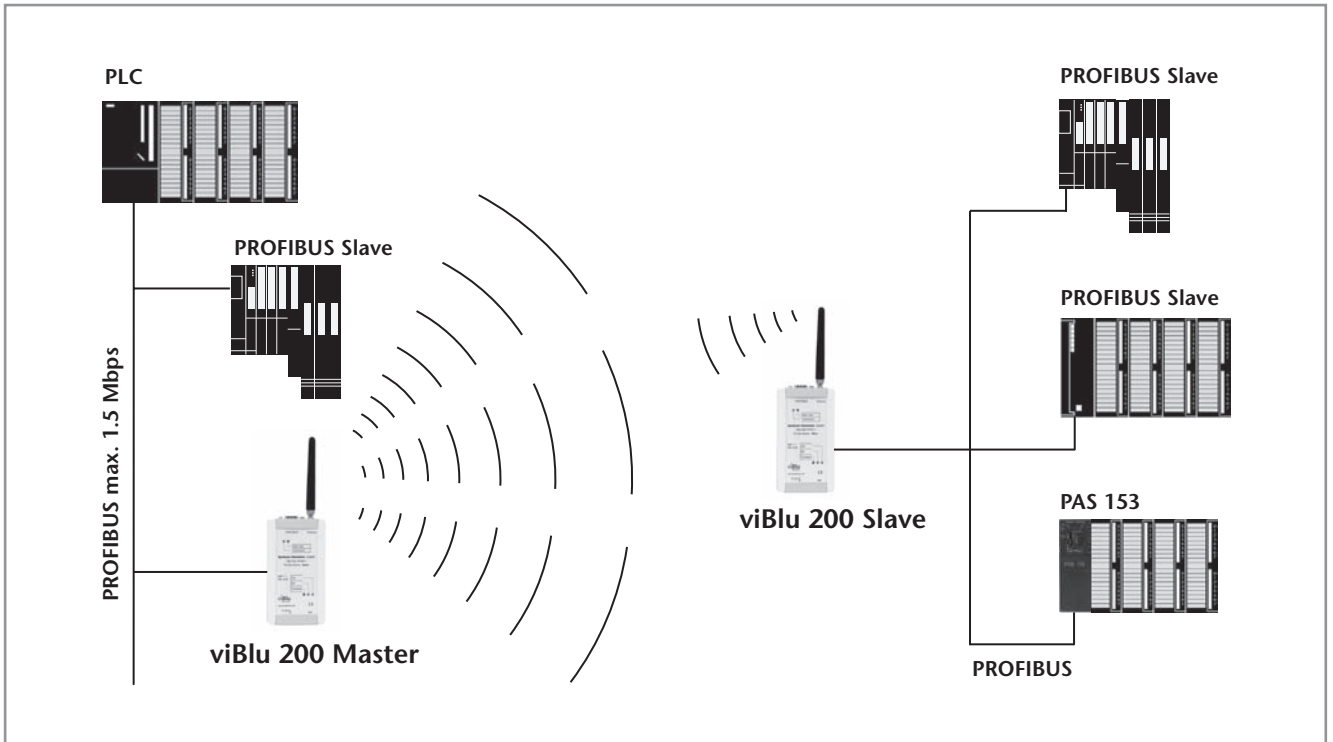

Application example viBlu 200 with a radio slave and up to 3 PROFIBUS-DP stations

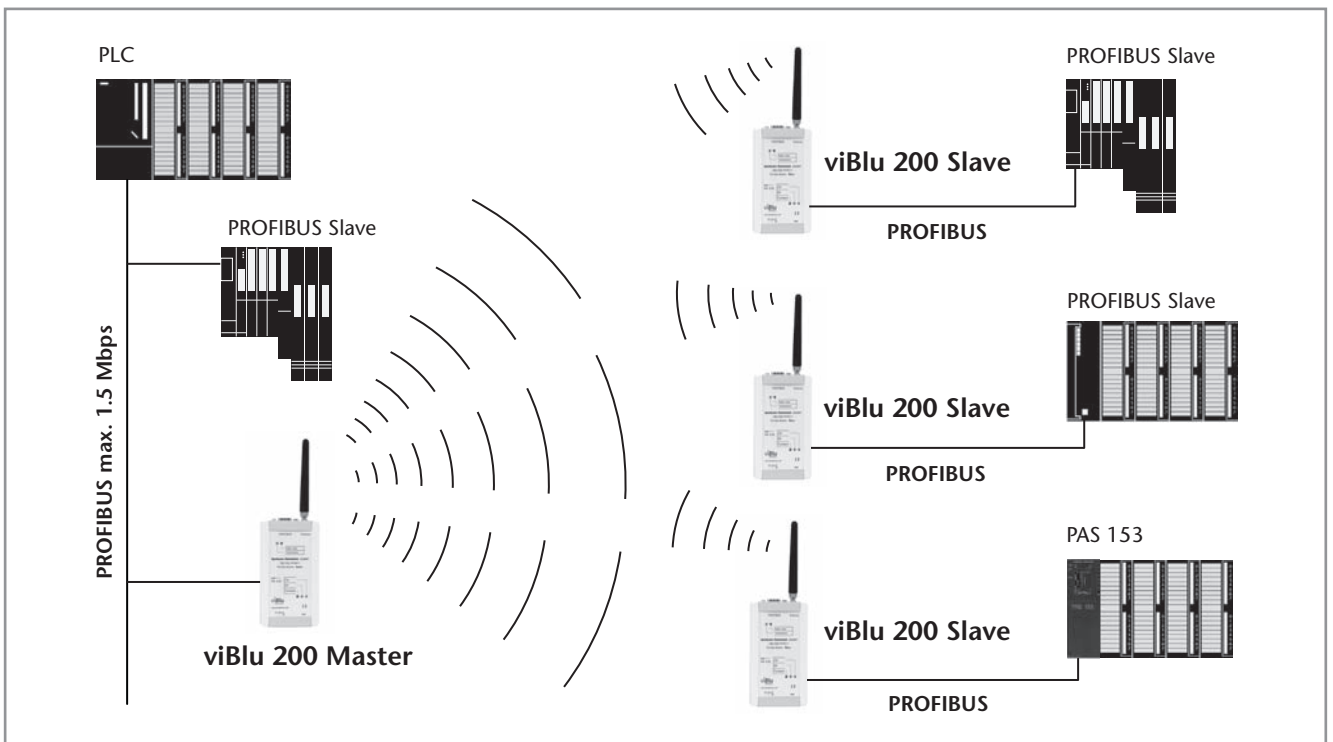

Application example viBlu 200 with 3 radio slaves



PAS 153 viBlu, distributed PROFIBUS radio interface

The PAS 153 viBlu distributed PROFIBUS radio interface from Systeme Helmholtz GmbH is for linking digital and analog input and output modules to the PROFIBUS-DP by radio. Data transmission is performed via Bluetooth in the license-exempt 2.4 GHz band and supports the PROFIBUS baud rates of 9.6 kbps to 1.5 Mbps. Depending on the local circumstances, transmission distances of up to 100 m are possible.

Up to 16 modules can be connected to the PAS 153 viBlu. The PAS 153 viBlu is integrated into the Hardware Configurator of the programming system by a GSD file. The PAS 153 Interface performs all communication between the modular I/O device and the higher-level master unit on the PROFIBUS-DP. The inputs and outputs are assigned to the master in the configuration. Diagnostic information from the modules can be read out via the PAS 153 Interface in the usual way.

The PAS 153 viBlu radio interface supports all input/output modules from Systeme Helmholtz GmbH and numerous modules of the same type from other manufacturers.

The scope of modules supported can be extended at any time by a firmware update via the USB.

Antennas with a larger gain can optionally be connected to the radio module through an RP-SMA socket on the device to optimize the range. Outside Europe, use of antennas with a gain of more than 10 dBi is permitted, enabling radio-relay systems with a range, for example, up to several kilometers.

Moreover, a USB port is integrated to be used for parameterization of the radio link.

6 LEDs on the device provide information about the operating status on the PROFIBUS and on the radio side.

Accessory-Note

For antennas, see page 34.

Ordering Data	Order No.
PAS 153 viBlu 100 (incl. manual, CD with software)	700-763-PFS11
PAS 153 viBlu 200 (incl. manual, CD with software)	700-764-PFS11

Features PAS 153 viBlu 200

- Up to 16 modules can be plugged in
- Module diagnostics supported
- Can be used on standard Mounting rail
- Any combination of modules is possible (analog/digital)
- GSD file is supplied
- Settable transmission power
- Up to 3 slaves in the radio network
- Bluetooth in the license-exempt 2.4 GHz band
- Up to 1.5 Mbps PROFIBUS-DP
- Simple configuration of the radio parameters through USB
- Extensive diagnostics of the radio interface
- Ranges extending to over 100 m

Features PAS 153 viBlu 100

As for the PAS 153 viBlu 200, but with the following restrictions:

- Only 1 DP slave in the radio network
- Only up to 187.5 kbps PROFIBUS-DP

Technical Data		
	PAS 153 viBlu 100	PAS 153 viBlu 200
Dimensions in mm (D x W x H)	116 x 40 x 125	116 x 40 x 125
Weight	Approx. 270 g	Approx. 270 g
Power supply		
Voltage	24 V DC (18 ... 30 V)	24 V DC (18 ... 30 V)
Current consumption	Typ. 700 mA	Typ. 700 mA
Output voltage	5 V	5 V
Output current at 5 V DC max.	1.5 A (for backplane bus)	1.5 A (for backplane bus)
Number of modules max.	16, including 8 analog	16, including 8 analog
Addressing range	128 bytes for inputs 128 bytes for outputs	128 bytes for inputs 128 bytes for outputs
PROFIBUS		
Transmission rate	9.6 kbps to 187.5 kbps, detected automatically	9.6 kbps to 1.5 Mbps, detected automatically
Connection type	SUB D socket, 9-way	SUB D socket, 9-way
Radio interface		
Protocol	Bluetooth	Bluetooth
Number of slaves on the radio network	1 slave	3 slaves
Range	Up to more than 100 m	Up to more than 100 m
Baud rate	Up to 700 kbps	Up to 700 kbps
Antenna connection	RP-SMA socket	RP-SMA socket
Ambient temperature	0 °C ... +60 °C	0 °C ... +60 °C
Transport and storage temperature	-25 °C ... +60 °C	-25 °C ... +60 °C
Displays	6 LEDs	6 LEDs
Degree of protection	IP 20	IP 20

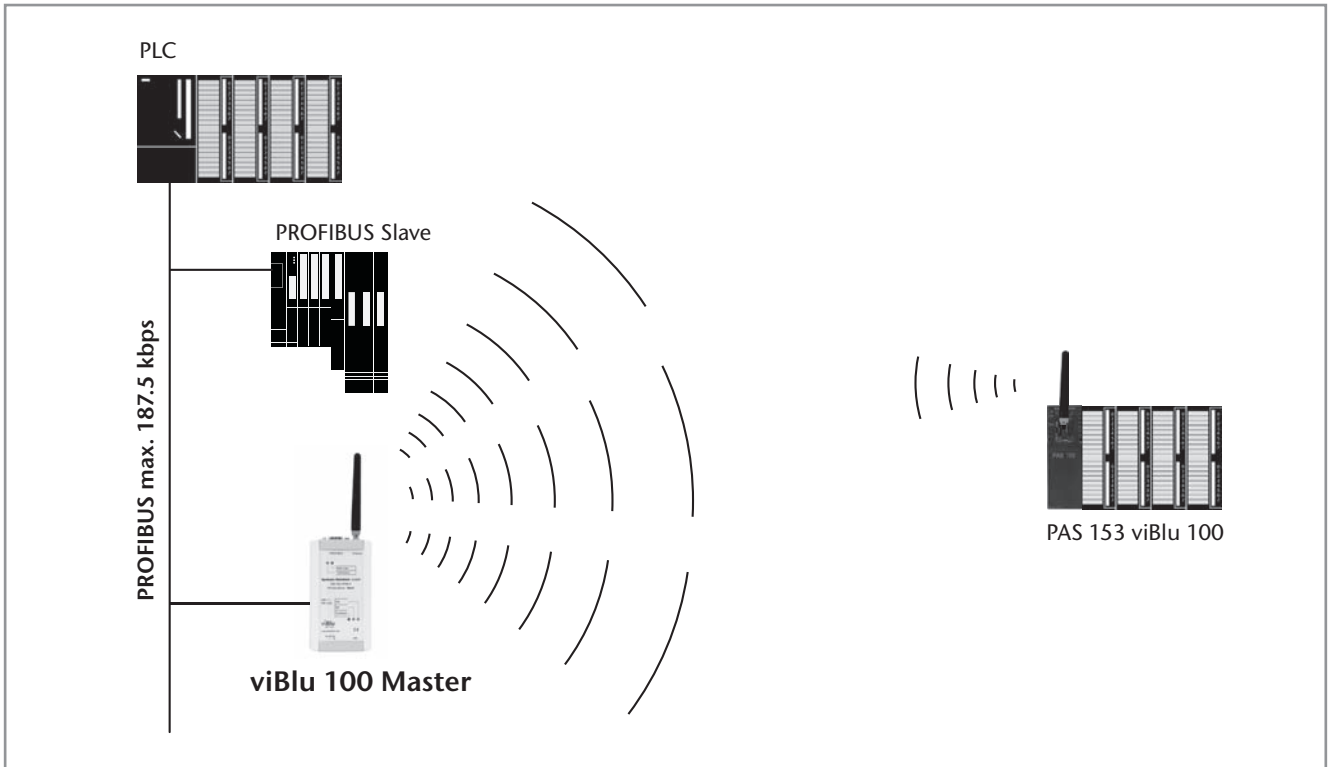

Application example PAS 153 viBlu 100 with 1 Slave

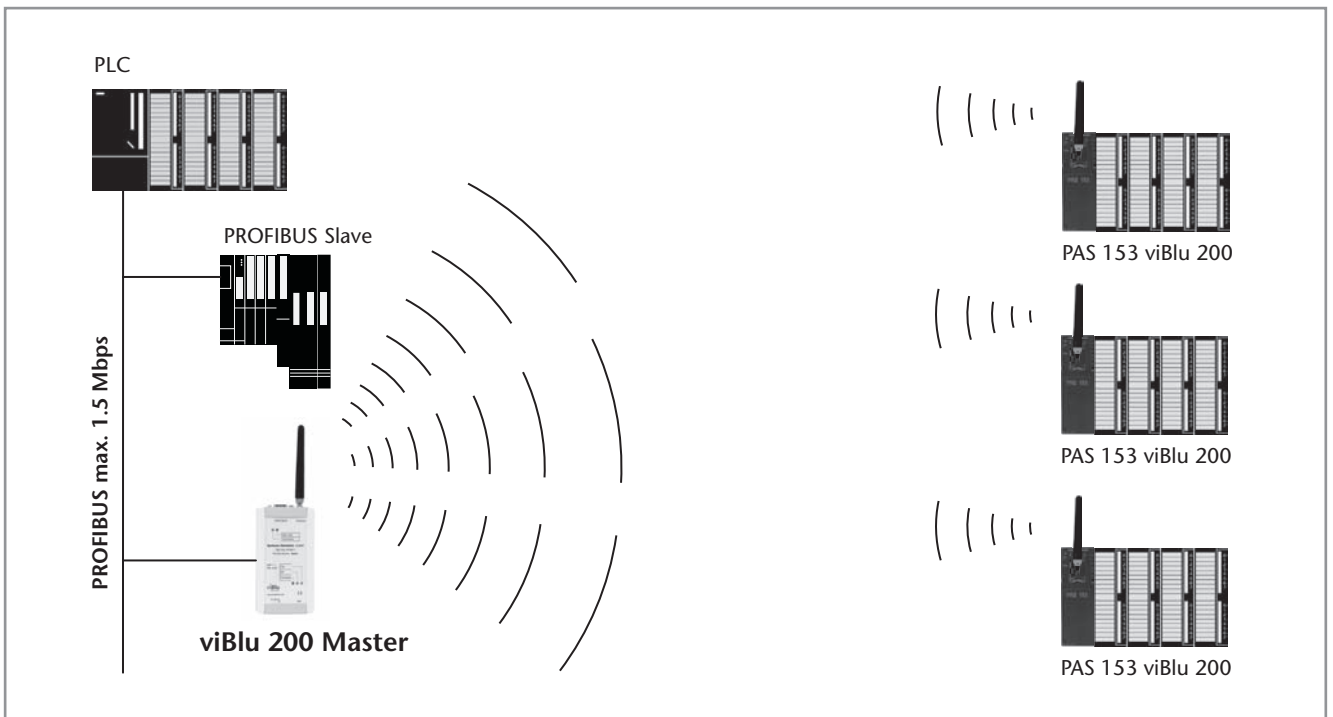

Application example PAS 153 viBlu 200 with 3 Slaves

Antennas for NETLink® WLAN and viBlu



5 dBi magnetic base antenna



Panel 8 dBi antenna

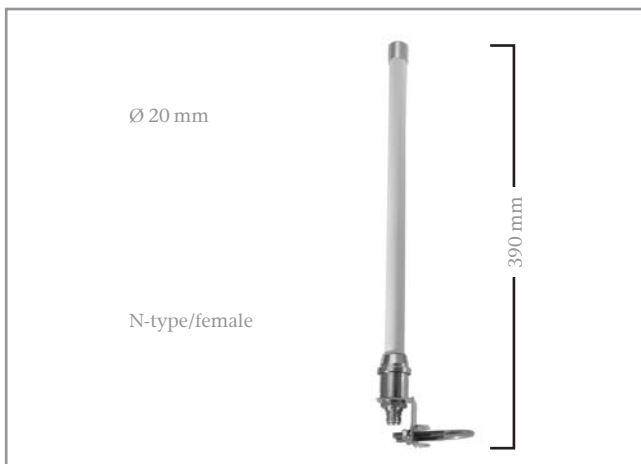

Omni 8 dBi antenna, including wallclamp

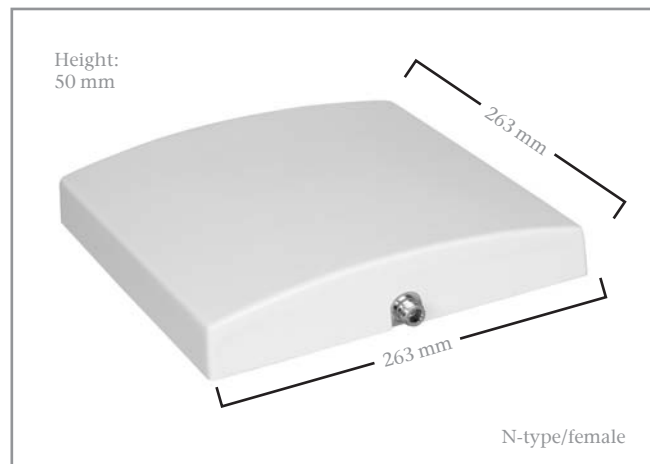

Panel 18 dBi antenna

To optimize the reception power of the NETLink® WLAN and the PROFIBUS radio system viBlu, Systeme Helmholtz GmbH can provide a selection of different antennas. Depending on the design, connecting cables can be procured to match. When planning a radio link, it is important always to note that, both in a mobile and in a stationary installations, the range is to some degree influenced by obstacles and the surrounding structures. Due to the max. transmission power of 100 mW in the 2.4 GHz band, radio links of 10 to 30 meters can be implemented in buildings. Outdoors, 100 to 300 meters can be considered realistic for an unobstructed radio link. With a directed panel antenna, more than 300 meters are possible in optimum conditions.

Magnetic base antenna 5 dBi

For mounting on smooth magnetic surfaces. The permanently mounted 1.5 meter long connecting cable further increases the radius of action. The magnetic base can be unscrewed. In this way, the dipole can also be directly operated on the WLAN module and is especially suitable for unobstructed mid-distance links. The omnidirectional antenna can also be correctly aligned with the integrated knee-joint.

Omnidirectional antenna 8 dBi

This omniantenna protected by the stable GFK conduit is supplied with mounting brackets to be able to mount it on masts or walls – preferably outdoors. To obtain the best omnidirectional emission properties, there should be no metallic surfaces or obstructions near to the emitting antenna. A cable, available as an accessory, is required for a type N connection.

Panel antenna 8 dBi (wall mounting) and panel antenna 18 dBi (mast mounting)

Ideal for use in directional transmission and reception indoors and outdoors. The range and WLAN performance are considerably improved by this design. The appropriate fixtures are supplied. A cable, available as an accessory, is required for a type N connection.

Ordering Data	Order No.
2.4 GHz 5 dBi magnetic base antenna, with 1.5 m antenna cable	700-889-ANT01
2.4 GHz Omni 8 dBi antenna (antenna cable required)	700-889-ANT02
2.4 GHz Panel 8 dBi antenna (antenna cable required)	700-889-ANT03
2.4 GHz Panel 18 dBi antenna (antenna cable required)	700-889-ANT04
2.4 GHz antenna cable, 3 m; 1.7 dB; Ø 5 mm	700-889-ANK01
2.4 GHz antenna cable, 5 m; 2.8 dB; Ø 5 mm	700-889-ANK02
2.4 GHz antenna cable, 6 m; 1.4 dB; Ø 10.3 mm	700-889-ANK03
2.4 GHz antenna cable, 10 m; 2.3 dB; Ø 10.3 mm	700-889-ANK04



PAS 153, distributed PROFIBUS Interface

The PAS 153 distributed PROFIBUS Interface from Systeme Helmholtz GmbH is for linking digital and analog input and output modules to the PROFIBUS-DP. The module can be mounted on a sectional rail.

Up to 16 modules can be connected to the PAS 153. The PAS 153 is integrated into the hardware configurer of the programming system by a GSD file. The PAS 153 Interface performs all communication between the modular I/O device and the higher-level master unit on the PROFIBUS-DP. The inputs and outputs are assigned to the master in the configuration. Diagnostic information from the modules can be read out via the PAS 153 Interface in the usual way.

The PAS 153 Interface supports all input/output modules from Systeme Helmholtz GmbH and numerous modules of the same type from other manufacturers.

The scope of modules supported can be extended at any time by a firmware update via the USB.

Features

- DIP switch for setting the PROFIBUS address
- Up to 16 modules can be plugged in
- Module diagnostics supported
- Can be used on standard sectional rail
- Any combination of modules is possible (analog/digital)
- PROFIBUS-DP up to 12 Mbps
- GSD file is supplied
- Firmware update for expanding functions possible via USB

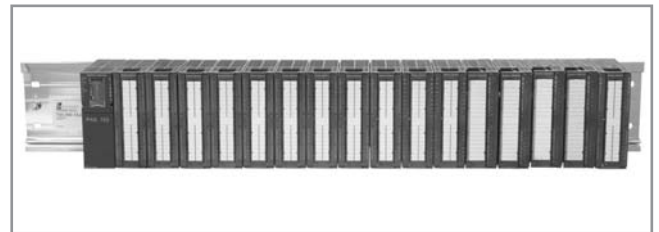

Up to 16 modules can be plugged in



Ordering Data	Order No.
PAS 153, distributed PROFIBUS Interface (incl. CD with GSD file)	700-153-1AA03
Manual PAS 153, German/English	900-153-1AA03

Technical Data	
Dimensions (D x W x H mm)	116 x 40 x 125
Weight	Approx. 250 g
Power supply	
Voltage	DC 24 V
Current consumption	max. 625 mA
Output voltage	DC 5 V
Output current at DC 5 V	max. 1.5 A (to backplane)
PROFIBUS Interface	
Transmission rate	max. 12 Mbps, autodetection
Protocol	PROFIBUS-DP to EN 50 170
Addressrange	128 Bytes for inputs 128 Bytes for outputs
Module count	max. 16.8 of these analog
Connection	Male, SUB-D, 9-way
Ambient temperature	0 °C ... +60 °C
Transport and storage temperature	-25 °C ... +60 °C

DP/DP Coupler



DP/DP Coupler

The DP/DP coupler interlinks two PROFIBUS-DP networks and permits data transmission between the masters and the two DP networks. The maximum size of the transmitted data is 244 Bytes of input data and 244 Bytes of output data. The DP/DP coupler is configured in the S7 software or by means of a GSD file.

Features

- Up to 244 Bytes of input data and 244 Bytes of output data can be exchanged between two PROFIBUS networks
- Dual-redundant power supply
- Electrical isolation between the PROFIBUS networks
- PROFIBUS addresses can be set by DIL switch or software
- PROFIBUS-DP up to 12 Mbps



Technical Data	
Dimensions (D x W x H mm)	116 x 40 x 125
Weight	Approx. 250 g
Power Supply Nominal power supply Current consumption	24 V DC (20.4 V... 28.8 V) Approx. 150 mA at DC 24 V
Electric isolation of the 24 V power supply To PROFIBUS-DP	Yes
Mutually	Yes
PROFIBUS interface Transmission rate	9.6 ... 12 Mbps
Protocol	PROFIBUS-DP
Telegram length I/O data	Max. 244 Bytes inputs/ 244 Bytes outputs
Ambient temperature	0 °C ... 60 °C
Degree of protection	IP 20

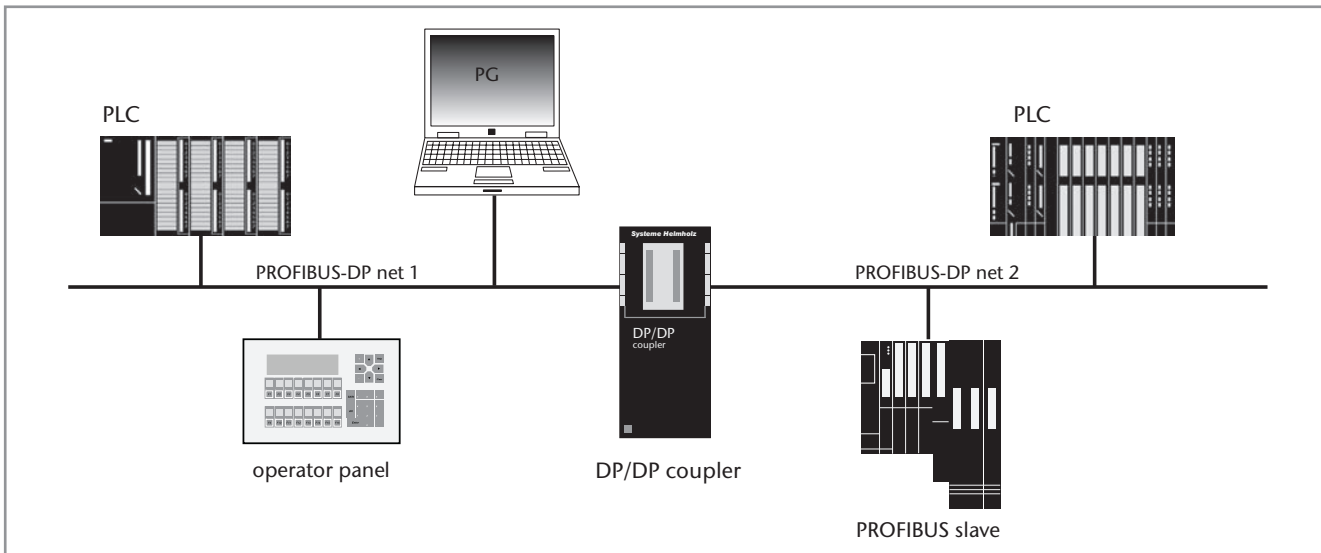

Application example DP/DP Coupler

Ordering Data	Order No.
DP/DP Coupler (incl. manual)	700-158-0AD01
Mounting rail adapter for DIN rail (optional)	700-390-6BA01



FLEXtra® profiPoint, active Termination and Measuring Point

Features

- Power supply independent of bus stations
- Bus termination independent of terminal device due to autonomous power supply
- Can be used as an active measuring point
- Supply to active PROFIBUS components (Compact Repeater, NETLink®, PROFIBUS diagnostic connector)



FLEXtra profiPoint

The FLEXtra® profiPoint from Systeme Helmholtz GmbH is primarily used for supplying power to the terminating resistor and is designed for mounting on a DIN rail. It can be used in combination with a PROFIBUS connector as an active measuring point or as an active termination. The electric power is supplied independently of the bus stations via a connection socket.

If used as an active terminating resistor, bus system stations can be coupled and decoupled randomly without faults occurring. The correct function of the FLEXtra® profiPoint can be read from an integrated LED. A PROFIBUS connector is required for connection to the PROFIBUS cable (also available as a set).

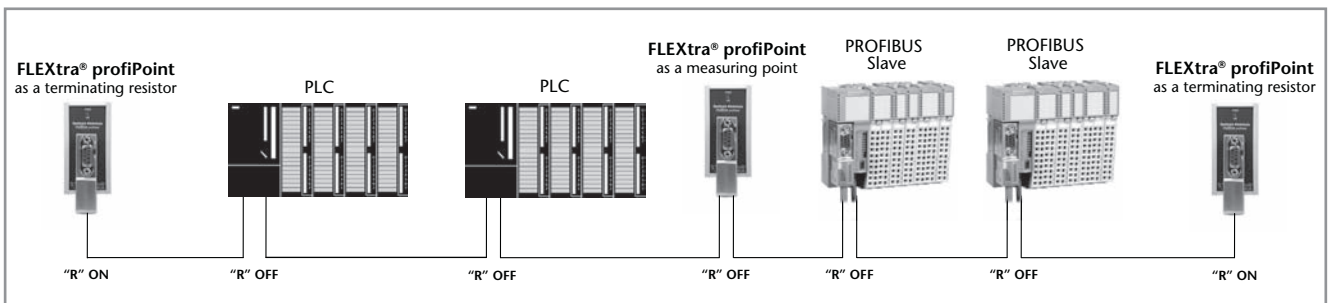

Application example FLEXtra® profiPoint

Ordering Data	Order No.
FLEXtra® profiPoint (incl. instruction)	700-972-1AA02
FLEXtra® profiPoint Set FLEXtra® profiPoint, PROFIBUS connector screw terminals 90° diagnostic LEDs with PG (incl. instruction)	700-972-1XA02

Technical Data	
Dimensions (D x W x H mm)	35 x 32 x 72
Weight	Approx. 85 g
Power supply	18 ... 30 VDC
Output voltage	24 VDC/5 VDC
Potential separation	500 V
Current consumption	max. 400 mA
Segment connection	Via PROFIBUS connector
Ambient temperature	0 °C ... +60 °C
Transport and storage temperature	-25 °C ... +75 °C
Degree of protection	IP 20

Active PROFIBUS Dropcable, PROFIBUS cable assembled



Active PROFIBUS dropcable for PG

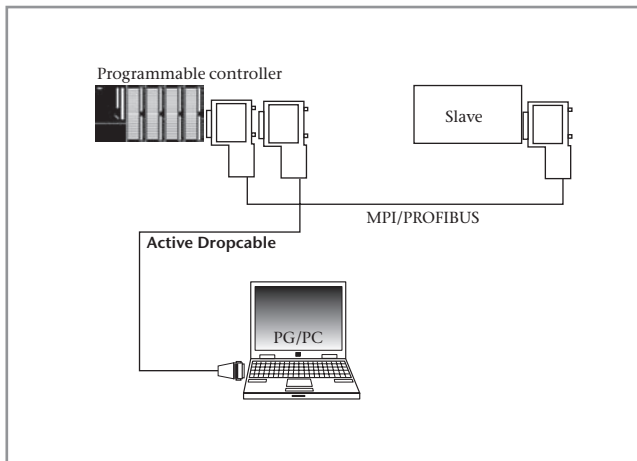

Application example Active Dropcable

The active PROFIBUS dropcable from the Systeme Helmholtz GmbH is used for a failure-free connection of a programming device to an existing PROFIBUS net. The active cable doesn't represent a spur line because of its integrated electronics.

Technical Data	
Dimensions (length)	3 m
Weight	Approx. 260 g
Power supply	DC 5 V
Current consumption	max. 100 mA at 5V
PROFIBUS interface	
Transmission	max. 12 Mbps
Connection	SUB-D, 9-way
Ambient temperature	0 °C ... +60 °C
Transport and storage temperature	-25 °C ... +75 °C
Degree of protection	IP 20

Ordering Data	Order No.
Active PROFIBUS Dropcable for PG with 90° PROFIBUS connector, 3 m (incl. instruction)	700-901-4BD00
Active PROFIBUS Dropcable for PG with 35° PROFIBUS connector, 3 m (incl. instruction)	700-901-4BD10



PROFIBUS cable assembled, 1 m

Ordering Data	Order No.
PROFIBUS cable assembled (flexible) 2 x PROFIBUS connector 90° without PG	
1 m	700-970-1VK01
2 m	700-970-1VK02
3 m	700-970-1VK03
5 m	700-970-1VK05
10 m	700-970-1VK10
PROFIBUS cable assembled (flexible) 2 x PROFIBUS connector 90° with PG	
1 m	700-970-2VK01
2 m	700-970-2VK02
3 m	700-970-2VK03
5 m	700-970-2VK05
10 m	700-970-2VK10

This product is available on request.

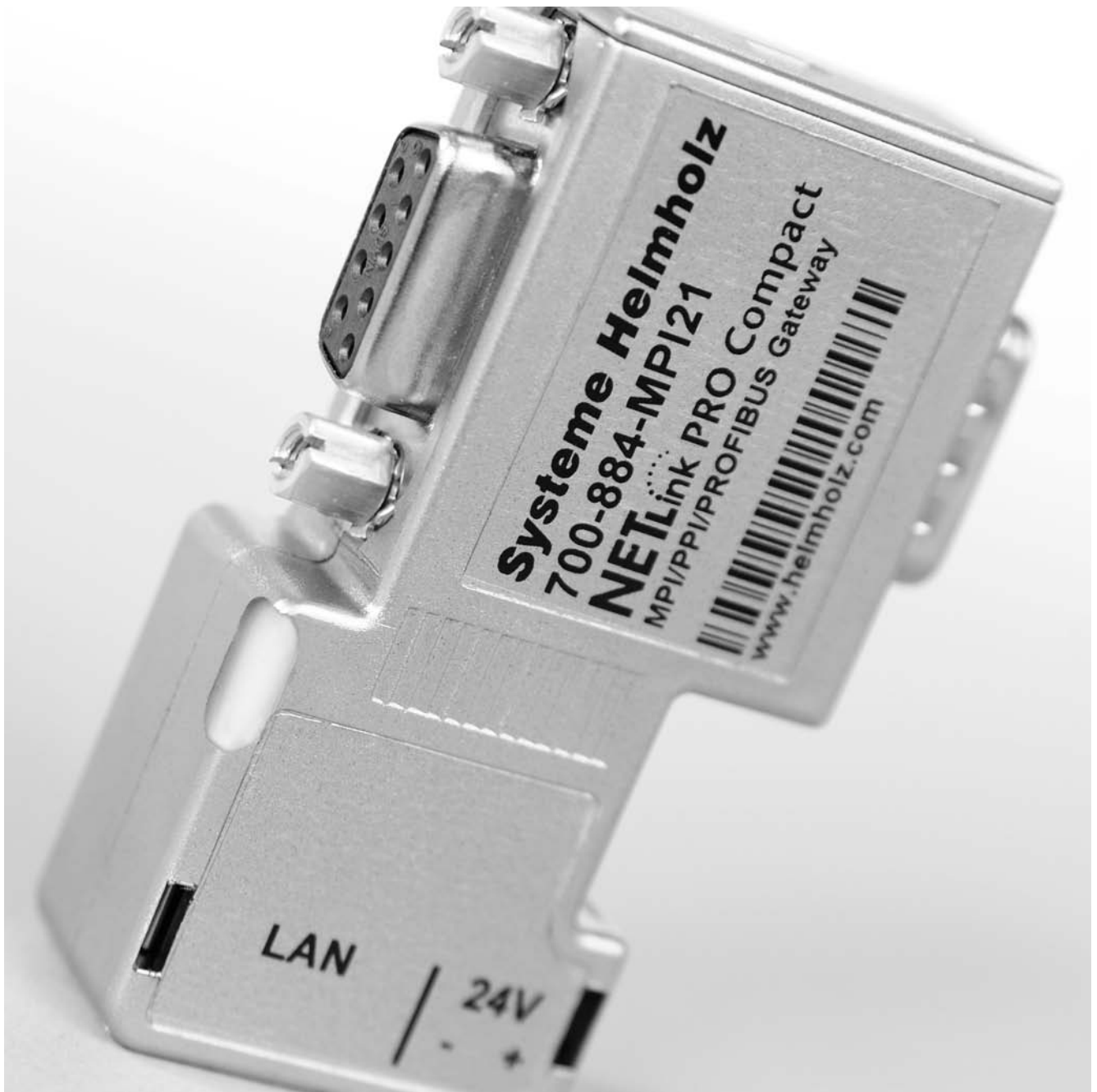

NETLink® Gateways

Ethernet Gateways

WLAN Gateways

Highspeed USB Gateways

for MPI/PPI/PROFIBUS

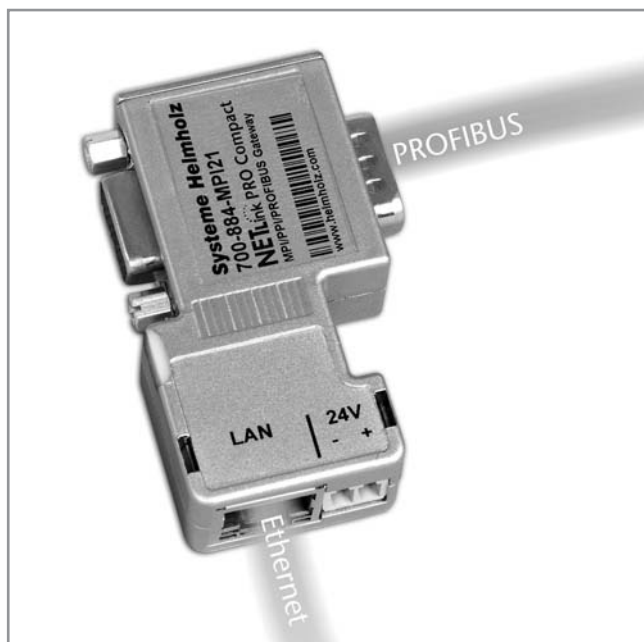

NETLink® PRO Compact, PROFIBUS-Ethernet Gateway

• Now with more diagnostic functions in the web interface

The NETLink® PRO Compact offers flexibility, compact design and even more application benefits. Power is supplied via the CPU of the automation unit or optionally by an external 24 V DC power unit. The network interface can be used with every standard Cat-5 cable, thus, cable lengths up to 100 meters are possible without any further components.

Generally, a connection to every MPI/PROFIBUS interface of the bus system is possible. A direct connection to the interfaces of active or passive bus devices is also feasible. The connector casing has an integrated PG socket, which permits connection of further devices. NETLink® PRO Compact permits conversion from TCP/IP to MPI/PPI/PROFIBUS with a maximum of 32 simultaneous links, and supports the communication to passive participants by activating the switchable Single-Master function. The integration of SCADA, HMI, and OPC applications can be realized via the widely used ISO on TCP (RFC1006) protocol, and NETLink® PRO Compact detects and forwards those requests automatically. The integrated web interface offers now even more parameterization, diagnostics and security features. Additional future functions can be updated independently by the user at any time. For this purpose, we provide our diagnostic software SHTools for free. The latest version is available for download on our web page www.helmholz.com.

Ordering Data	Order No.
NETLink® PRO Compact (incl. 3 m Ethernet cable, Quick Start Guide, CD with software and manual)	700-884-MPI21
Manual NETLink® Ethernet Products, German/English	900-88X-MPI21

1) S7-200, S7-300 and S7-400 are registered trademarks of Siemens AG.

Features

- RFC 1006 (ISO on TCP)
- CPU-to-CPU communication
- Power supply from the CPU or alternatively via external 24 V DC
- Support for all common S7 Engineering Tools
- Dynamic address assignment with DHCP
- Security functions for securing TCP/IP access
- Additional CPU write protection
- For S7-200¹⁾, S7-300¹⁾, S7-400¹⁾
- Up to 16 TCP connections
- Up to 32 links on MPI/PROFIBUS
- Simple configuration via the web interface
- Variable monitoring in the browser window
- Support of slave parameterization
- Electrical isolation to the MPI/PPI/PROFIBUS
- MPI/PPI/PROFIBUS from 9.6 kbps up to 12 Mbps

NETLink PRO Compact

Technical Data	
Dimensions (D x W x H mm)	64 x 40 x 17
Weight	Approx. 110 g
Power Supply	
Voltage	DC 24 V ±25%
Current consumption max.	200 mA
Communication interface	
Type	10 Base-T 100 Base-TX
Connector	RJ45
Transmission rate	10/100 Mbps, autodetection
MPI/PPI/PROFIBUS	
Type	RS485, isolated
Transmission rate max.	12 Mbps, autodetection
Connector	SUB-D, 9-way with PG interface and repeater
Protocols	FDL frames, RFC 1006
Ambient temperature	0 °C ... 60 °C
Indicators	2 LEDs, therefrom one three coloured (for general status information)
Degree of protection	IP 20

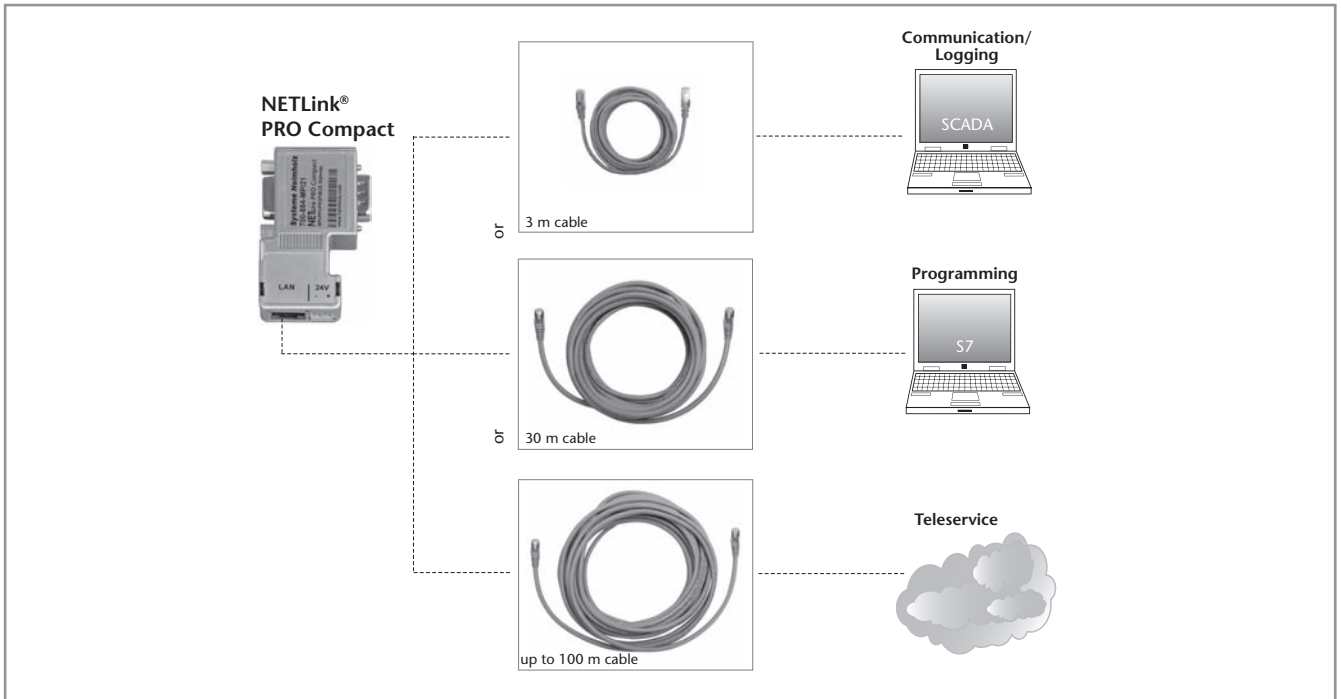

Application example NETLink® PRO Compact

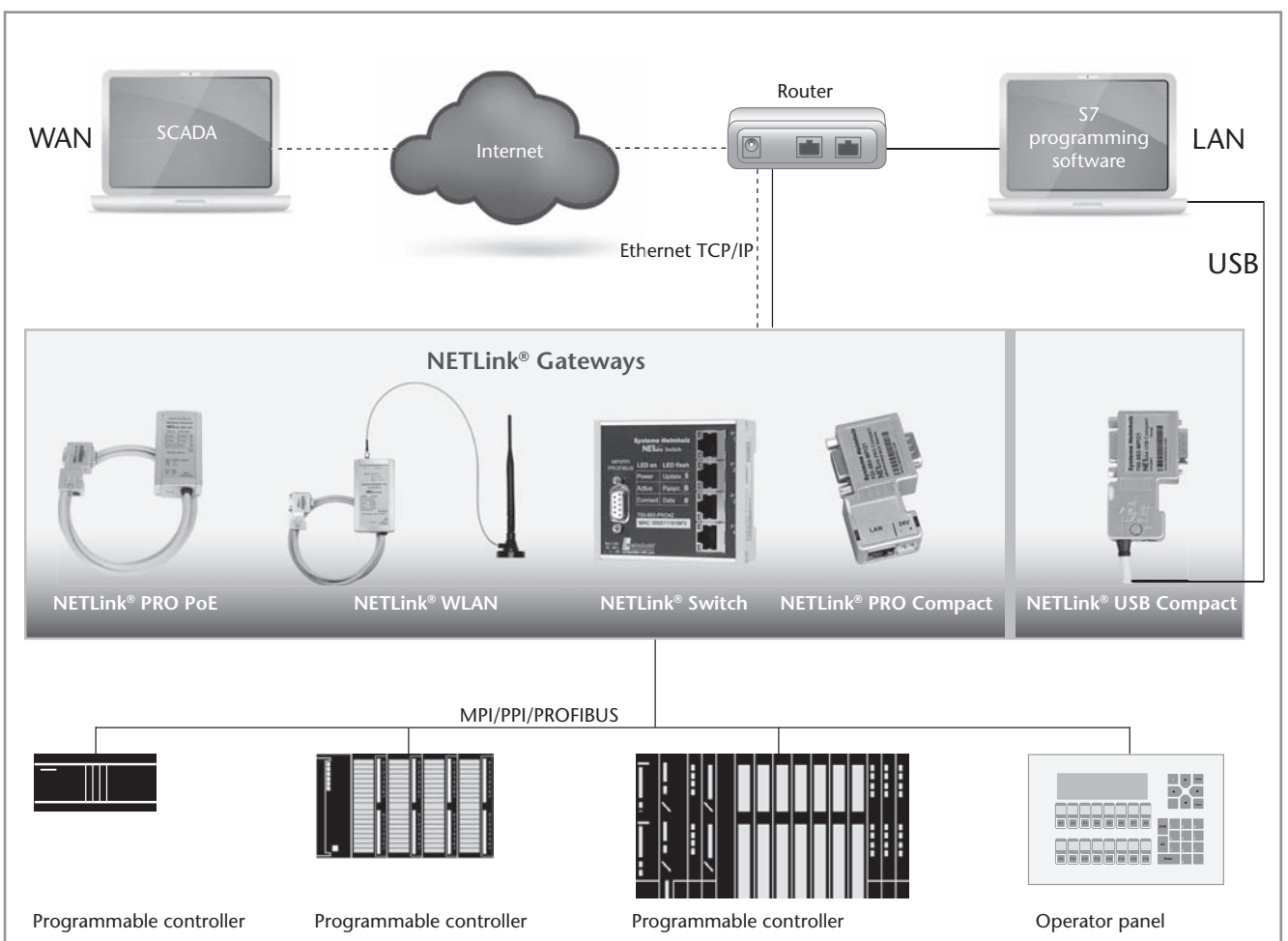

Application Example LAN-WAN connection via ISO on TCP



NETLink® PRO PoE, PROFIBUS Ethernet Gateway

• Now available with Power over Ethernet

NETLink® PRO PoE for programming, configuring and visualization of S7 PLCs obtains the power via the CPU interface of the automation unit or optionally by an external 24V DC power unit or via the CAT5 Network-cable with the help of an PoE energy supply unit. The 1.2 meter connecting cable is an active cable and therefore it does not influence any other installed participants in the bus system.

Generally, a connection to every MPI/PROFIBUS interface of the bus system is possible. A direct connection to the interfaces of active or passive bus devices is also feasible. The connector casing has an integrated PG socket, which permits connection of further devices. NETLink® PRO PoE permits conversion from TCP/IP to MPI/PPI/PROFIBUS with a maximum of 32 simultaneous links, and supports the communication to passive participants by activating the switchable Single-Master function. The integration of SCADA, HMI, and OPC applications can be realized via the widely used ISO on TCP (RFC1006) protocol, and NETLink® PRO PoE detects and forwards those requests automatically. The integrated web interface offers now even more parameterization, diagnostics and security features. Additional future functions can be updated independently by the user at any time. For this purpose, we provide our diagnostic software SHTools for free. The latest version is available for download on our web page www.helmholz.com.

Ordering Data	Order No.
NETLink® PRO PoE (incl. 3 m Ethernet cable, Quick Start Guide, CD with software and manual)	700-881-MPI21
NETLink® PRO PoE, 35° cable outlet for S7-400 ¹⁾ (incl. 3 m Ethernet cable, Quick Start Guide, CD with software and manual)	700-881-MPI22
DIN rail adapter short Power Plug (optional)	700-751-HSH01 700-751-SNT01
Manual NETLink® Ethernet Products, German/English	900-88X-MPI21

1) S7-200, S7-300 and S7-400 are registered trademarks of Siemens AG.

Features

- RFC 1006 (ISO on TCP)
- CPU-to-CPU communication
- Powered Device (PD) according to the IEEE Standards 802.3af (POE) and IEEE 802.3at (POE+)
- Support for all common S7 Engineering Tools
- Dynamic address assignment with DHCP
- Security functions for securing TCP/IP access
- Additional CPU write protection
- For S7-200¹⁾, S7-300¹⁾, S7-400¹⁾
- Up to 16 TCP connections
- Up to 32 links on MPI/PROFIBUS
- Simple configuration via the web interface
- Variable monitoring in the browser window
- Support of slave parameterization
- Electrical isolation to the MPI/PPI/PROFIBUS
- MPI/PPI/PROFIBUS from 9.6 kbps up to 12 Mbps

NETLink PRO PoE

Technical Data	
Dimensions (D x W x H mm)	102 x 54 x 30
Weight	Approx. 180 g
Power Supply	
Voltage	DC 24 V ±25 %
Voltage PoE	48 V according to IEEE 802.3af/at
PoE power class	Class 1 (0.44 to 3.84 Watt)
PoE+	Type 1 (see 802.3af)
Current consumption	max. 150 mA
Communication interface	
Type	10 Base-T 100 Base-TX
Connector	RJ45
Transmission rate	10/100 Mbps, autodetection
MPI/PPI/PROFIBUS	
Type	RS485, isolated
Transmission rate	max. 12 Mbps, autodetection
Connector	SUB-D, 9-way with PG interface and repeater
Protocols	FDL frames, RFC 1006
Ambient temperature	0 °C ... 60 °C
Indicators	3 LEDs, therefrom 2 two coloured
Degree of protection	IP 20



NETLink® Switch, Ethernet Gateway with integrated 4-port Switch

• Programming – Visualization – data acquisition and switching over Ethernet

The NETLink® Switch is an Ethernet Gateway with integrated Switch for mounting on a DIN rail bracket. Either it is integrated in the bus with a standard PROFIBUS connector, or plugged directly with an active drop cable on the MPI/PPI or PROFIBUS interface of the bus subscribers. The NETLink® Switch is supplied with an external 24 V DC power source. Besides the function as a programming adapter, the 4port 10Base-TX Switch can be used to integrate additional Ethernet subscribers.

Generally, a connection to every MPI/PROFIBUS interface of the bus system is possible. A direct connection to the interfaces of active or passive bus devices is also feasible. NETLink® Switch permits conversion from TCP/IP to MPI/PPI/PROFIBUS with a maximum of 32 simultaneous links, and supports the communication to passive participants by activating the switchable Single-Master function. The integration of SCADA, HMI, and OPC applications can be realized via the widely used ISO on TCP (RFC1006) protocol, and NETLink® Switch detects and forwards those requests automatically. The integrated web interface offers now even more parameterization, diagnostics and security features. Additional future functions can be updated independently by the user at any time. For this purpose, we provide our diagnostic software SHTools for free. The latest version is available for download on our web page www.helmholz.com.

Ordering Data	Order No.
NETLink® Switch (incl. 3 m Ethernet cable, Quick Start Guide, CD with software and manual)	700-883-PRO42
Manual NETLink® Ethernet Products, German/English	900-88X-MPI21

1) S7-200, S7-300, S7-400 and Simatic are registered trademarks of Siemens AG.

Features

- RFC 1006 (ISO on TCP)
- CPU-to-CPU communication
- Integrated 4 port store-and-forward switch
- Support for all common S7 Engineering Tools
- Dynamic address assignment with DHCP
- Security functions for securing TCP/IP access
- Additional CPU write protection
- For S7-200¹⁾, S7-300¹⁾, S7-400¹⁾
- Up to 16 TCP connections
- Up to 32 links on MPI/PROFIBUS
- Simple configuration via the web interface
- Clear diagnostic page in the web interface
- Variable monitoring in the browser window
- Support of slave parameterization
- Electrical isolation to the MPI/PPI/PROFIBUS
- MPI/PPI/PROFIBUS from 9.6 kbps up to 12 Mbps

NETLink Switch

Technical Data	
Dimensions (D x W x H mm)	35 x 83 x 72
Weight	Approx. 180 g
Power Supply	
Voltage	DC 24 V
Current consumption	approx. 120 mA
Communication interfaces	
Type	10 Base-T 100 Base-TX
Connectors	RJ45
Transmission rate	10/100 Mbps, autodetection
Switch	
Ports	4
Features	Autonegotiation, Autoplunk, Flow Control, MDI/MDI-X Auto Crossover, Spanning Tree
Switching method	Store and forward
MPI/PPI/PROFIBUS	
Type	RS485, isolated
Transmission rate	max. 12 Mbps, autodetection
Connector	SUB-D, 9-way
Protocols	FDL frames, RFC 1006
Ambient temperature	0 °C ... 60 °C
Indicators	3 LEDs, therefrom 2 two coloured
Degree of protection	IP 20



NETLink® WLAN, PROFIBUS Ethernet WLAN Gateway

• Flexible wireless programming using Ad Hoc or Infrastructure mode

The NETLink® WLAN is an Ethernet Gateway with integrated WLAN (Wi-Fi) interface. Alternatively to the RJ45 socket, the „ad hoc“ or „infrastructure“ mode can be parameterized via the web interface. All standard Wireless Security methods such as: WEP, WPA and WPA2 are supported. Power is supplied via the CPU of the automation unit or optionally by an external 24 V DC power pack. The 1.2 meter connecting cable is an active cable and therefore it does not influence any other installed participants in the bus system.

Generally, a connection to every MPI/PROFIBUS interface of the bus system is possible. A direct connection to the interfaces of active or passive bus devices is also feasible. The connector casing has an integrated PG socket, which permits connection of further devices. NETLink® WLAN permits conversion from TCP/IP to MPI/PPI/PROFIBUS with a maximum of 32 simultaneous links, and supports the communication to passive participants by activating the switchable Single-Master function. The integration of SCADA, HMI, and OPC applications can be realized via the widely used ISO on TCP (RFC1006) protocol, and NETLink® WLAN detects and forwards those requests automatically. The integrated web interface offers now even more parameterization, diagnostics and security features. Additional future functions can be updated independently by the user at any time. For this purpose, we provide our diagnostic software SHTools for free. The latest version is available for download on our web page www.helmholz.com.

Ordering Data	Order No.
NETLink® WLAN (incl. 3 m Ethernet cable, Quick Start Guide, CD with software and manual)	700-882-MPI21
DIN rail adapter long Power Plug (optional)	700-751-HSH10 700-751-SNT01
Manual NETLink® Ethernet Products , German/English	900-88X-MPI21

1) S7-200, S7-300, S7-400 are registered trademarks of Siemens AG.

Features

- RFC 1006 (ISO on TCP)
- CPU-to-CPU communication
- Shiftable WLAN interface (802.11 b/g) with up to 54 Mbps
- Support for all common S7 Engineering Tools
- Dynamic address assignment with DHCP
- Security functions for securing TCP/IP access
- Additional CPU write protection
- For S7-200¹⁾, S7-300¹⁾, S7-400¹⁾
- Up to 16 TCP connections
- Up to 32 links on MPI/PROFIBUS
- Simple configuration via the web interface
- Clear diagnostic page in the web interface
- Variable monitoring in the browser window
- Support of slave parameterization
- Electrical isolation to the MPI/PPI/PROFIBUS
- MPI/PPI/PROFIBUS from 9.6 kbps up to 12 Mbps

NETLink WLAN

Technical Data	
Dimensions (D x W x H mm)	130 x 68 x 30
Weight	Approx. 280 g
Power Supply	
Voltage	DC 24 V ±25 %
Current consumption typ.	200 mA
Communication interface	
Type	10 Base-T 100 Base-TX
Connector	RJ45
Transmission rate	10/100 Mbps, autodetection
WLAN Specifications	
Type	IEEE 802.11b; 802.11g
Frequency Range	2.412 - 2.484 GHz
Output Power	14 dBm + 1.5 dBm/-1.0 dBm
Data Rates	54 Mbps
Security	WEP, WPA, WPA2
MPI/PPI/PROFIBUS	
Type	RS485, isolated
Transmission rate max.	12 Mbps, autodetection
Connector	SUB-D, 9-way with PG interface and repeater
Protocols	FDL frames, RFC 1006
Ambient temperature	0°C ... 60°C
Indicators	5 LEDs, therefrom 2 two coloured
Degree of protection	IP 20



5 dBi magnetic base antenna



Panel 8 dBi antenna

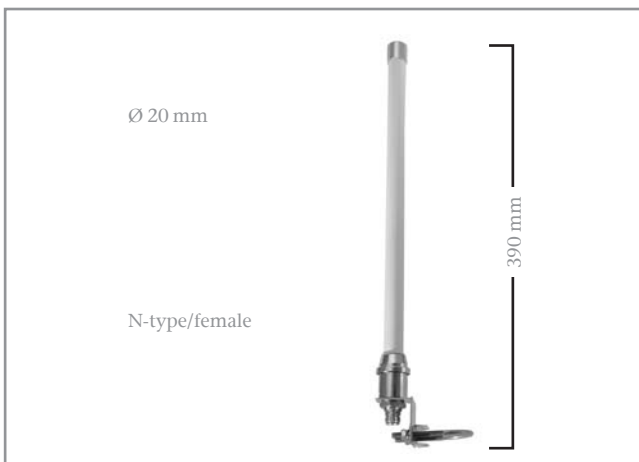

Omni 8 dBi antenna, including wallclamp

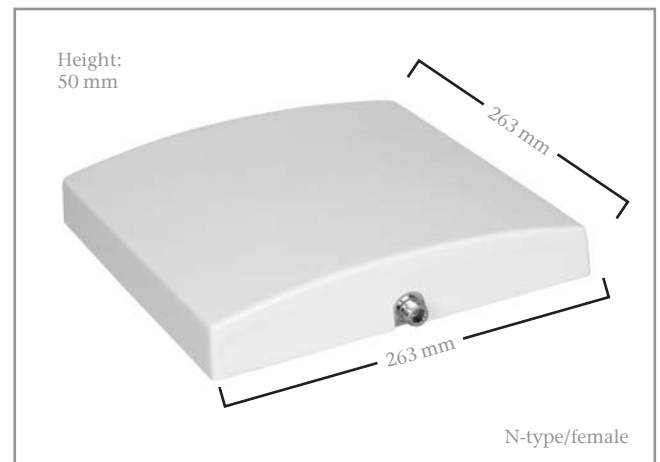

Panel 18 dBi antenna

To optimize the reception power of the NETLink® WLAN and the PROFIBUS radio system viBlu, Systeme Helmholtz GmbH can provide a selection of different antennas. Depending on the design, connecting cables can be procured to match. When planning a radio link, it is important always to note that, both in a mobile and in a stationary installations, the range is to some degree influenced by obstacles and the surrounding structures. Due to the max. transmission power of 100 mW in the 2.4 GHz band, radio links of 10 to 30 meters can be implemented in buildings. Outdoors, 100 to 300 meters can be considered realistic for an unobstructed radio link. With a directed panel antenna, more than 300 meters are possible in optimum conditions.

Magnetic base antenna 5 dBi

For mounting on smooth magnetic surfaces. The permanently mounted 1.5 meter long connecting cable further increases the radius of action. The magnetic base can be unscrewed. In this way, the dipole can also be directly operated on the WLAN module and is especially suitable for unobstructed mid-distance links. The omnidirectional antenna can also be correctly aligned with the integrated knee-joint.

Omnidirectional antenna 8 dBi

This omni antenna protected by the stable GFK conduit is supplied with mounting brackets to be able to mount it on masts or walls – preferably outdoors. To obtain the best omnidirectional emission properties, there should be no metallic surfaces or obstructions near to the emitting antenna. A cable, available as an accessory, is required for a type N connection.

Panel antenna 8 dBi (wall mounting) and panel antenna 18 dBi (mast mounting)

Ideal for use in directional transmission and reception indoors and outdoors. The range and WLAN performance are considerably improved by this design. The appropriate fixtures are supplied. A cable, available as an accessory, is required for a type N connection.

Ordering Data	Order No.
2.4 GHz 5 dBi magnetic base antenna, with 1.5 m antenna cable	700-889-ANT01
2.4 GHz Omni 8 dBi antenna (antenna cable required)	700-889-ANT02
2.4 GHz Panel 8 dBi antenna (antenna cable required)	700-889-ANT03
2.4 GHz Panel 18 dBi antenna (antenna cable required)	700-889-ANT04
2.4 GHz antenna cable, 3 m; 1.7 dB; Ø 5 mm	700-889-ANK01
2.4 GHz antenna cable, 5 m; 2.8 dB; Ø 5 mm	700-889-ANK02
2.4 GHz antenna cable, 6 m; 1.4 dB; Ø 10.3 mm	700-889-ANK03
2.4 GHz antenna cable, 10 m; 2.3 dB; Ø 10.3 mm	700-889-ANK04

What is CPU-to-CPU communication?

You can use S7 basic communication in order to implement a CPU-to-CPU connection. MPI and PROFIBUS connections to all S7-300¹⁾ and 400¹⁾ series PLCs are supported. The firmware used in Siemens CPUs comes with system functions (SFCs) that are used to transfer data between two stations. All Systeme Helmholz GmbH NETLink® Ethernet gateways support the S7 X_PUT and X_GET mechanisms (used to read data from and write data to a communications partner device outside the local S7 station). The popular RFC 1006 transport protocol (ISO over TCP) is used for this type of client-server communications, making it possible to use, among other devices, CPs and PROFINET CPUs that support the protocol as clients.

Connections are not preconfigured, but are instead explicitly established when an SFC call is made. This ensures that a connection resource for communications will only be assigned permanently on the “active” side. The “passive” side, on the other hand, will simply respond to the requests sent by the active station, and will only assign a corresponding resource when the active station establishes a connection.

The practical advantage of this approach is that function calls only need to be stored on the active side (server).

If a user wants to expand an already programmed X_PUT/X_GET to use TCP/IP, it will only be necessary to add an additional X_PUT (with the parameters for the remote station – see the left figure) to the program sequence in order to open the communications channel via a NETLink® Ethernet gateway.

The maximum amount of payload data that can be transmitted in each communication job is limited by the system to 76 bytes. Systeme Helmholz GmbH has created a series of simple sample projects showing how to use the STEP¹⁾ 7 programming software package in order to help both experienced and new users program the solutions they need. All these sample projects are available free of charge, and the corresponding application description

makes it possible to implement CPU-to-CPU communications in only a few steps.

Ethernet CPU/CP to MPI/PROFIBUS

All NETLink® Ethernet gateways have now been upgraded to support asynchronous data exchange with the Siemens SFB14 (“GET”) and SFB15 (“PUT”) communication blocks. These system function blocks are included in Siemens CPUs and will route read and write tasks through the NETLink® adapter connected to the MPI or PROFIBUS interface on a remote CPU. For this type of CPU-to-CPU communications, the network cable can be connected directly to an Ethernet CPU/CP with a NETLink® device. The corresponding non-specific S7 connection, meanwhile, is assigned in NetPro Configuration with the help of a computer station. Systeme Helmholz GmbH also has an application description and a simple sample project available for this type of application. Moreover, the original documentation provided by Siemens includes a general functional description.

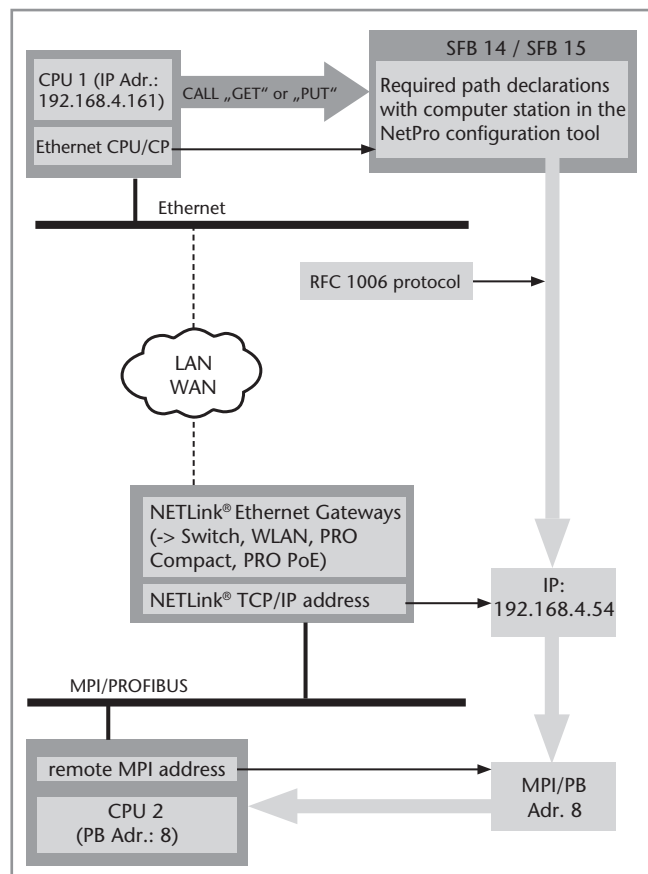
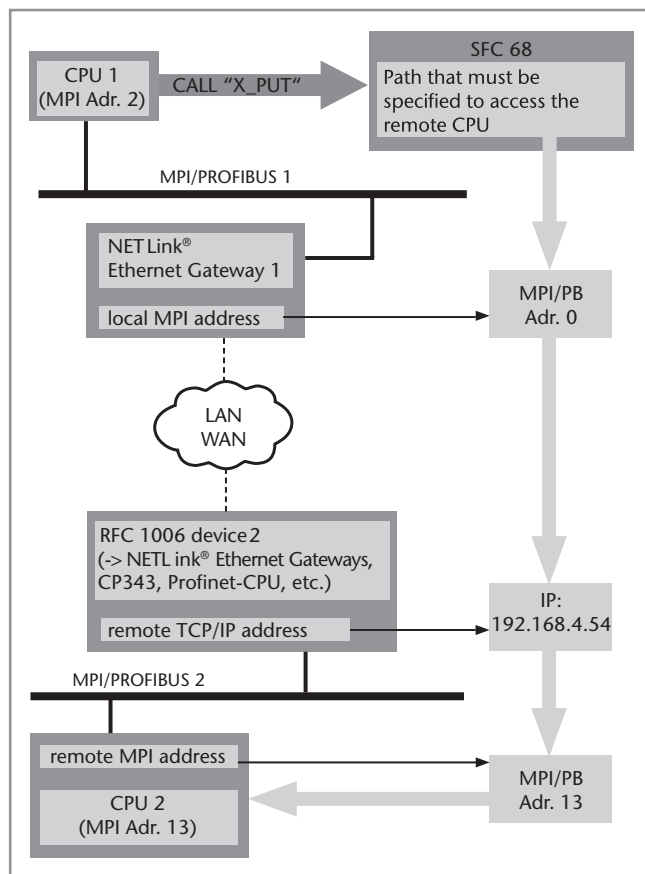

1) S7-200, S7-300, S7-400, Simatic and STEP are registered trademarks of Siemens AG.



NETLink® USB Compact, mini PROFIBUS USB Gateway

• The mobile plug and play programming adapter

NETLink® USB Compact offers flexibility and compact design with the advantages of plug and play via USB. It may be connected to any MPI/PROFIBUS interface of the bus system. The second PG socket permits connection of further devices. The connection with the PC is established using the integrated 3 m high-speed USB cable.

The NETLink® USB Compact is supplied with power from the USB bus. At the USB end, the protocols Fullspeed (12 Mbps) and Highspeed (480 Mbps) are supported. The NETLink® USB Compact permits conversion of a USB interface to MPI/PROFIBUS for programming or visualization with the full transmission rate of up to 12 Mbps with max. 32 simultaneous links.

Baud rate is detected automatically and a Single-Master function enables the communication with passive participants. The supplied driver automatically embeds in the S7 Engineering Tools. The MPI/PROFIBUS is electrically isolated from the USB interface (functional isolation). Furthermore, you can perform diagnostics and configurations with the supplied SHTools software.

A free download of the latest SHTools version is available on our website www.helmholz.com. Thus, additional functions can be updated at any time by yourself.

Ordering Data	Order No.
NETLink® USB Compact (incl. Quick Start Guide, CD with software and manual)	700-892-MPI21
Manual NETLink® USB Compact, German/English	900-892-MPI21

1) S7-200, S7-300 and S7-400 are registered trademarks of Siemens AG.

Features

- Support for all common S7 Engineering Tools
- For S7-200¹⁾, S7-300¹⁾, S7-400¹⁾
- Up to 32 links on MPI/PROFIBUS
- Support of slave parameterization
- Electrical isolation to the MPI/PPI/PROFIBUS
- MPI/PPI/PROFIBUS from 9.6 kbps up to 12 Mbps
- USB 2.0 up to 480 Mbps (Highspeed)
- No separate power supply required
- With programming device connector (PG) as standard

NETLink USB Compact

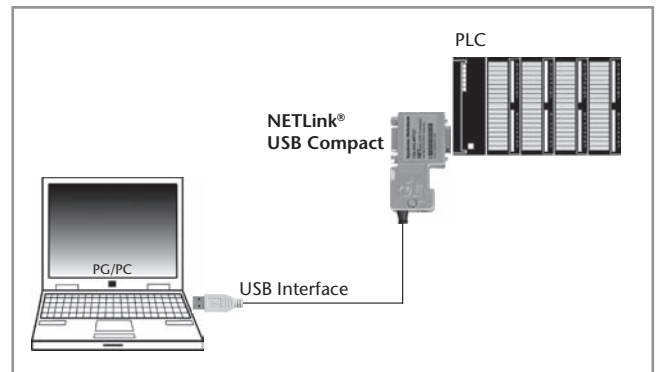

Application Example NETLink® USB Compact

Technical Data	
Dimensions (D x W x H mm)	64x 40 x 17
Weight	Approx. 115 g
Power Supply	
Voltage	DC 5 V USB
Current consumption	typ. 200 mA at DC 5 V USB
Communication interface	
Type	USB 2.0
Connector	USB-A-female connector
Transmission rate	12 Mbps Fullspeed/ 480 Mbps Highspeed
MPI/PPI/PROFIBUS	
Type	RS485, isolated
Transmission rate	max. 12 Mbps, autodetection
Connector	SUB-D, 9-way with PG interface
Protocols	FDL frames
Ambient temperature	0 °C ... 60 °C
Indicators	2 LEDs, therefrom one three coloured (for general status information)
Degree of protection	IP 20

Quick access to S7 and S5 data with 32-bit and 64-bit computer architectures

The number of operating systems supported by S7/S5 OPC Server version 4.10 and higher has been expanded, making it possible to quickly and conveniently access the process data on your PLCs. After a straightforward installation process on a computer with a Windows operating system (XP/2003/Vista/2008/7), you will have access to a standardized OPC interface for exchanging data with a number of controllers, including the following: S7 200¹⁾/300¹⁾/400¹⁾ series, LOGO! 0BA7, WinAC¹⁾, C7, and S5 U-series CPUs.

This will enable any OPC-compliant client application to read and write any required input/output data, data blocks, flags, timers, and counters from and to S7/S5 controllers. Variable addressing is based on S7's well-established addressing syntax, and can be imported directly from an Excel file or an S7 project if necessary. Existing control programs in your PLC do not need to be modified for communications with an S7/S5 OPC server, meaning that detailed knowledge of the PLC program being executed is not required.

Flexible connection

A variety of options, such as TCP/IP, PROFIBUS, MPI, PPI, and AS511, are available for connecting your controllers to an S7/S5 OPC server. Up to 16 communication devices can be activated in the S7/S5 OPC server configuration menu, making parallel data exchange processing possible. Moreover, up to 256 controllers can be accessed simultaneously with the TCP/IP communications protocol (RFC 1006), provided the maximum number of expansion modules is being used. Systeme Helmholz GmbH has the following communications adapters available:

- All REX 300 and NETLink[®] family products
- SSW7, SSW7-TS, SSW7-USB for MPI
- SSW3, SSW4, and SSW5 for AS511

Selected communication modules from other manufacturers, such as Siemens CPs 243, 343, and 443, are also supported. In addition, an improved license management system has been developed in order to optimize the USB drivers included with the hardware dongle so as to allow the use of licenses in virtual machines (VMWare³⁾, ESX³⁾, etc.).

Integrated web server

The S7/S5 OPC server features an integrated web server. This web server can be used to diagnose OPC server functions and to provide original control and monitoring webpages on any standard browser.

The web server's architecture and performance have been designed with small-scale visualization interfaces in mind. This version (as well as higher versions) not only supports OPC Data Access 1.0a, 2.05 und 3.0, but also allows non-Windows-based applications to use the S7/S5 OPC server with OPC XML-DA. The latest OPC server version²⁾ is available for download (incl. all technical information) at www.helmholz.com.

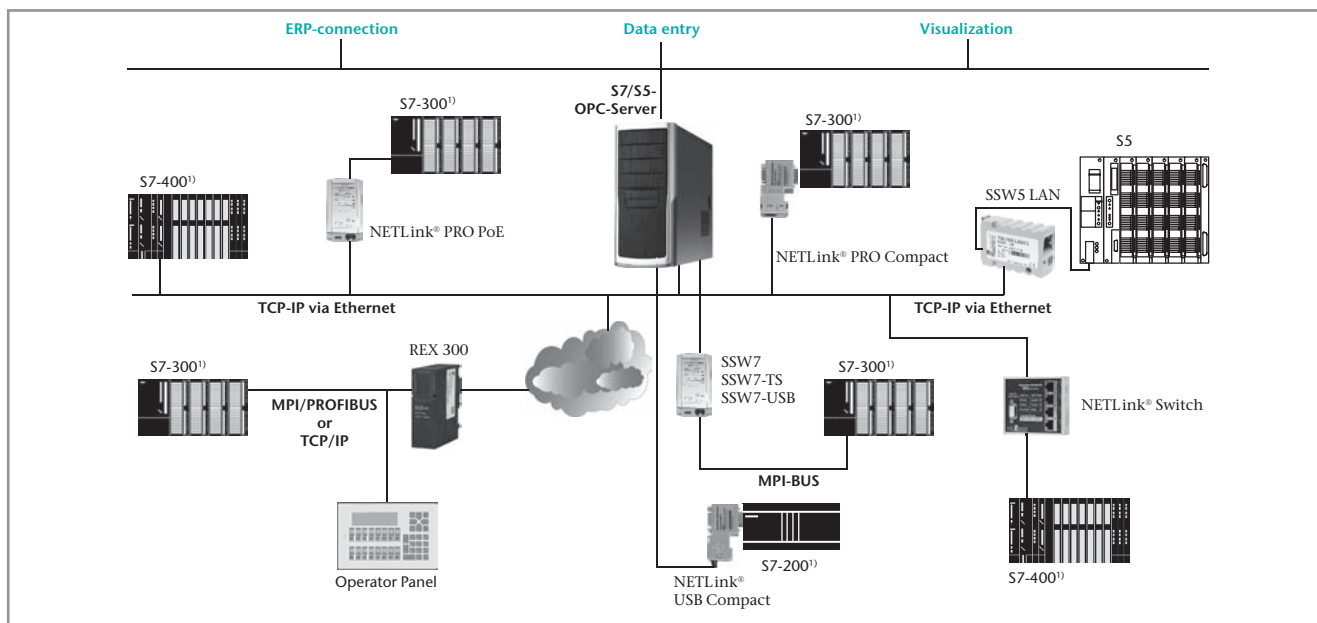
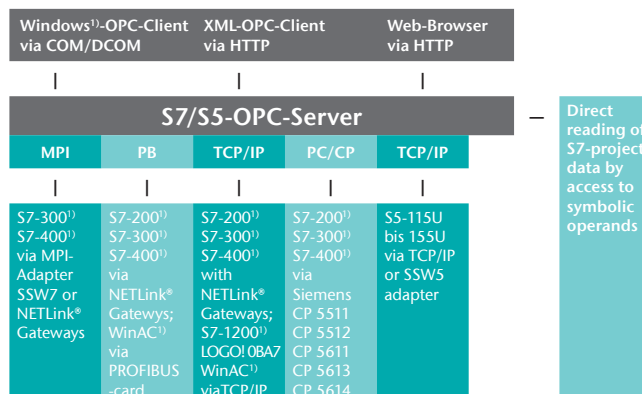

Application example for OPC-Server

1) WinAC, S7-200, S7-300, S7-400, S7-1200, and WinCC are registered trademarks of Siemens AG. Windows is a registered trademark of Microsoft Corporation.
 2) Without a USB hardware dongle license, the full version can only be used for 90 minutes in demo mode.
 3) VMWare and ESX are registered trademarks of VMware, Inc.

Ordering Data	Order No.
S7-OPC-Server with USB-Dongle	800-880-OPC41



Teleservice

Ethernet Router
Mediation server
Modems
Adapter for Teleservice
Teleservicemodule



REX 300, Ethernet Router

The REX 300 industrial router provides you with maximum flexibility and greatest possible security. With the router, you can remotely establish simple and secure communication with your plants.

Due to its S7-300¹⁾ design, the REX 300 can easily be integrated into an S7-300¹⁾ system and, with the included PG/PC interface driver, it can be used within all common Simatic¹⁾ Engineering Tools.

The REX 300 is easy to configure via its web user interface. Irrespective of the way the connection with the internet is established (analog, ISDN, UMTS or DSL), the integrated, application-oriented configuration wizard makes configuration of the VPN, internet, and network connection easier.

It permits ready-to-use configuration within a matter of minutes. The free my-REX services of Systeme Helmholz GmbH make it easier to access the router via the internet with dynamic name resolution or by sending e-mails from the assigned IP address of the internet provider.

Because of the additional serial interface, in versions with a WAN connection (except REX 300 eco), it is also possible to include serial devices in the remote maintenance.

VPN portal myREX24

Using the myREX24 mediation server, you bypass the time-consuming firewall pass-through authorisations or service requests for your customer or mobile telecom operator. The setting up is simplified enormously because one outgoing connection is established in each case from the point of view of the system or user. The connections are established via VPN whereby their data are transmitted encrypted.

Your benefits

- Access requestable at www.myREX24.net
- Software for easily establishing a connection
- Set up configurations in myREX24
- Configurations can be downloaded
- Full control over active connections, achieved with comprehensive status info
- User and permissions management system
- SMS triggering with shSMS
- Reports on every single connection that is established
- WEB2go makes it possible to keep an eye on your equipment at all times while on the go with a smartphone or tablet computer

Features

- Secure remote servicing via OpenVPN/IPSec¹⁾/PPTP¹⁾
- Integrated firewall
- I/O manager for reading and archiving a maximum of 256 PLC variables³⁾
- Fallback management for managing multiple Internet ports³⁾
- Service Ethernet devices remotely via Internet
- Directly connect S7-MPI/PROFIBUS devices¹⁾
- Free S7-MPI/PROFIBUS drivers
- Service RS-232/RS-485³⁾ devices remotely via Internet¹⁾
- USB port for firmware updates²⁾ and setting up configurations³⁾
- A plugged-in USB stick can be shared on the network³⁾
- Configuration Wizard for easy setup

(antennas and cable extension available as accessories)

1) Depends on the specific model

2) Firmware updates should be applied using the REX 300 web interface so that configuration settings will be retained

3) Only devices with order number suffix -02

Accessory-Note

For GSM antennas, see page 60. To connect serial devices to the REX 300 with WAN connection, an adapter cable for the serial interface is required (see Ordering Data).

Ordering Data	Order No.
REX 300	
VPN, analog (incl. telephone cable, Ethernet cable, Quick Start Guide)	700-871-MDM01
VPN, EDGE (incl. Ethernet cable, Quick Start Guide)	700-871-EDG01
VPN + WAN, analog + serial interface (incl. telephone cable, Ethernet cable, Quick Start Guide)	700-872-MDM01
VPN + WAN, EDGE + serial interface (incl. Ethernet cable, Quick Start Guide)	700-872-EDG02
VPN + WAN, UMTS + serial interface (incl. Ethernet cable, Quick Start Guide)	700-872-UMT02
VPN + WAN + serial interface, without Modem (incl. Ethernet cable, Quick Start Guide)	700-873-WAN02
REX 300 eco, VPN+WAN, without MPI interface, without Modem (incl. Ethernet cable, Quick Start Guide)	700-874-WAN02
REX 300 eco, VPN+UMTS, without MPI interface (incl. Ethernet cable, Quick Start Guide)	700-874-UMT02
Adapter cable serial interface (RS232) , for REX 300, 3 m, 9-way male connector	700-879-1VK11
Adapter cable serial interface (RS485) , for REX 300, 3 m, 9-way male connector	700-879-1VK21
Mounting rail adapter for DIN rail (optional)	700-390-6BA01
Manual REX 300, German	900-87x-REX300

1) S7-300 and S7-400 are registered trademarks of Siemens AG.

REX 300 industrial router version overview:

Order No.	VPN	LAN	WAN	analog	ISDN	EDGE	UMTS	MPI/ PROFIBUS	COM serial	USB
700-871-MDM01	x	x		x				x		
700-871-EDG01	x	x				x		x		
700-872-MDM01	x	x	x	x				x	x	
700-872-EDG02	x	x	x			x		x	x	x
700-872-UMT02	x	x	x			x	x	x	x	x
700-873-WAN02	x	x	x					x	x	x
700-874-WAN02	x	x	x							x
700-874-UMT02	x	x				x	x			x

Technical Data	
Dimensions (D x W x H mm)	116 x 40 x 124 mm
Weight	Approx. 300 g
Modem	Analog/ISDN/ GSM (GPRS/EDGE)
Router Functions	Dial In, Dial Out, call-back function, DHCP server and client, firewall, DynDNS, NAT/PAT, SMS control
VPN	IPSec, PPTP, OpenVPN
Authentication PPP VPN	PAP, CHAP PSK, X.509 certificates
Encryption (VPN)	AES, DES/3DES
Ports LAN/WAN	100 Mbps for full and half-duplex operation, automatic detection, autosensing
MPI/PROFIBUS Serial	RS485 - 9,6 kbps to 12 Mbps RS232, RS485 (2- and 4-wire), RS422
Configuration Web interface	Local/remote
Power supply Voltage Current consumption	10 VDC ... 30 VDC Max. 250 mA
Ambient temperature	0 °C ... +60 °C
Degree of protection	IP 20

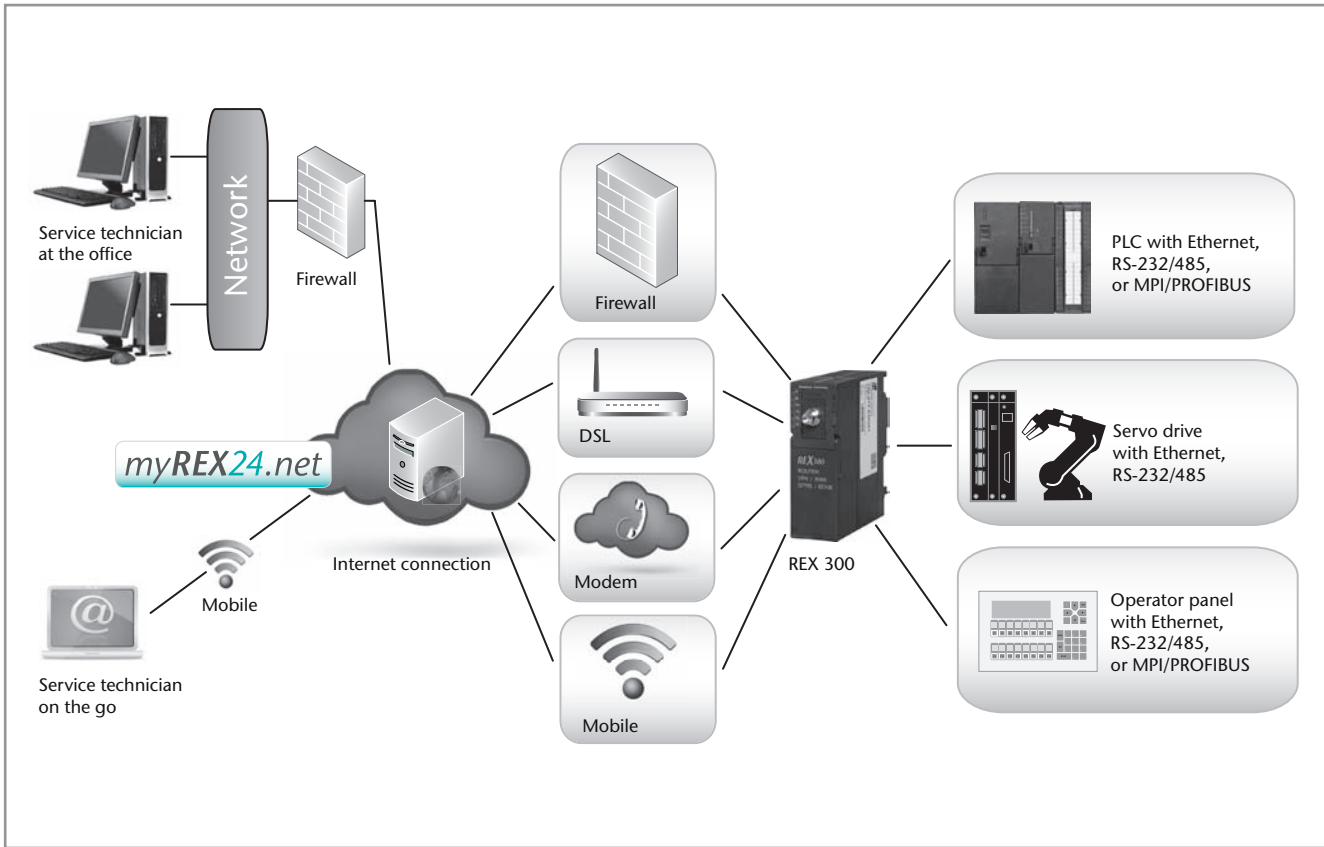

Possible connections to REX 300

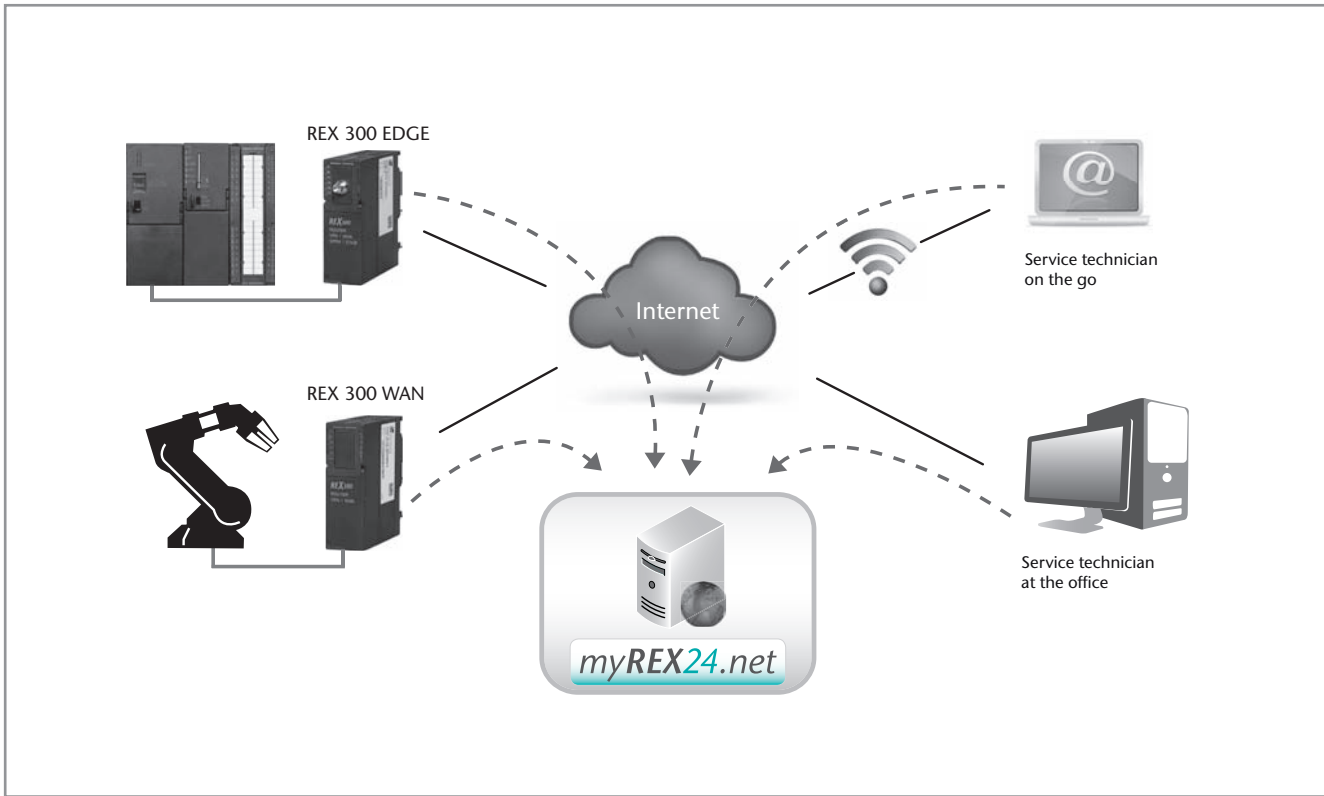

Application with myREX24

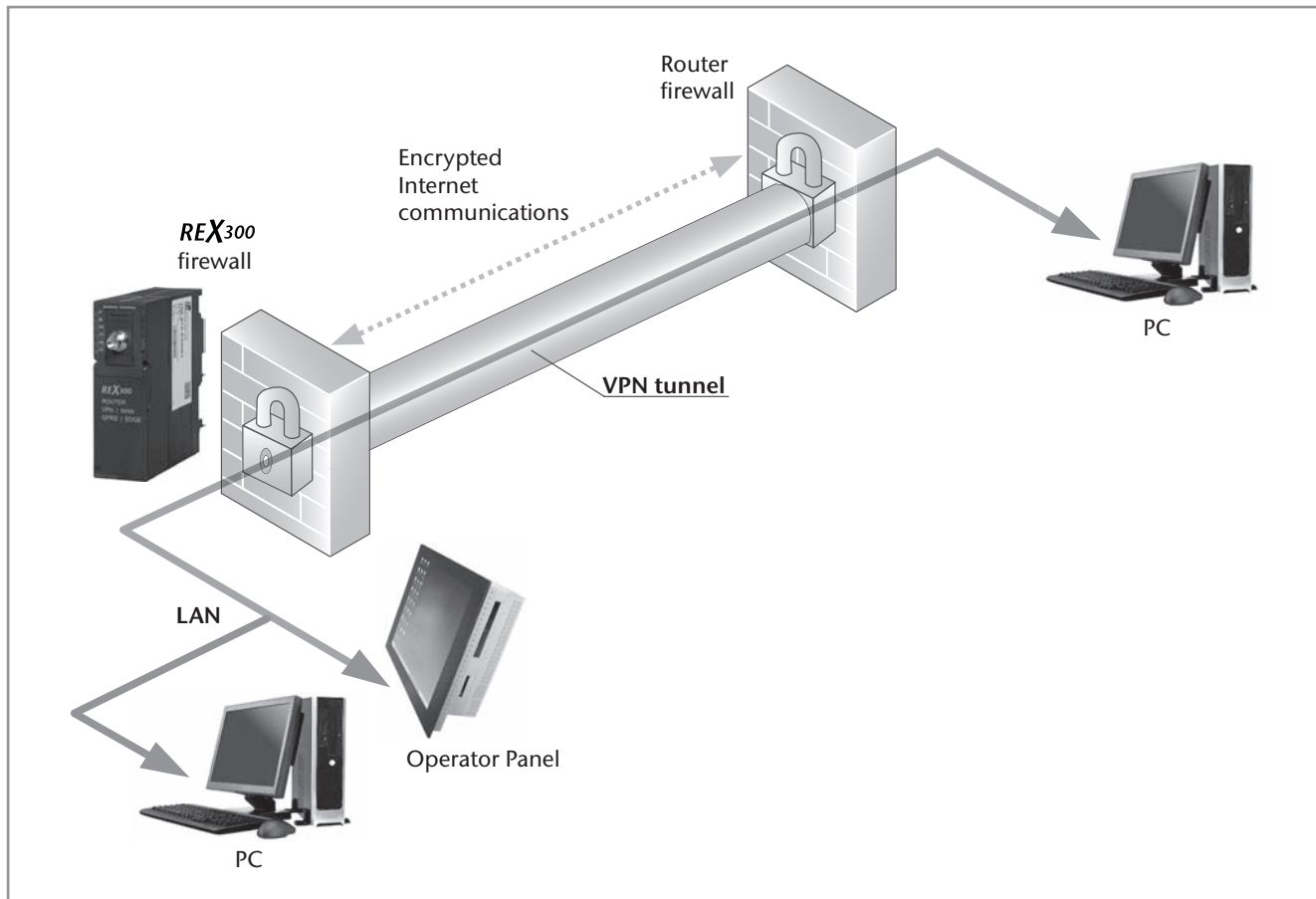

Application example REX 300 with VPN



myREX24.net ordering data	Order No.
myREX24.net basic Access account for myREX24.net with one free active* connection and one WEB2go connection, plus the option of creating ten REX 300 devices and using 10 SMS messages for free. <ul style="list-style-type: none"> • Number of users allowed: 250 • Number of user groups allowed: 250 • Number of devices allowed: 250 (additional charges apply starting with the 11th device) • Number of device groups allowed: 250 • Number of active connections allowed: 1 (additional charges apply starting with the 2nd active connection) 	
myREX24.net REX 300 One-time fee for each additional REX 300 device.	800-870-REX01
myREX24.net ac1 License for 1 additional active connection*. Duration: 1 year.	800-870-ACT01
myREX24.net ac3 License for 3 additional active connections*. Duration: 1 year.	800-870-ACT03
myREX24.net ac5 License for 5 additional active connections*. Duration: 1 year.	800-870-ACT05
myREX24.net ac10 License for 10 additional active connections*. Duration: 1 year.	800-870-ACT10
myREX24.net WEB1 License for 1 additional WEB2go connection*. Duration: 1 year.	800-870-WEB01
myREX24.net WEB5 License for 5 additional WEB2go connections*. Duration: 1 year.	800-870-WEB05
myREX24.net WEB10 License for 10 additional WEB2go connections*. Duration: 1 year.	800-870-WEB10
myREX24.net WEB20 License for 20 additional WEB2go connections*. Duration: 1 year.	800-870-WEB20
myREX24.net WEB30 License for 30 additional WEB2go connections*. Duration: 1 year.	800-870-WEB30
myREX24.net WEB50 License for 50 additional WEB2go connections*. Duration: 1 year.	800-870-WEB50
myREX24.net shSMS 50 SMS messaging package with 50 messages	800-870-SMS05
myREX24.net shSMS 100 SMS messaging package with 100 messages	800-870-SMS10
myREX24.net shSMS 200 SMS messaging package with 200 messages	800-870-SMS20
myREX24.net shSMS 300 SMS messaging package with 300 messages	800-870-SMS30
myREX24.net shSMS 500 SMS messaging package with 500 messages	800-870-SMS50

*** Active connection**

Active connections are actual connections between a user and a REX 300 device. That means that all users and REX 300 devices can remain permanently connected to myREX24.net connection hub, only when a user actually connects to a **REX 300 device** an active connection is established.



SSW7-TS, MPI Adapter

The SSW7-TS can be used to teleservice your system via a modem connection. For this, you can connect a commercially available external modem (analog, ISDN, GSM) to the RS232-interface of the SSW7-TS. For local use, you simply connect the RS232 interface of the SSW7-TS to your PC. The SSW7-TS automatically detects the baud rate (9.6–115.2 kbaud) used by the PC. At the system end, you can connect the SSW7-TS to an MPI network with 187.5 or 19.2 kbps.

The PC must be installed with the teleservice module for the programming software (e.g. TeleService for Simatic STEP¹ 7) so that the SSW7-TS can be parameterized if necessary, and the modem connection maintained. Without modems or the teleservice module the SSW7-TS can be operated at the machine as a SSW7. The voltage supply for the SSW7-TS is taken from the CPU via the MPI bus. With an optional 24 V connection it can be operated anywhere else in the system.

The SSW7-TS can also be provided with a new firmware via a modem connection. Therefore a function upgrade of an adapter already installed in the system is also possible.

Accessory-Note

By using SHTools software parameterization and diagnostic functions are possible. For firmware update a free download of the latest SHTools version is available on our website www.helmholz.com.

Features

- Teleservice via external modem (analog, ISDN, GSM)
- Usable with Hayes compatible modems
- Password protection
- Call-back function
- Online update function
- In-situ use as programming adapter
- MPI up to 187.5 kbps

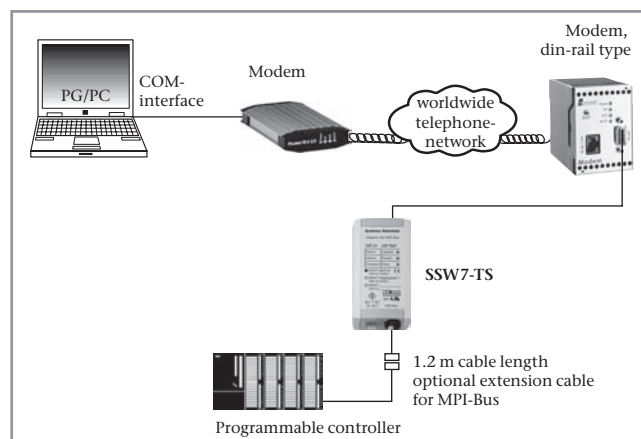

Application example for SSW7-TS

Technical Data	
Dimensions (D x W x H mm)	105 x 53 x 29
Weight	Approx. 180 g
Supply voltage	+24 V ±25 % from PLC or extern
Current consumption	typ. 30 mA max. 45 mA
MPI interface	
Type	RS485
Transmission rate	19.2 or 187.5 kbps
Cable connector	SUB-D, 9-way with PG interface and terminating resistor
Communication interface	
Type	RS232
Transmission type	Serial asynchronous
Transmission rate	9.6 ... 115.2 kbps
Parity	Odd
Data format	8 Bit
Protocols	PC <-> S7 via modem or local
Connection	Connector, SUB-D, 9-way
Degree of protection	IP 20

From STEP¹ 7 version 5.5 SP2 Siemens no longer supports serial COM ports when using Windows 7² 64 bit. The TIA Portal¹ also supports no COM ports - no matter what operating system is installed!

- 1) STEP, Simatic and TIA Portal are registered trademarks of Siemens AG.
- 2) Windows 7 is a registered trademark of Microsoft Corporation.

Ordering Data	Order No.
MPI-Adapter SSW7-TS (incl. manual, CD with software)	700-751-8VK21
DIN rail adapter short Power Plug (optional)	700-751-HSH01 700-751-SNT01

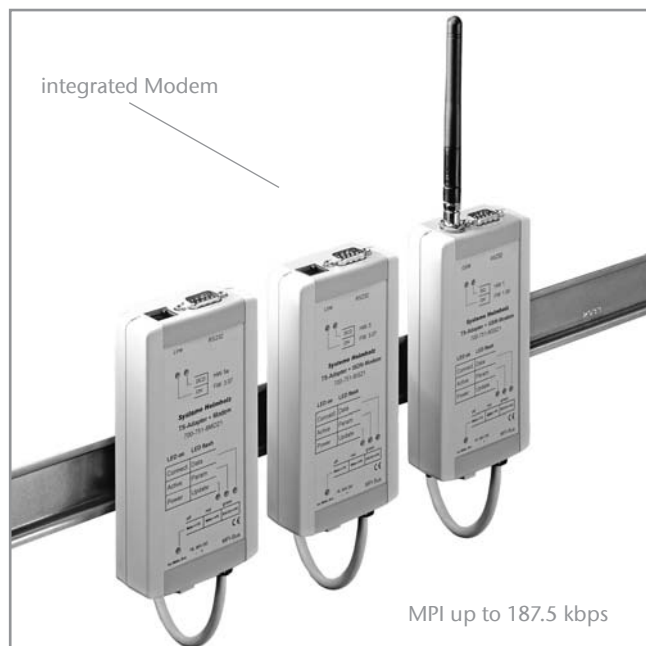

SSW7-TS with Modem

The SSW7-TS with integrated modem is a low-cost alternative for teleservicing a programmable controller via the MPI bus.

Depending on the version, an analog, ISDN, or GSM modem is integrated in the housing of the SSW7-TS. The analog modem can be configured for worldwide use. All connecting cables required for operation are included. The SSW7-TS with a GSM modem (quadband) is the right choice for mobile use or if a telephone connection is not available.

Via the serial interface, the SSW7-TS with modem can also be used as a PC adapter for local use. The modem can be used for teleservicing a VISU/SCADA application even without a TS adapter function. The SSW7-TS with modem receives its power supply from the CPU via the MPI cable or via an external power supply. With the free SHTools software the SSW7-TS with modem can also be updated with new firmware via a modem link.

That enables functional expansion of an adapter already installed in the system.

Accessory-Note

The SSW7-TS with GSM modem requires a mini SIM card with CSD service (Circuit Switched Data) activated and a suitable GSM antenna (see page 60).

Ordering Data	Order No.
MPI-Adapter SSW7-TS with modem analog (incl. DIN rail adapter, 2 x telephone cable RJ11 + TAE each 3 m, 3 m programming cable, manual, CD with software)	700-751-8MD21
SSW7-TS with modem ISDN (incl. DIN rail adapter, RJ11 telephone cable 3 m; 3 m programming cable, manual, CD with software)	700-751-8IS21
SSW7-TS with modem GSM (incl. DIN rail adapter, 3 m programming cable, manual, CD with software) (GSM antennas see page 60)	700-751-8GS21
Power Plug (optional)	700-751-SNT01

Features

- MPI up to 187.5 kbps
- Teleservice and in-situ use
- Password protection and call-back function
- RS232-interface
- Online update function
- DIN rail adapter for mounting included in scope of supply

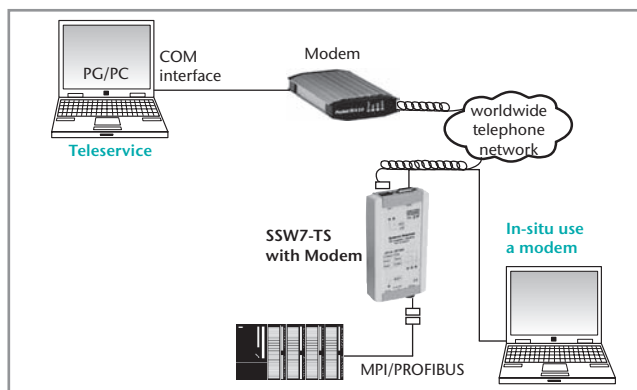

Application example for SSW7-TS with Modem analog

Technical Data	
Dimensions (D x W x H mm)	135 x 67 x 30
Weight	Approx. 240 g
Supply voltage	+24 V \pm 25 % from PLC or extern
Current consumption	Analog/ISDN approx. 100 mA, GSM approx. 150 mA
MPI interface	
Type	RS485
Transmission rate	19.2 or 187.5 kbps
Cable connector	SUB-D, 9-way with PG interface and terminating resistor
Communication interface	
Type	RS232; 2-wire dial-up (analog); ISDN S ₀
GSM-Frequency	Quadband: GSM850, EGSM900, DCS1800, PCS1900
Transmission type	Serial asynchronous
Transmission rate	9.6 ... 115.2 kbps
Protocols	PC \leftrightarrow S7 via modem or local
Connection	Connector, SUB-D, 9-way RJ11 or SIM card slot
Degree of protection	IP 20

From STEP¹⁾ 7 version 5.5 SP2 Siemens no longer supports serial COM ports when using Windows 7²⁾ 64 bit. A parameterization and remote maintenance is no longer possible with the integrated teleservice module in TIA portal¹⁾.

- 1) STEP and TIA Portal are registered trademarks of Siemens AG.
2) Windows 7 is a registered trademark of Microsoft Corporation.

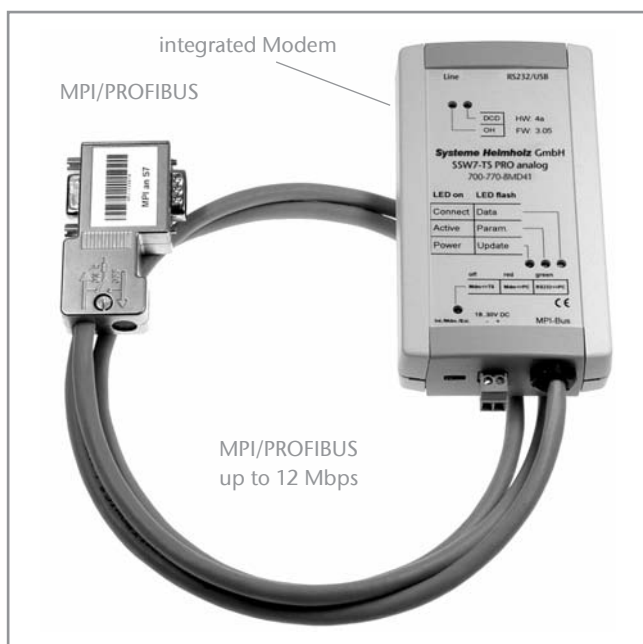

SSW7-TS PRO; analog

The SSW7-TS PRO can be used for teleservicing a S7 system via a modem connection and supports connection of the system to an MPI or PROFIBUS network with up to 12 Mbps.

Depending on the version, an analog, ISDN, or GSM modem is integrated in the housing of the SSW7-TS PRO. The analog modem can be configured for worldwide use. The SSW7-TS PRO GSM is the right choice for mobile use or if a telephone connection is not available.

In addition to use as a remote service solution, the SSW7-TS PRO can also be used locally as a PC adapter via its RS232 or USB interface.

The MPI/PROFIBUS connecting cable of the SSW7-TS PRO is not a spur line because of the repeater integrated into the connector. It allows the adapter to be connected at any point along the bus even at 12 Mbps.

The SSW7-TS PRO draws its power supply via the MPI/PROFIBUS connecting cable or, if necessary, via the external power source. Using the free software SHTools, firmware updates can be transmitted directly and via the modem connection.

As a new feature, the SSW7-TS PRO now also supports transmission of any SMS messages. SMS transmission is triggered by calling the SMS_SEND function block from the programmable controller.

Ordering Data	Order No.
MPI-Adapter SSW7-TS PRO analog (incl. DIN rail adapter, 2 x telephone cable RJ11 + TAE each 3 m, 3 m programming cable, USB cable, manual, CD with software)	700-770-8MD41
SSW7-TS PRO ISDN (incl. DIN rail adapter, RJ11 telephone cable 3 m, 3 m programming cable, USB cable, manual, CD with software)	700-770-8IS41
SSW7-TS PRO GSM (incl. DIN rail adapter, 3 m programming cable, USB cable, manual, CD with software) (GSM antennas see page 60)	700-770-8GS41
Power Plug (optional)	700-751-SNT01

Features

- MPI/PROFIBUS up to 12 Mbps; autobaud
- Teleservice and in-situ use
- Password protection and call-back function
- RS232 and USB interface
- Remote updating possible
- **New feature:** Transmission of any SMS messages from the PLC

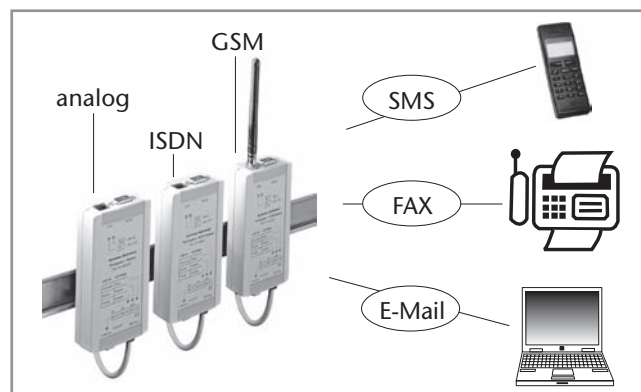

Application example for SSW7-TS PRO analog/ISDN/GSM

Accessory-Note

The SSW7-TS PRO GSM additionally requires a mini SIM card with the CSD service (Circuit Switched Data) activated and a suitable GSM antenna. (see page 60)

Technical Data	
Dimensions (D x W x H mm)	130 x 67 x 30
Weight	Approx. 240 g
Supply voltage	+24 V ±25% from PLC or extern
Current consumption	Approx. 130 mA
MPI interface	
Type	RS485
Transmission rate	9.6 kbps - 12 Mbps
Cable connector	SUB-D, 9-way with PG interface and terminating resistor
Communication interfaces	
Type	RS232; 2-wire dial-up (analog), ISDN S ₀ ; USB
GSM-Frequency	Quadband: GSM850, EGSM900, DCS1800, PCS1900
Transmission type	Serial asynchronous/USB
Transmission rate	9.6 ... 115 kbps
Data format	8 Bit
Protocols	PC <-> S7 via modem or local
Connection	Connector, SUB-D, 9-way RJ11; Mini-USB female connector
Degree of protection	IP 20

From STEP¹⁾ 7 version 5.5 SP2 Siemens no longer supports serial COM ports when using Windows 7²⁾ 64 bit.

When using the TIA portal¹⁾ a parameterization of these products can only be carried out by SHTools. The dial-in and remote control of a programmable controller is then also possible with the TIA Portal¹⁾.

- 1) STEP and TIA Portal are registered trademarks of Siemens AG.
- 2) Windows 7 is a registered trademark of Microsoft Corporation.



TS 300, Teleservicemodule for the PLC-Rack

With the TS 300, teleservice of a system can be performed via the MPI bus.

The TS 300 has a single-width S7-300¹⁾ housing for mounting on the sectional rail. A 56k modem is integrated into the housing of the TS 300 that is prepared for use worldwide. A flash update is no longer necessary. TAE and RJ11 cables are included in the scope of supply. As alternatives, versions with ISDN or GSM modem are also available.

The TS 300 can establish an MPI link with the CPU via the backplane bus. The power supply is also drawn from the backplane bus. Therefore, for installation of a teleservice solution, only the phone line is required.

The TS 300 does not need to be configured in the hardware configuration of the PLC and can therefore be retrofitted at any time. Alternately, the TS 300 can be powered from an external 24 V source. The MPI connection can also be established via the 9-way sub D jack on the front.

An additional USB connection is used to parameterize the TS 300, for in-situ use as a PC adapter, or for direct use of the internal modem.

Features

- MPI up to 187.5 kbps
- TS adapter in the S7 rack for Teleservice
- Analog, ISDN, GSM
- USB interface for parameterization or in-situ use
- Password protection
- Call-back function
- Online update function
- Alert functions and switch outputs usable via back plane bus
- Mode change via Teleservice
- Up to two alarm messages can be transmitted by SMS per module
- Communication via the backplane bus possible³⁾

The TS 300 can also be updated with a new operating system via a remote link. That enables functional expansion of a TS 300 already installed in the system.

By using SHTools software parameterization and diagnostic functions are possible. For firmware update a free download of the latest SHTools version is available on our website www.helmholz.com.

Accessory-Note

For GSM antennas, see page 60.

Ordering Data	Order No.
TS 300 with modem analog (incl. 3 m USB cable, 2 x telephone cable RJ11+TAE each 3m, manual, CD with software)	700-753-8MD21
TS 300 with modem ISDN (incl. 3 m USB cable, 1 x RJ11 telephone cable 3m, manual, CD with software)	700-753-8IS21
TS 300 with modem GSM (incl. 3 m USB cable, manual, CD with software) (GSM antennas see page 60)	700-753-8GS21
MPI-connecting cable, 0.5 m	700-753-6VK11
Mounting rail Adapter for DIN rail (optional)	700-390-6BA01
Mounting rail 40 mm	700-390-1XA04

From STEP¹⁾ 7 version 5.5 SP2 Siemens no longer supports serial COM ports when using Windows 7²⁾ 64 bit.

A parameterization and remote maintenance is no longer possible with the integrated teleservice module in TIA portal¹⁾.

1) S7-300, STEP and TIA portal are registered trademarks of Siemens AG.

2) Windows 7 is a registered trademark of Microsoft Corporation.

3) It is advised against a MPI functionality at the back plane bus when using the following CPUs: S7-315 2 DP/PN, S7-317, S7-318 and S7-319 (State: 11-2011)

Technical Data			
	TS 300 analog	TS 300 ISDN	TS 300 GSM
Degree of protection	IP 20	IP 20	IP 20
Dimensions (D x W x H)	116 x 40 x 124 mm	116 x 40 x 124 mm	116 x 40 x 124 mm
Weight	Approx. 280 g	Approx. 280 g	Approx. 280 g
Operating voltage	DC +24 V \pm 25 %, external or 5 V via backplane bus	DC +24 V \pm 25 %, external or 5 V via backplane bus	DC +24 V \pm 25 %, external
Current consumption	Approx. 500 mA (backplane bus) Approx. 140 mA (external)	Approx. 500 mA (backplane bus) Approx. 140 mA (external)	Approx. 50 mA (backplane bus) Approx. 170 mA (external)
Ambient temperature	0 °C to +60 °C	0 °C to +60 °C	0 °C to +60 °C
MPI interface			
Type	RS485	RS485	RS485
Transmission rate	19.2 or 187.5 kbps	19.2 or 187.5 kbps	19.2 or 187.5 kbps
Connection	SUB-D, 9-way socket or via backplane bus	SUB-D, 9-way socket or via backplane bus	SUB-D, 9-way socket or via backplane bus
USB communication interface			
Type	USB 2.0, USB 1.1 compliant	USB 2.0, USB 1.1 compliant	USB 2.0, USB 1.1 compliant
Connection	USB-B socket for internal modem or TS adapter	USB-B socket for internal modem or TS adapter	USB-B socket for internal modem or TS adapter
Transmission rate	9.6 kbps to 115.2 kbps via virtual COM port	9.6 kbps to 115.2 kbps via virtual COM port	9.6 kbps to 115.2 kbps via virtual COM port
Modem	Analog interface 56 kbps (V.92)	ISDN S0 interface acc. to ITU I.430, 64 kbps	Quadband: GSM850, EGSM900, DCS1800, PCS1900
Modem connection	RJ-11 socket	RJ-11 socket	3 V mini SIM card, FME connector for antenna
SMS transmission	2	2	2
Transmission standards	V.90, V.34+, V.34, V.32bis, V.32, V.22, V.22bis, V.21, V.23, BELL standard 103, 212 Fax Class 1, Fax Class 2	Transmission in D channel at 9,600 bps (X.31-D) Transmission in B channel at 64,000 bps (X.31-B))	Class 4 (2 W) for GSM850/EGSM900 Class 1 (1W) for DCS1800/PCS1900
Protocols		B channel: V.110, X75, X25/X31, HDLC (transparent) D channel: DSS1, X.31	

Antennas for GSM Modems

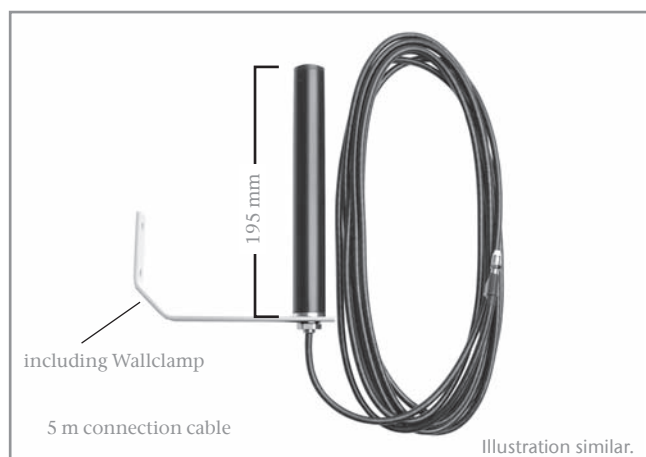

Stationary quadband antenna for wall mounting (in- and outside)

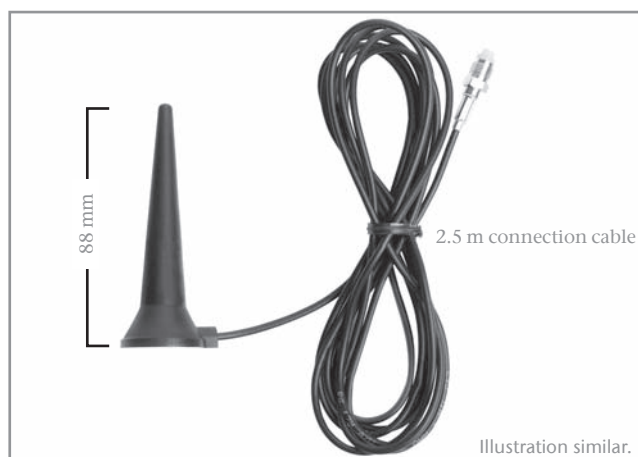

Magnetic base quadband antenna (inside)

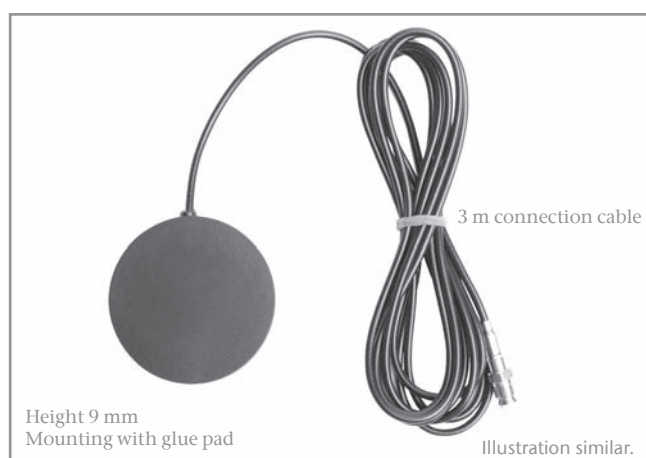

Self-adhesive triband antenna for wall- or glass mounting (inside)



Portable quadband antenna for mobile use (inside)

To ensure the function of the GSM radio system in a – in most cases special – industrial environment, it is important to select a Systeme Helmholtz GSM antenna an advance for the greatest possible reliability.

Despite careful planning, the quality and speed of transmission always also depend on the level of development of and load on the GSM network.

To increase the flexibility still further, corresponding GSM extensions of various lengths are available as accessories for the antennas offered.

Stationary quadband antenna

The stationary quadband antenna is a non-directional station antenna with a gain of up to 2 dBi. It is protected in a robust and weatherproof GFK conduit, is supplied with a wall mount, and is therefore especially suitable for mounting on vertical surfaces, such as building walls etc. It can be used equally well both outdoors and indoors. Metal surfaces should not be located in proximity to the emitting antenna. The 5 m long connecting cable is permanently connected to the antenna.

Ordering Data	Order No.
Stationary quadband antenna	700-751-ANT11
Magnetic base quadband antenna	700-751-ANT12
Self-adhesive triband antenna	700-751-ANT13
Portable quadband antenna	700-751-ANT14
GSM antenna extension cable, 5 m	700-751-ANTK01
GSM antenna extension cable, 10 m	700-751-ANTK02
GSM antenna extension cable, 15 m	700-751-ANTK03
GSM antenna extension cable, 20 m	700-751-ANTK04

Magnetic base quadband antenna

The quadband magnetically adhering antenna supports all relevant GSM radio frequencies. It adheres reliably to all magnetic surfaces because of its strong permanent magnet. Due to its compact dimensions, this omnidirectional antenna is ideal for mounting on the top or side of a cabinet. The 2.5 m long connecting cable provides a sufficient radius of action for this and is permanently connected to the antenna.

Self-adhesive triband antenna

Patch antenna with a flat, robust design for indoor use. It is fixed by means of an adhesive pad on preferably horizontal surfaces. It functions independently of external grounding surfaces and can be mounted on nearly any material. The 3 m long connecting cable is permanently attached and can exit in the horizontal or vertical direction.

Portable quadband antenna

Small quadband omnidirectional antenna for direction connection to the GSM modem. For this type of antenna, a minimum clearance of 60 cm from other antennas and standing metal parts must be ensured on all sides in the application.

The antennas can be used in conjunction with the following products:

REX 300, SSW7-TS PRO, SSW7-TS with modem and TS 300 in the GSM variant in each case.

Note

All antennas are UMTS/HSDPA-compatible.

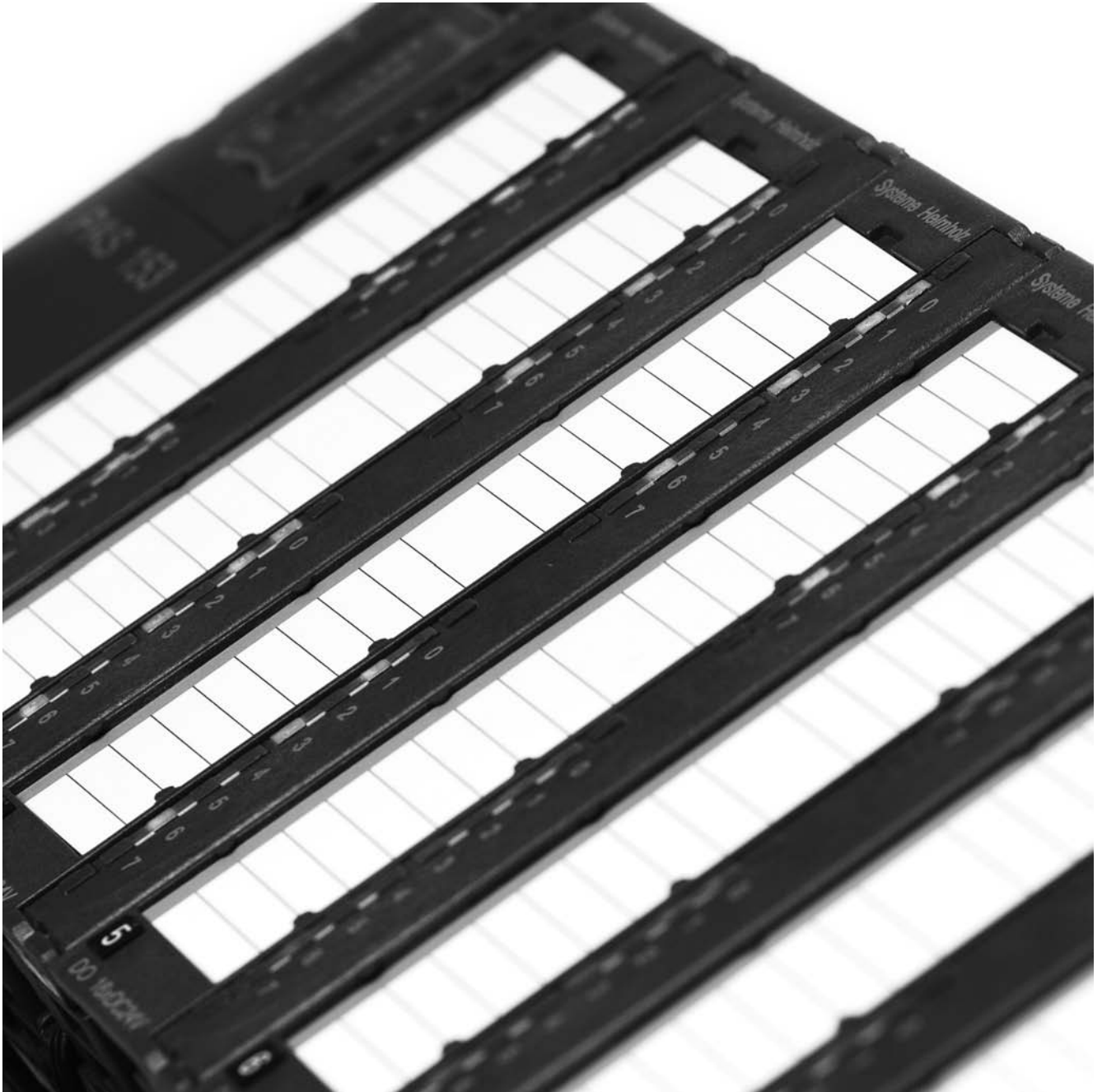

Components for S7

Micro Memory Cards
Memory Cards
Digital Modules
Analog Modules
Front Connectors

Micro Memory Cards

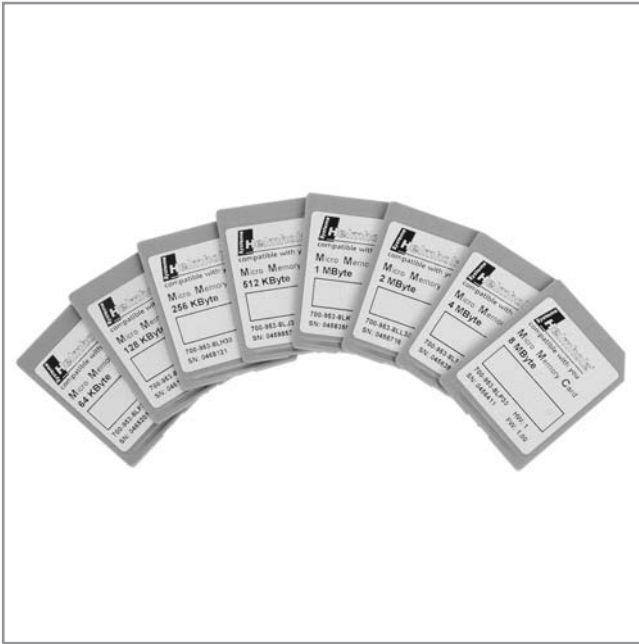

Micro Memory Cards



The Micro Memory Cards from the Systeme Helmholtz GmbH are suitable for use in S7 controllers.

Our product program includes the whole range of the most commonly required modules plus the special variants 256 kB and 1 MB.

The Micro Memory Cards are available with the following memory capacities: 64 kB, 128 kB, 256 kB, 512 kB, 1 MB, 2 MB, 4 MB, 8 MB.

We are able to offer you a very advantageous price-performance ratio due to our modern production methods.

Ordering Data	Order No.
Micro Memory Cards	
64 kByte	700-953-8LF30
128 kByte	700-953-8LG30
256 kByte	700-953-8LH30
512 kByte	700-953-8LJ30
1 MByte	700-953-8LK30
2 MByte	700-953-8LL30
4 MByte	700-953-8LM30
8 MByte	700-953-8LP30

Technical Data	
Micro Memory Cards	
Memory capacity	64 kByte 128 kByte 256 kByte 512 kByte 1 MByte 2 MByte 4 MByte 8 MByte
Applications	CPU 312C CPU 313C CPU 314C CPU 312 ... 317, new type IM 151, IM 153, IM 154 CPU C7



Memory Card, long type



Memory Cards from the Systeme Helmholtz GmbH are designed for use in CPU modules CPU 412 to CPU 417. We have been able to achieve top quality standards and a very advantageous price-performance ratio with the use of modern manufacturing methods. Our product program covers the range of the most common submodules.

Ordering Data	Order No.
Flash EPROM Cards, long	
64 kByte	700-952-0KF00
256 kByte	700-952-0KH00
1 MByte	700-952-1KK00
2 MByte	700-952-1KL00
4 MByte	700-952-1KM00
8 MByte	700-952-1KP00
16 MByte	700-952-1KS00
RAM Cards, long	
64 kByte	700-952-0AF00
256 kByte	700-952-1AH00
1 MByte	700-952-1AK00
2 MByte	700-952-1AL00
4 MByte	700-952-1AM00
8 MByte	700-952-1AP00

Technical Data	
Flash EPROM Cards, long Memory capacity	64 kByte, 256 kByte, 1 MByte, 2 MByte, 4 MByte, 8 MByte, 16 MByte
Applications	CPU 412 to 417
RAM Cards, long Memory capacity	64 kByte, 256 kByte, 1 MByte, 2 MByte, 4 MByte, 8 MByte
Applications	CPU 412 to 417

DEA 300, Digital Input Modules



Digital input modules with 16 and 32 inputs

Accessory-Note

The Systeme Helmholtz GmbH supplies front connectors and cable sets (see page 89-91).



Open type Programmable Controllers, for use in Hazardous Locations, Class I, Div. 2 Groups A, B, C, D T4 including Class I Zone 2 IIC.

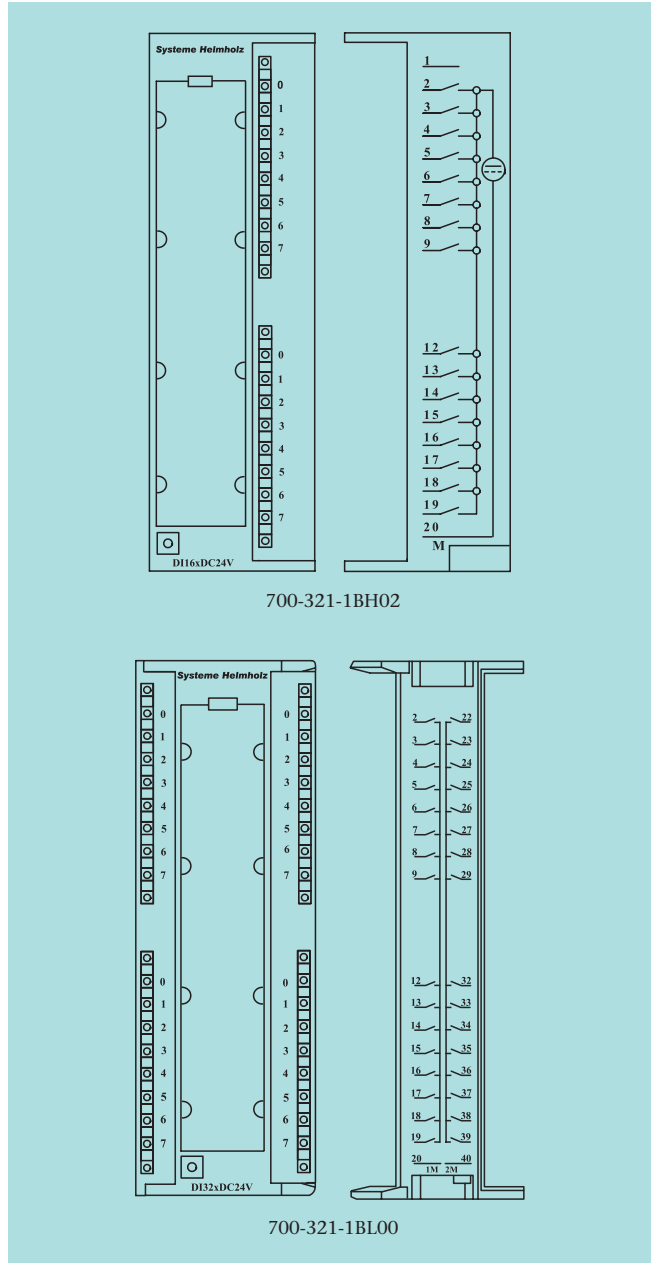

Ordering Data	Order No.
DEA 300	
16 inputs (DC 24 V)	700-321-1BH02
32 inputs (DC 24 V)	700-321-1BL00
Manual DEA 300, German/English	900-321-1DE11

Technical Data		
	700-321-1BH02	700-321-1BL00
Number of inputs	16	32
Isolation (from backplane bus) In groups of	Yes (optocoupler) 16	Yes (optocoupler) 16
Input voltage • nom. value • for "0" signal • for "1" signal	DC 24 V -3 ... +5 V +13 ... +30 V	DC 24 V -3 ... +5 V +13 ... +30 V
Input current • for "1" signal	typ. 7 mA	7 mA
Delay time	typ. 1.2 ... 4.8 ms	1.2 ... 4.8 ms
Connection of 2-wire initiator Perm. quiescent current for "0" signal	Yes max. 1.5 mA	Yes 1.5 mA
Cable length • unshielded • shielded	max. 600 m max. 1000 m	600 m 1000 m
Current consumption • internal (backplane bus) • external (from +24 V)	typ. 20 mA max. 140 mA	30 mA 290 mA
Power loss (rated operation)	typ. 3.5 W	6.8 W
Front connector	20-way	40-way
Ambient temperature Transport and storage temperature	0 °C ... 60 °C -25 °C ... 75 °C	0 °C ... 60 °C -25 °C ... 75 °C

DEA 300, Digital Input Module, m-reading



DEA 300, m-reading

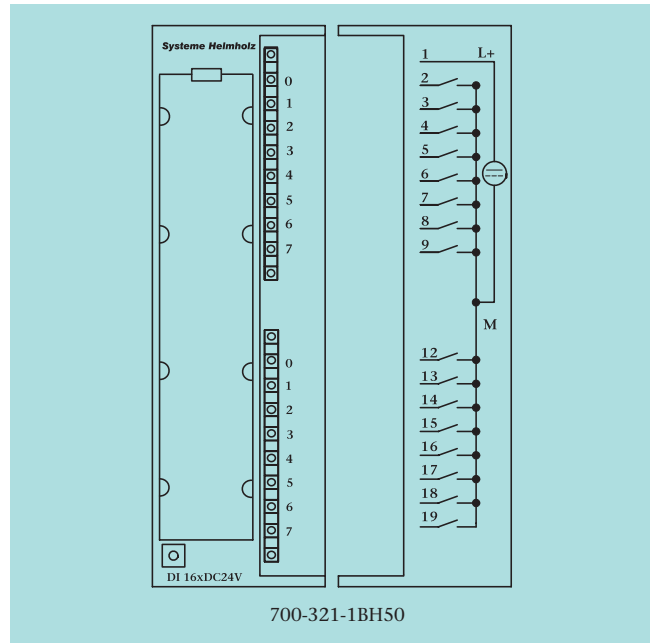

700-321-1BH50

Accessory-Note

The Systeme Helmholtz GmbH supplies front connectors and cable sets (see page 89-91).

Ordering Data	Order No.
DEA 300 16 inputs, m-reading	700-321-1BH50
Manual DEA 300, German/English	900-321-1DE11

Technical Data	
Number of inputs	16
Isolation against backplane bus In groups of	Yes (optocoupler) 16
Input voltage, reference potential is L+ <ul style="list-style-type: none"> • nom. value • for Signal "0" • for Signal "1" 	DC 24 V +30 ... -5 V -13 ... -30 V
Input current <ul style="list-style-type: none"> • for Signal "1" 	7 mA
Delay time	1.2 ... 4.8 ms
Cable length <ul style="list-style-type: none"> • unshielded • shielded 	600 m 1000 m
Current consumption <ul style="list-style-type: none"> • internal (backplane bus) 	10 mA
Power loss (nominal operation)	3.5 W
Front connector	20-way
Ambient temperature Transport and storage temperature	0 °C ... 60 °C -25 °C ... 75 °C



Digital output modules with 16 and 32 outputs

Accessory-Note

The Systeme Helmholz GmbH supplies front connectors and cable sets (see page 89-91).



Open type Programmable Controllers, for use in Hazardous Locations, Class I, Div. 2 Groups A, B, C, D T4 including Class I Zone 2 IIC.

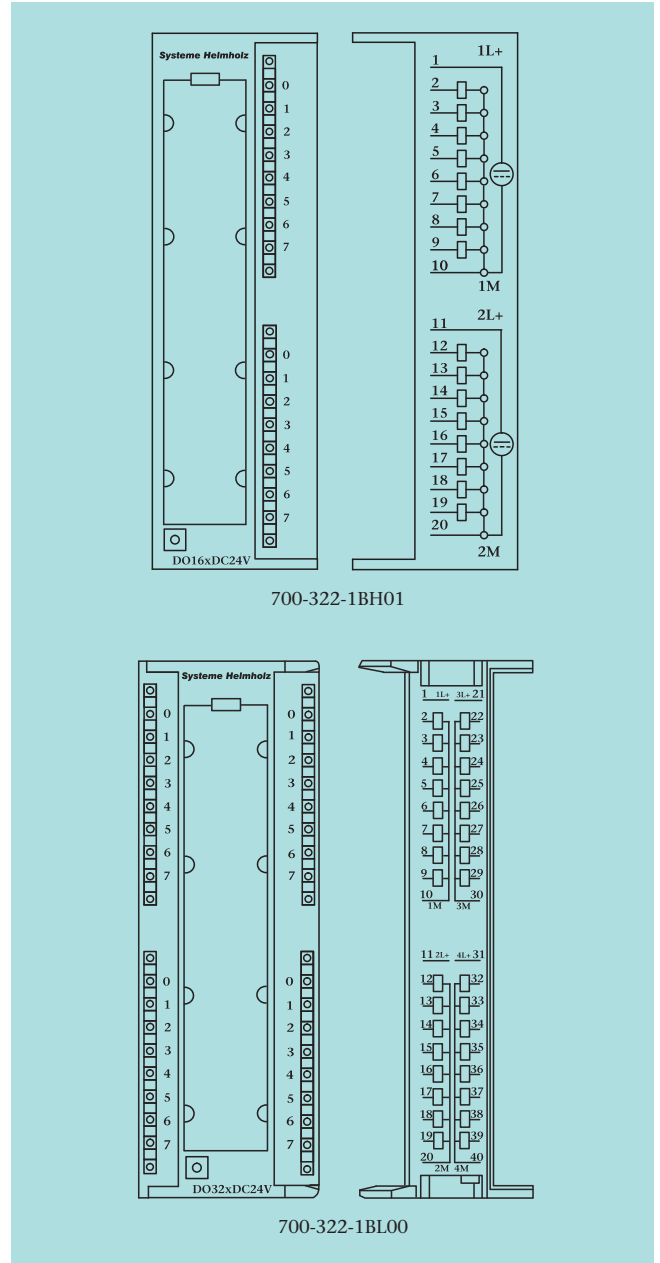

700-322-1BH01

700-322-1BL00

Ordering Data	Order No.
DEA 300	
16 outputs (DC 24 V; 0,5 A)	700-322-1BH01
32 outputs (DC 24 V; 0,5 A)	700-322-1BL00
Manual DEA 300, German/English	900-321-1DE11

Technical Data		
	700-322-1BH01	700-322-1BL00
Number of outputs	16	32
Isolation against backplane bus In groups of	Yes (optocoupler) 8	Yes (optocoupler) 8
Supply voltage V_p, V_s • nom. value • ripple V_{pp} • permissible range (with ripple) • value at $t < 10$ ms	max. DC 24 V 3.6 V 20 ... 30 V max. 50 V	DC 24 V 3.6 V 20 ... 30 V 50 V
Output current • nom. value	0.5 A	0.5 A
Short-circuit protection	Electrical	Electrical
Voltage induced on circuit interruption limited to	-48 V	-48 V
Cable length • unshielded • shielded	max. 600 m max. 1000 m	600 m 1000 m
Current consumption • internal (backplane bus) • ext. w/o load (from +24 V)	max. 100 mA typ. 120 mA	125 mA 200 mA
Power loss (nominal operation)	typ. 5 W	6.8 W
Front connector	20-way	40-way
Ambient temperature Transport and storage temperature	0 °C ... 60 °C -25 °C ... 75 °C	0 °C ... 60 °C -25 °C ... 75 °C



Digital input/output modules

Accessory-Note

The Systeme Helmholtz GmbH supplies front connectors and cable sets (see page 89-91).



Open type Programmable Controllers, for use in Hazardous Locations, Class I, Div. 2 Groups A, B, C, D T4 including Class I Zone 2 IIC.

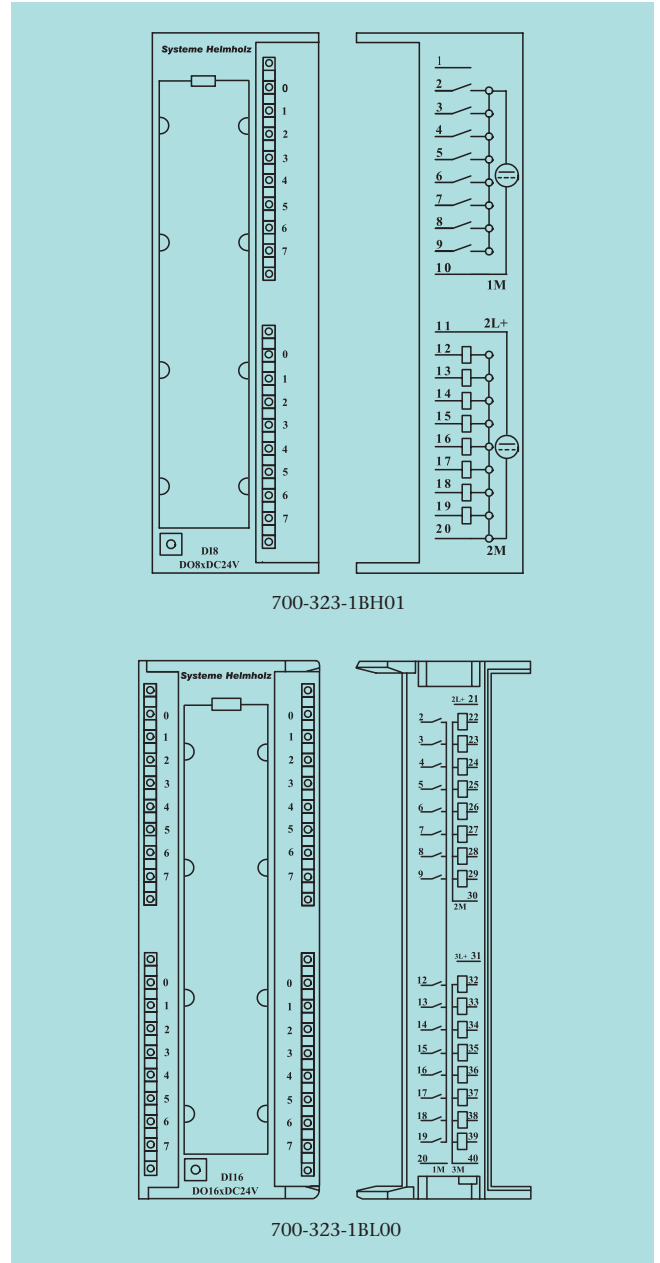

Ordering Data	Order No.
DEA 300	
8 inputs (DC 24 V)/ 8 outputs (DC 24 V; 0,5 A)	700-323-1BH01
16 inputs (DC 24 V)/ 16 outputs (DC 24 V; 0,5 A)	700-323-1BL00
Manual DEA 300, German/English	900-321-1DE11

Technical Data		
	700-323-1BH01	700-323-1BL00
Number of inputs	8	16
Isolation (from backplane bus) In groups of	Yes (optocoupler) 8	Yes (optocoupler) 16
Input voltage • nom. value • for Signal "0" • for Signal "1"	DC 24 V -3 ... +5 V +13 ... +30 V	DC 24 V -3 ... +5 V +13 ... +30 V
Input current • for "1" signal	typ. 7 mA	7 mA
Delay time	typ. 1.2 ... 4.8 ms	1.2 ... 4.8 ms
Connection of 2-wire initiator Perm. quiescent current for "0" signal	Yes max. 1.5 mA	Yes 1.5 mA
Cable length • unshielded • shielded	max. 600 m max. 1000 m	600 m 1000 m
Number of outputs	8	16
Isolation (from backplane bus) in groups of	Yes (optocoupler) 8	Yes (optocoupler) 8
Output current • nom. value	0.5 A	0.5 A
Short-circuit protection	Electronic	Electronic
Voltage induced on circuit interruption limited to	- 48 V	- 48 V
Cable length • unshielded • shielded	max. 600 m max. 1000 m	600 m 1000 m
Supply voltage V_p, V_s • nom. value • ripple V_{pp} • permissible range (with ripple) • value at $t < 10$ ms	max. DC 24 V 3.6 V 20 ... 30 V max. 50 V	DC 24 V 3.6 V 20 ... 30 V 50 V
Current consumption • internal (backplane bus) • external (without load, from +24 V)	max. 55 mA typ. 60 mA	90 mA 120 mA
Power loss (nominal operation)	typ. 3.5 W	6.8 W
Front connector	20-way	40-way
Ambient temperature Transport and storage temperature	0 °C ... 60 °C -25 °C ... 75 °C	0 °C ... 60 °C -25 °C ... 75 °C



Digital output module; 8 outputs, 2 amps

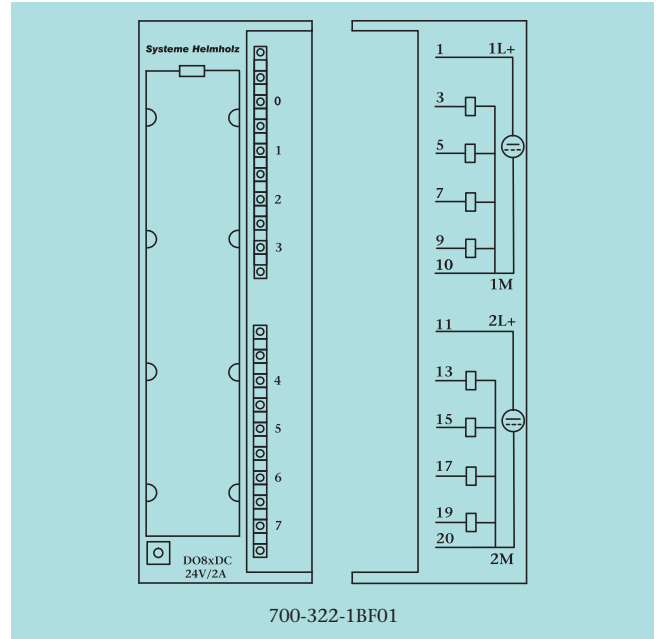

Accessory-Note
 The Systeme Helmholtz GmbH supplies front connectors and cable sets (see page 89-91).



Technical Data	
Number of outputs	8
Isolation (from backplane bus) In groups of	Yes (optocoupler) 4
Supply voltage V_p, V_s	
• nom. value	DC 24 V
• ripple V_{pp} max.	3.6 V
• permissible range (with ripple)	20 ... 30 V
• value at $t < 10$ ms max.	40 V
Output current	
• nom. value	2 A
Aggregate current of the outputs (per group, horizontal mounting)	
• to 40 °C	8 A
• to 55 °C	6 A
Short-circuit protection	Electronic
Short-circuit current typ.	12 A clocked
Voltage induced on circuit interruption limited to	- 23 V
Cable length	
• unshielded max.	600 m
• shielded max.	1000 m
Current consumption	
• internal (backplane bus) max.	40 mA
• ext.(without load, from +24 V) typ.	60 mA
Power loss (nominal operation) typ.	6.8 W
Front connector	20-way
Ambient temperature	0 °C ... 60 °C
Transport and storage temperature	-25 °C ... 75 °C

Ordering Data	Order No.
DEA 300 8 outputs (DC 24 V; 2 A)	700-322-1BF01
Manual DEA 300, German/English	900-321-1DE11

DEA 300, Digital Output; Relays



Digital output convert; 8 relays

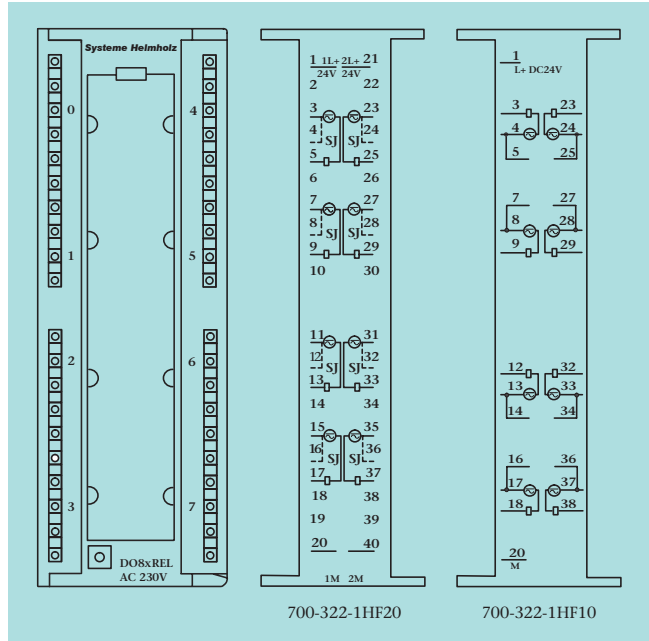

Accessory-Note

The Systeme Helmholtz GmbH supplies front connectors and cable sets (see page 89-91).



Technical Data	
Number of outputs	8
Nom. load voltage L+/L-	DC 24 V
Switching voltage	AC to 230 V DC to 120 V
Output current Aggregate current of the output (per group)	max. 5 A
Isolation to • backplane bus • in groups	Optocoupler 1
Switching frequency • resistive load • inductive load • lamp load • mechanical	max. 2 Hz max. 0.5 Hz max. 2 Hz max. 10 Hz
Rated load • resistive load • inductive load	max. 8 A (AC 230 V) 8 A (DC 24 V) max. 3 A (AC 230 V) 2 A (DC 24 V)
Expected life • mechanical • resistive load	10 Mio. 5 A, 0.2 Mio.
Ambient temperature Transport and storage temperature	0 °C ... 60 °C -25 °C ... 75 °C

Ordering Data	Order No.
DEA 300	
8 outputs, relays, 5 A	700-322-1HF10
8 outputs, relays, 5 A, snubber	700-322-1HF20
Manual DEA 300, German/English	900-321-1DE11



Digital output convert, 16 relays

Accessory-Note

The Systeme Helmholz GmbH supplies front connectors and cable sets (see page 89-91).



Order No. 700-322-1HH01:

Open type Programmable Controllers, for use in Hazardous Locations, Class I, Div. 2 Groups A, B, C, D T6 including Class I Zone 2, IIC.

Technical Data		
	700-322-1HH01	700-322-1HF01
Number of outputs	16	8
Nom. load voltage L+/L-	DC 24 V	DC 24 V
Switching voltage	AC to 230 V DC to 120 V	AC to 230 V DC to 120 V
Output current Aggregate current of the output (per group) max.	8 A	4 A
Isolation to backplane bus • in groups	Optocoupler 8	Optocoupler 2
Continuos thermal current	2 A	3 A
Switching frequency • resistive load max. • inductive load max. • lamp load max. • mechanical max.	1 Hz 0,5 Hz 1 Hz 10 Hz	2 Hz 0,5 Hz 2 Hz 10 Hz
Rated load • resistive load max. • inductive load max.	2 A (AC 230 V) 2 A (DC 24 V) 2 A (AC 120 V) 2 A (DC 24 V)	2 A (AC 230 V) 2 A (DC 24 V) 2 A (AC 120 V) 2 A (DC 24 V)
Expected life • mechanical • resistive load	10 Mio. 2 A, 1 Mio.	10 Mio. 2 A, 0.7 Mio.
Ambient temperature Transport and storage temperature	0 °C ... 60 °C -25 °C ... 75 °C	0 °C ... 60 °C -25 °C ... 75 °C

Ordering Data	Order No.
DEA 300 16 outputs, relays, 2 A 8 outputs, relays, 2 A	700-322-1HH01 700-322-1HF01
Manual DEA 300 , German/English	900-321-1DE11

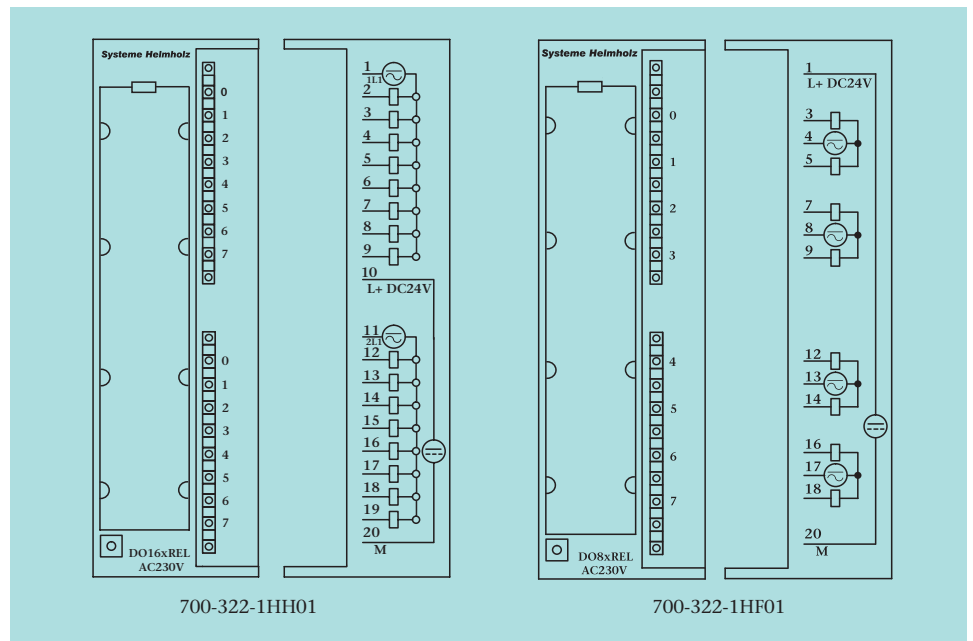

DEA 300, Digital Output; Relays Bistable



DEA 300, Digital Output; Relays Bistable

Our DEA 300 bistable module holds its' outputs state even when supply current is switched of or suffers breakdown.

Accessory-Note

The Systeme Helmholz GmbH supplies front connectors and cable sets (see page 89-91).

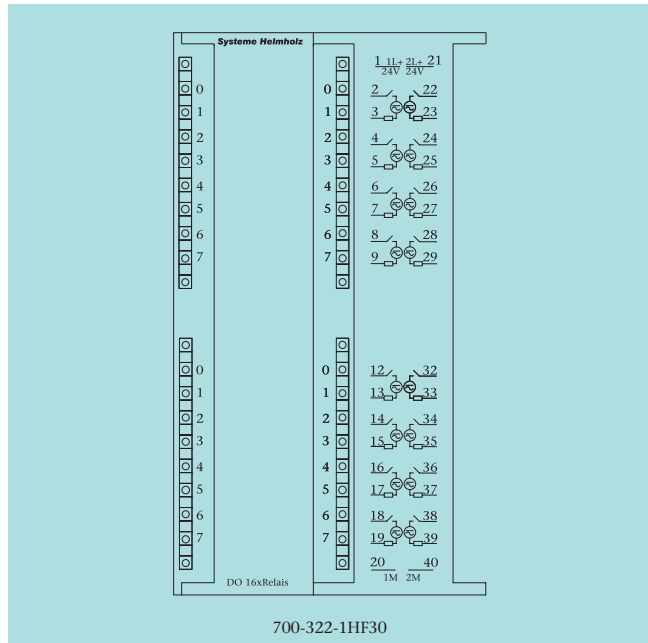

Ordering Data	Order No.
DEA 300 16 outputs, relays, bistable	700-322-1HF30
Manual DEA 300 , German/English	900-321-1DE11

Technical Data	
Number of outputs	16
Nom. load voltage L+/L-	DC 24 V
Switching voltage	max. AC to 50 V max. DC to 60 V
Isolation (from backplane bus)	Optocoupler
Continuos thermal current	0.5 A
Switching frequency	
• resistive load	max. 20 Hz
• mechanical	max. 180 Hz
Energisation of the solenoid to ensure relay switching	min 10 ms
Switching capacity and lifetime of contacts	
• resistive load	0.5 A; 0.7 Mio.
Front connector	40-way
Ambient temperature	0 °C ... 60 °C
Transport and storage temperature	-25 °C ... 75 °C



Digital input convert, 120/230 V

Accessory-Note

The Systeme Helmholz GmbH supplies front connectors and cable sets (see page 89-91).



Open type Programmable Controllers, for use in Hazardous Locations, Class I, Div. 2 Groups A, B, C, D T4 including Class I Zone 2 IIC.

Technical Data		700-321-1FH00	700-321-1EL00
Number of inputs		16	32
Isolation to backplane bus		Yes (optocoupler)	Yes (optocoupler)
• in groups		4	8
Input voltage		120/230 V AC	120 V AC
• nom. value (input voltage must be equal on all phases)			
• for Signal "0"		0 ... 40 V	0 ... 20 V
• for Signal "1"		79 ... 264 V	74 ... 132 V
• frequency range		47 ... 63 Hz	47 ... 63 Hz
Input current for signal "1"			
• 120 V, 60 Hz	typ.	8 mA	22 mA
• 230 V, 50 Hz	typ.	13 mA	-
Delay time			
• from "0" to "1"	typ.	25 ms	15 ms
• from "1" to "0"	typ.	25 ms	25 ms
Cable length			
• unshielded	max.	600 m	600 m
• shielded	max.	1000 m	1000 m
Current consumption			
• internal	max	30 mA	16 mA
Power loss	typ.	4.5 W	5.8 W
Ambient temperature		0 °C ... +60 °C	0 °C ... +60 °C
Transport and storage temperature		-25 °C ... +75 °C	-25 °C ... +75 °C

Ordering Data	Order No.
DEA 300 16 inputs, AC 120 V/230 V 32 inputs, AC 120 V	700-321-1FH00 700-321-1EL00
Manual DEA 300, German/English	900-321-1DE11

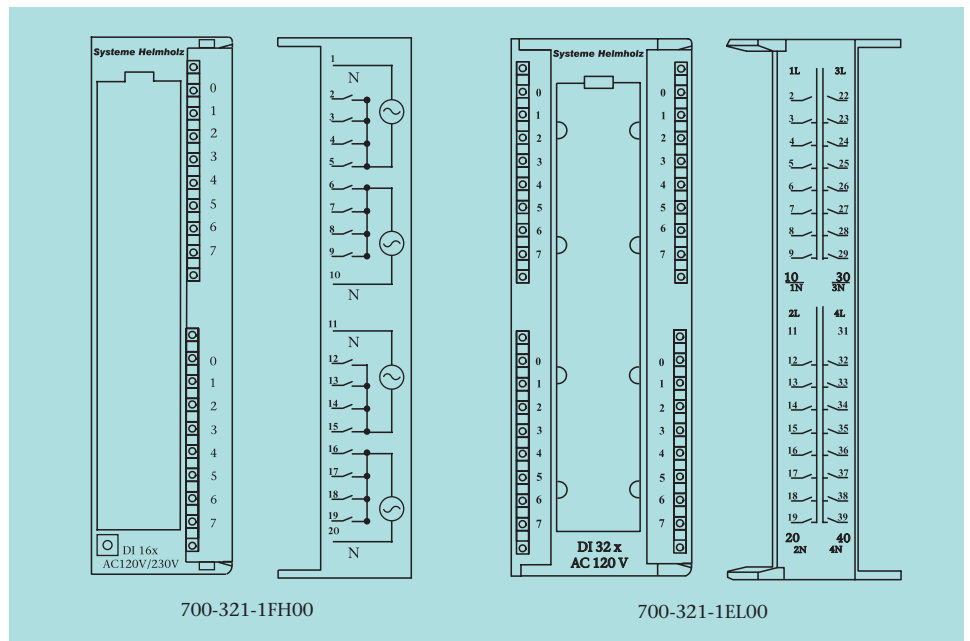

AEA 300, Analog Input Module for Connecting Sensors with Current Signals



Analog input module

The analog input modules from the Systeme Helmholz GmbH are suitable for connection of sensors with current signals in the range up to ± 20 mA. The signal lines are connected to the corresponding front connectors. You can identify them on the labeling strip. The modules can be fully parameterized with the hardware configurator of the programming software. Hardware configuration is not necessary (no range card).

Accessory-Note

The Systeme Helmholz GmbH supplies front connectors and cable sets (see page 89-91).



Open type Programmable Controllers, for use in Hazardous Locations, Class I, Div. 2 Groups A, B, C, D T6 including Class I Zone 2, IIC.

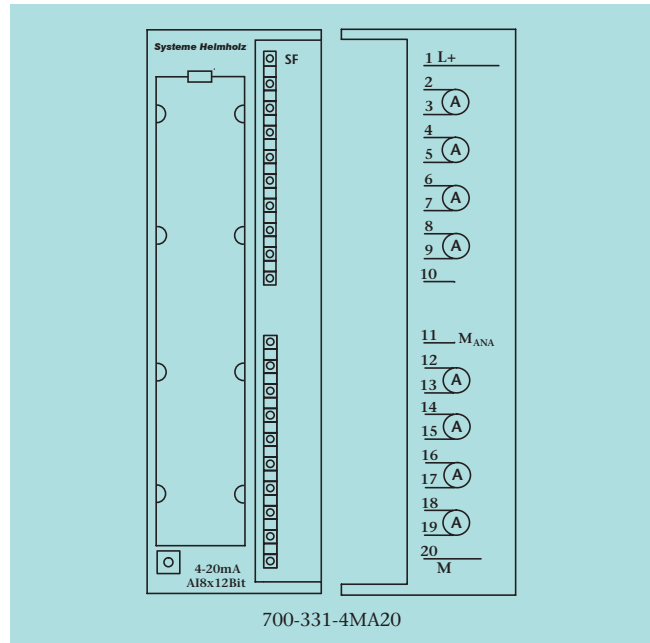

Technical Data	
Number of inputs	8
Alarms	Parameterizable Parameterizable for channels 0 and 2
<ul style="list-style-type: none"> limit value alarm diagnostic alarm 	
Diagnostics	Red LED for group error display
Nom. load voltage L+/L-	DC 24 V
Polarity reversal protection	Yes
Input ranges	
<ul style="list-style-type: none"> current, 4 DMU 	± 3.2 mA/25 Ω ± 10 mA/25 Ω 0 ... 20 mA/25 Ω 4 ... 20 mA/25 Ω ± 20 mA/25 Ω 4 ... 20 mA/25 Ω
<ul style="list-style-type: none"> current, 2 DMU 	± 20 mA/25 Ω 4 ... 20 mA/25 Ω
Permissible input current for current input	max. 40 mA
Isolation against backplane bus	Yes
Conversion time/resolution (per chann.)	
<ul style="list-style-type: none"> integration time noise suppression for interference frequency resolution (SG = sign) (depends on integration time) 	2.5/16.6/20/100 ms 400/60/50/10 Hz 9 + VZ / 12 + VZ / 12 + VZ / 14 + VZ Bit
Operational limit	max. $\pm 0.6\%$
Basic error limit at 25 °C	max. $\pm 0.5\%$
Cable length (shielded)	200 m
Current consumption	
<ul style="list-style-type: none"> internal (backplane bus) external (L+) 	typ. 120 mA max. 200 mA
Power loss	typ. 1.8 W
Front connector	20-way
Ambient temperature	0 °C ... +60 °C
Transport and storage temperature	-25 °C ... +75 °C

Ordering Data	Order No.
AEA 300 8 current inputs for connecting current sensors	700-331-4MA20
Manual AEA 300, German/English	900-331-0AA01



Analog input module

The analog input modules from the Systeme Helmholz GmbH are suitable for connection of sensors with voltage signals in the range up to ± 10 V. The signal lines are connected to the corresponding front connectors. You can identify them on the labeling strip. The modules can be fully parameterized with the hardware configurator of the programming software. Hardware configuration is not necessary (no range card).

Accessory-Note

The Systeme Helmholz GmbH supplies front connectors and cable sets (see page 89-91).



Open type Programmable Controllers, for use in Hazardous Locations, Class I, Div. 2 Groups A, B, C, D T6 including Class I Zone 2, IIC.

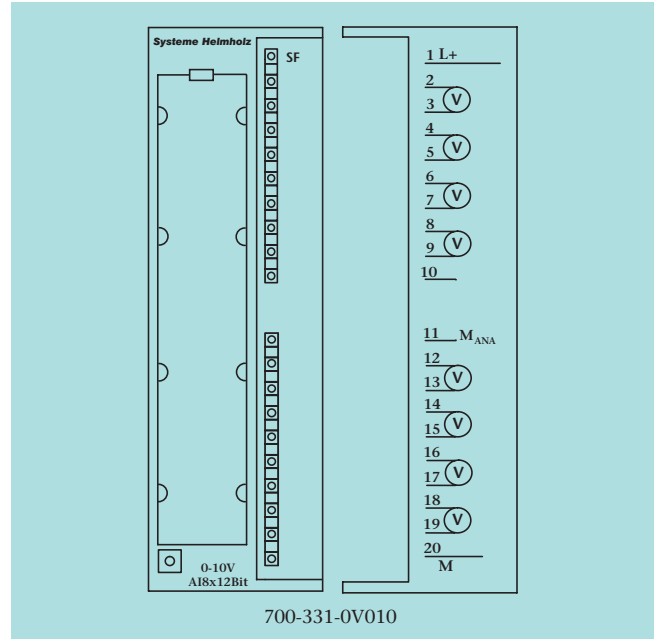

Technical Data

Number of inputs	8
Alarms	Parameterizable Parameterizable for channels 0 and 2
<ul style="list-style-type: none"> diagnostic alarm limit value alarm 	
Diagnostics	Red LED for group error display
Nom. load voltage L+/L-	DC 24 V
Polarity reversal protection	Yes
Input ranges	<ul style="list-style-type: none"> ± 80 mV/10 M Ω ± 250 mV/10 M Ω ± 500 mV/10 M Ω ± 1 V/10 M Ω ± 2.5 V/100 k Ω ± 5 V/100 k Ω 1 ... 5 V/100 k Ω ± 10 V/100 k Ω
Permiss. input voltage for voltage input	max. 20 V
Isolation against backplane bus	Yes
Conversion time/resolution (per channel)	<ul style="list-style-type: none"> integration time: 2.5/16.6/20/100 ms noise suppression for interference frequency: 400/60/50/10 Hz resolution (SG = sign) (depends on integration time): 9 + VZ / 12 + VZ / 12 + VZ / 14 + VZ Bit
Operational limit	max. $\pm 0.6\%$
Basic error limit at 25 °C	max. $\pm 0.5\%$
Cable length (shielded)	max. 200 m (50 m at ± 80 mV)
Current consumption	<ul style="list-style-type: none"> internal (backplane bus) typ. 120 mA external (L+) max. 200 mA
Power loss	typ. 1.8 W
Front connector	20-way
Ambient temperature	0 °C ... +60 °C
Transport and storage temperature	-25 °C ... +75 °C

Ordering Data	Order No.
AEA 300 8 voltage inputs, for connection of voltage sensors	700-331-0V010
Manual AEA 300, German/English	900-331-0AA01

AEA 300, Analog Input Module for Connecting Resistance Thermometers



Analog input module

The analog input modules from the Systeme Helmholtz GmbH are suitable for connection of Pt100/Ni100 sensors and resistors. The signal lines are connected to the corresponding front connectors. You can identify them on the labeling strip. The modules can be fully parameterized with the hardware configurator of the programming software. Hardware configuration is not necessary (no range card).

Accessory-Note

The Systeme Helmholtz GmbH supplies front connectors and cable sets (see page 89-91).



Open type Programmable Controllers, for use in Hazardous Locations, Class I, Div. 2 Groups A, B, C, D T6 including Class I Zone 2, IIC.

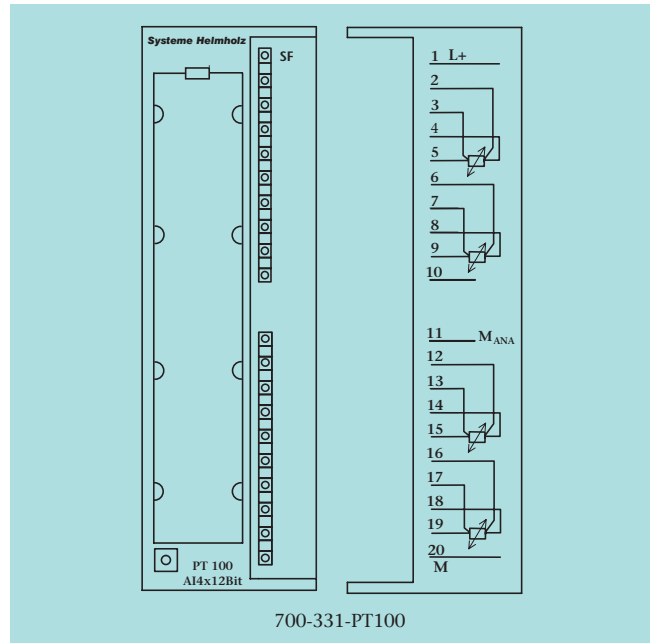

700-331-PT100

Technical Data

Number of inputs	4
Alarms	Parameterizable Parameterizable for channels 0 and 2
<ul style="list-style-type: none"> limit value alarm diagnostic alarm 	
Diagnostics	Red LED for group error display
Nom. load voltage L+/L-	DC 24 V
Polarity reversal protection	Yes
Input resistance	10 M Ω
Resistance thermometer	Pt100, Ni100 (standard and climatic range)
Resistance range	150, 300, 600 Ω
Sensor connection	2-, 3- or 4-wire connection
Isolation against backplane bus	Yes
Conversion time/resolution (per channel)	
<ul style="list-style-type: none"> integration time noise suppression for interference frequency resolution (SG = sign) (depends on integration time) 	2,5/16,6/20/100 ms 400/60/50/10 Hz 9 + VZ/12 + VZ/ 12 + VZ/14 + VZ Bit
Operational limit	max. $\pm 0.6\%$
Basic error limit at 25 °C	max. $\pm 0.5\%$
Cable length (shielded)	max. 200 m
Current consumption	
<ul style="list-style-type: none"> internal (backplane bus) external (L+) 	typ. 120 mA max. 200 mA
Power loss	typ. 1,8 W
Front connector	20-way
Ambient temperature	0 °C ... +60 °C
Transport and storage temperature	-25 °C ... +75 °C

Ordering Data	Order No.
AEA 300 4 inputs, Pt100/Ni100 resistance thermometers	700-331-PT100
Manual AEA 300, German/English	900-331-0AA01



Analog input module, 8 channel, current signals, voltage signals, resistance, resistance thermometer

The analog input modules from the Systeme Helmholtz GmbH are suitable for connection of sensors with current signals in the range up to ± 20 mA, of sensors with voltage signals in the range up to ± 10 V, of Pt100/Ni100 sensors and resistors. All inputs are freely configurable as voltage or current input, resistance or resistance thermometer Pt100/Ni100, in any desired combination. The signal lines are connected to the corresponding front connectors. You can identify them on the labeling strip. The modules can be fully parameterized with the hardware configurator of the programming software. Hardware configuration is not necessary (no range card).

Accessory-Note

The Systeme Helmholtz GmbH supplies front connectors and cable sets (see page 89-91).

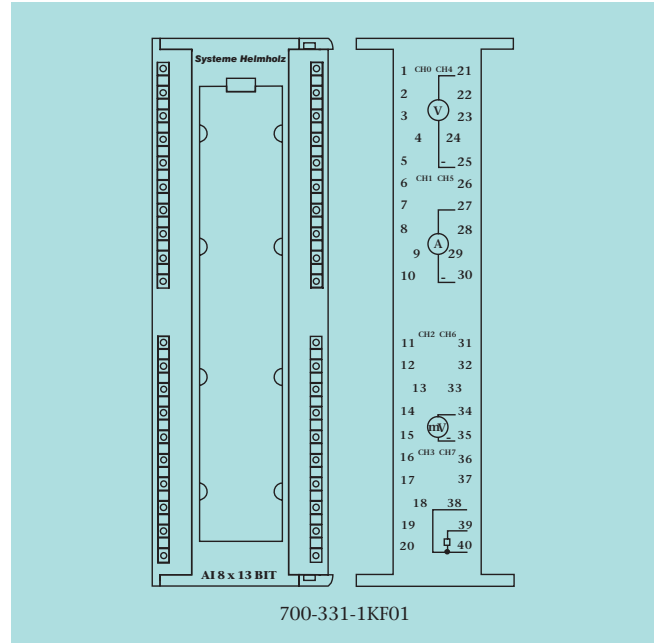

Example configuration

Technical Data	
Number of inputs	8
Measurement	
• voltage	± 50 mV, ± 500 mV, ± 1 V, ± 5 V, ± 10 V, 1 ... 5V, 0 ... 10 V
• current	± 20 mA, 0 ... 20 mA, 4 ... 20 mA
• resistance	0 ... 6 k Ω , 0 ... 600 Ω
• resistance thermometer (standard and climate)	Pt100, Ni100, Ni1000, LG-Ni1000
Resolution incl. overrange	13 Bit
Error limit	
Basic error limit	at 25 °C
• voltage input	$\pm 0.4\%$
• current input	$\pm 0.4\%$
• resistance	$\pm 0.4\%$
• resistance thermometer	± 0.8 K Pt100 standard, $\pm K$
Operator limit	
• current input	In the whole temperature range $\pm 0.6\%$
• resistance	$\pm 0.6\%$
• resistance thermometer	± 1 K; Pt100, Ni100 standard ± 1.2 K
• voltage input	$\pm 0.6\%$
Supply voltage	
Nominal voltage	DC 5 V by backplane bus
Current demand	Typ. 160 mA at 5 V (from backplane bus)
Power loss	Approx. 0.8 W
Front connector	32 Bit-DEA300 Front connector (40-way)
Ambient temperature	0 °C ... +60 °C
Transport and storage temperature	-25 °C ... +75 °C

Ordering Data	Order No.
AEA 300 8 inputs, for connection of current signals, voltage signals, resistance thermometer	700-331-1KF01
Manual AEA 300, German/English	900-331-0AA01

AEA 300, Analog Output Module; 4-Channel



4-channel analog output module

The analog output modules from the Systeme Helmholz GmbH are suitable for connection of analog actuators for voltage and current outputs in the range up to ± 10 V or ± 20 mA. The signal lines are connected to the corresponding front connectors. You can identify them on the labeling strip. The modules can be fully configured with the programming software. Hardware switchover is not necessary.

Accessory-Note

The Systeme Helmholz GmbH supplies front connectors and cable sets (see page 89-91).



Open type Programmable Controllers, for use in Hazardous Locations, Class I, Div. 2 Groups A, B, C, D T6 including Class I Zone 2, IIC.

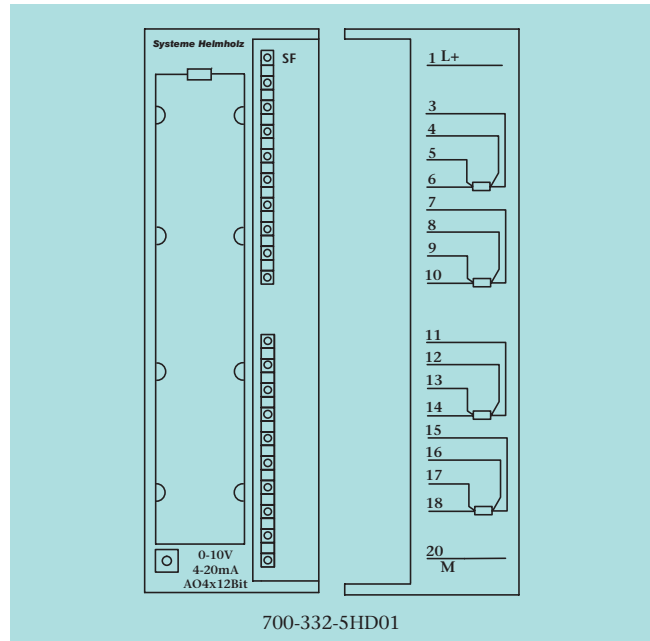

700-332-5HD01

Technical Data

Number of outputs	4
Diagnostics alarm	Yes, parameterizable
Diagnostics	Red LED for group error display
Nom. load voltage	DC 24 V
Output ranges	
• voltage outputs	0 ... 10 V; ± 10 V; 1 ... 5 V
• current outputs	4 ... 20 mA; ± 20 mA; 0 ... 20 mA
Load impedance	
• for voltage outputs	min. 1 k Ω
• for current outputs	max. 500 Ω
• at capacitive load	max. 1 μ F
• at inductive load	max. 10 mH
Voltage output	
• short-circuit protection	Yes
• short-circuit current	max. 25 mA
Current output	
• open-circuit voltage	max. 18 V
Isolation against backplane bus	Yes
Operational limit (0 to 60 °C, with reference to output range)	
• voltage	± 0.5 %
• current	± 0.6 %
Basic error limit (operational limit at 25 °C, with reference to output range)	
• voltage	± 0.4 %
• current	± 0.5 %
Cable length (shielded)	max. 200 m
Current consumption	
• internal (from backplane bus)	typ. 100 mA
• external, without load	max. 240 mA
Power loss	typ. 3 W
Front connector	20-way
Ambient temperature	0 °C ... +60 °C
Transport and storage temperature	-25 °C ... +75 °C

Ordering Data	Order No.
AEA 300, 4-channel 4 outputs for connecting analog actuators	700-332-5HD01
Manual AEA 300, German/English	900-331-0AA01



2-channel analog output module

The analog output modules from the Systeme Helmholz GmbH are suitable for connection of analog actuators for voltage and current outputs in the range up to ± 10 V or ± 20 mA. The signal lines are connected to the corresponding front connectors. You can identify them on the labeling strip. The modules can be fully configured with the programming software. Hardware switchover is not necessary.

Accessory-Note

The Systeme Helmholz GmbH supplies front connectors and cable sets (see page 89-91).



Open type Programmable Controllers, for use in Hazardous Locations, Class I, Div. 2 Groups A, B, C, D T6 including Class I Zone 2, IIC.

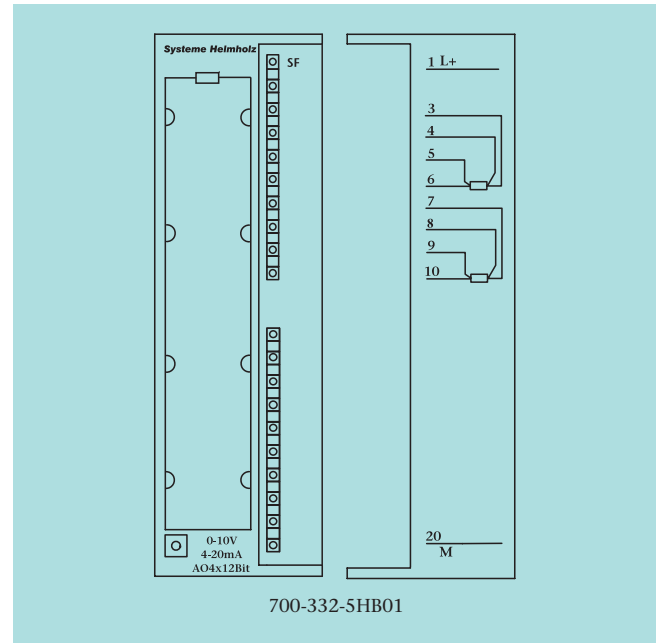

Technical Data

Number of outputs	2
Diagnostics alarm	Yes, parameterizable
Diagnostics	Red LED for group error display
Nom. load voltage	DC 24 V
Output ranges	
• voltage outputs	0 ... 10 V; ± 10 V; 1 ... 5 V
• current outputs	4 ... 20 mA; ± 20 mA; 0 ... 20 mA
Load impedance	
• for voltage outputs	min. 1 k Ω
• for current outputs	max. 500 Ω
• at capacitive load	max. 1 μ F
• at inductive load	max. 10 mH
Voltage output	
• short-circuit protection	Yes
• short-circuit current	max. 25 mA
Current output	
• open-circuit voltage	max. 18 V
Isolation against backplane bus	Yes
Operational limit (0 to 60 °C, with reference to output range)	
• voltage	± 0.5 %
• current	± 0.6 %
Basic error limit (operational limit at 25 °C, with reference to output range)	
• voltage	± 0.4 %
• current	± 0.5 %
Cable length (shielded)	max. 200 m
Current consumption	
• internal (from backplane bus)	typ. 100 mA
• external, without load	max. 240 mA
Power loss	typ. 3 W
Front connector	20-way
Ambient temperature	0 °C ... +60 °C
Transport and storage temperature	-25 °C ... +75 °C

Ordering Data	Order No.
AEA 300, 2-channel 2 outputs for connecting analog actuators	700-332-5HB01
Manual AEA 300, German/English	900-331-0AA01

Dummymodule



Dummymodule

The Dummymodule from the Systeme Helmholz GmbH is for reserving slots for unparameterized signal modules. The structure and address assignment is retained when it is eventually replaced by a signal module. For 20-way or 40-way front connectors.

Meaning of the 8/9-Bit display of the placeholder module

There are two different methods of transmitting data on the backplane bus of the S7-300¹⁾:

- **without parity Bit**
Only the data bytes (8 Bits) are transmitted. This method is obsolete because errors during transmission cannot be detected and the I/Os may be incorrectly switched.
- **with parity Bit**
The new safe method transmits a parity bit in addition to the useful data (9 Bits per byte). That way transmission errors can be detected and incorrect connections avoided.

The CPUs known to us are capable of both transmission methods. Due to reasons of downward compatibility all I/O modules that are capable of the 9-Bit method can also be switched back to the 8-Bit method. This occurs when at least one module is plugged into the system that is only capable of the 8-Bit method. The 8/9-Bit LEDs indicate which method the complete system is using.

If an 8-Bit module is used, all 9-Bit modules on the backplane will only use 8-Bit transmission.

The 9-bit method was introduced shortly after the market launch of the S7-300¹⁾.

However, to ensure downward compatibility, new CPUs are still capable of the 8-Bit method.

Ordering Data	Order No.
Dummymodule, 20-way	700-370-0AA01
Dummymodule, 40-way	700-370-0AL01
Manual DEA 300, German/English	900-321-1DE11

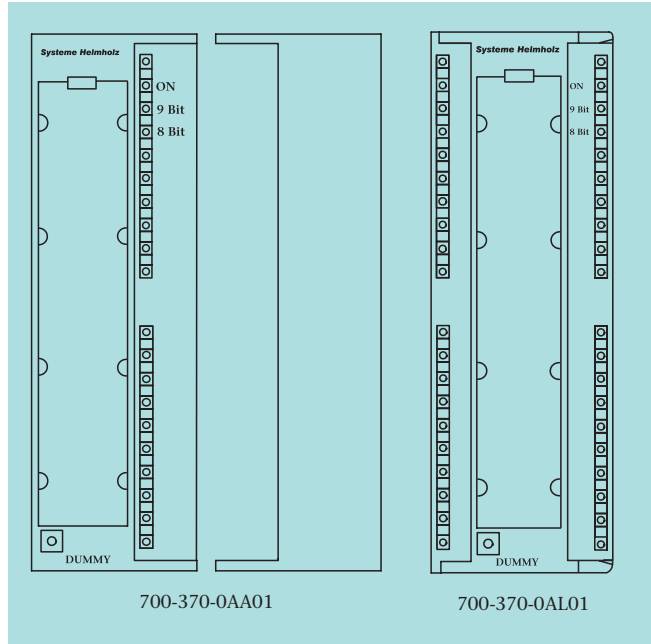

Systeme Helmholz modules all use the reliable 9-Bit method when possible. However, there are older modules possessing just the 8-Bit method on the market. To ensure reliable data transmission on the backplane bus and avoid incorrect switching, we advise against using such modules. The presence of 8-Bit modules can be seen by the shining of the red 8-Bit LED of the placeholder module.

Technical Data	
Current consumption Internal	5 mA
Power loss (nominal operation)	0.03 W
Front connector	-
Ambient temperature	0 °C ... 60 °C
Transport and storage temperature	-25 °C ... 75 °C

1) S7-300 is a registered trademark of Siemens AG



PAS 153, distributed PROFIBUS Interface

Features

- DIP switch for setting the PROFIBUS address
- Up to 16 modules can be plugged in
- Module diagnostics supported
- Can be used on standard sectional rail
- Any combination of modules is possible (analog/digital)
- PROFIBUS-DP up to 12 Mbps
- GSD file is supplied
- Firmware update for expanding functions possible via USB

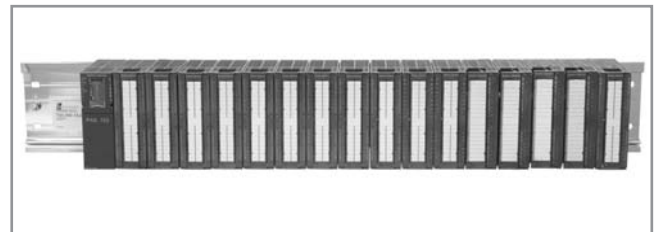

Up to 16 modules can be plugged in

The PAS 153 distributed PROFIBUS Interface from Systeme Helmholz GmbH is for linking digital and analog input and output modules to the PROFIBUS-DP. The module can be mounted on a sectional rail.

Up to 16 modules can be connected to the PAS 153. The PAS 153 is integrated into the hardware configurer of the programming system by a GSD file. The PAS 153 Interface performs all communication between the modular I/O device and the higher-level master unit on the PROFIBUS-DP. The inputs and outputs are assigned to the master in the configuration. Diagnostic information from the modules can be read out via the PAS 153 Interface in the usual way.

The PAS 153 Interface supports all input/output modules from Systeme Helmholz GmbH and numerous modules of the same type from other manufacturers.

The scope of modules supported can be extended at any time by a firmware update via the USB.



Ordering Data	Order No.
PAS 153, distributed PROFIBUS Interface (incl. CD with GSD file)	700-153-1AA03
Manual PAS 153, German/English	900-153-1AA03

Technical Data	
Dimensions (D x W x H mm)	116 x 40 x 125
Weight	Approx. 250 g
Power supply	
Voltage	DC 24 V
Current consumption	max. 625 mA
Output voltage	DC 5 V
Output current at DC 5 V	max. 1.5 A (to backplane)
PROFIBUS Interface	
Transmission rate	max. 12 Mbps, autodetection
Protocol	PROFIBUS-DP to EN 50 170
Addressrange	128 Bytes for inputs 128 Bytes for outputs
Module count	max. 16, 8 of these analog
Connection	Male, SUB-D, 9-way
Ambient temperature	0 °C ... +60 °C
Transport and storage temperature	-25 °C ... +60 °C

SAS 340, Communication Module



SAS 340, Communication Module

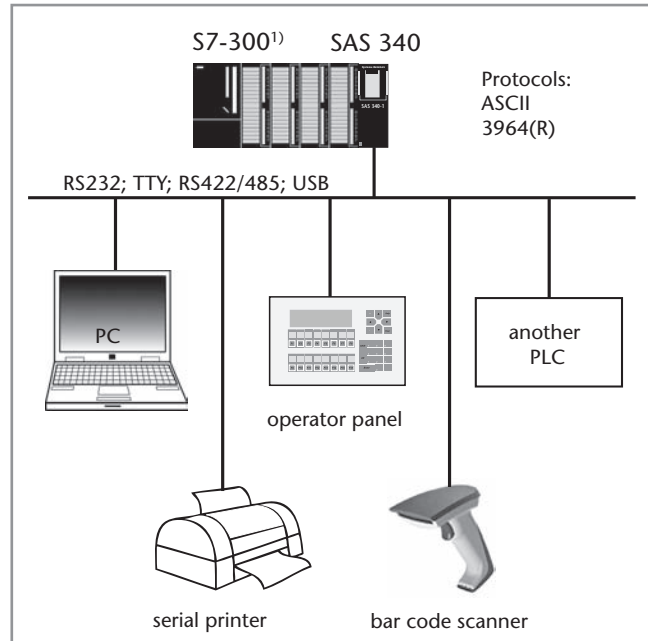

Application example for SAS 340

The SAS 340 is a serial communication module for use in S7-300¹⁾ systems. The SAS 340 permits the linking to the PLC of serial devices, such as barcode scanners, operator terminals, serial printers, PCs, PLCs of other manufacturers, and supports the ASCII and 3964R protocols.

The serial devices can be connected via RS232, TTY (20 mA), or RS422/RS485. The 9-way Sub-D socket (15-way in the case of RS422/485) with standard pin assignment is provided for connecting communicating devices.

The additional USB-device interface permits the connection of the PLC to PC systems, many of which no longer have a conventional physical port. A virtual COM port driver enables the use of software that still expects a COM port.

Extended functions, such as support for higher baud rates up to 115 kBaud, make the SAS 340 all the more versatile without any loss of compatibility.

The data handling blocks supplied enable simple and flexible integration into the PLC. The module is parameterized in the Hardware Configurator of the PLC. Extended functions (e.g. higher baud rates) can be activated with the data handling blocks without any problem.

Note

To permit a higher integration density in the cabinet, the SAS 340 is also available with 2 serial interfaces. Both interfaces can be parameterized independently and are used in the PLC.

Ordering Data	Order No.
SAS 340-1*, 1 x RS232, 1 x USB	700-340-1AH02
SAS 340-1*, 1 x TTY	700-340-1BH02
SAS 340-1*, 1 x RS422/RS485	700-340-1CH02
SAS 340-2*, 2 x RS232, 2 x USB	700-340-2AH02
SAS 340-2*, 2 x TTY	700-340-2BH02
SAS 340-2*, 2 x RS422/RS485	700-340-2CH02
*(incl. CD with data handling blocks and manual)	
Manual SAS 340, German/English	900-340-1XH02

1) S7-300 is a registered trademark of Siemens AG.

Technical Data	
Dimensions (D x W x H mm)	116 x 40 x 125
Weight	Approx. 280 g
Power supply Voltage	+5 V DC via backplane bus
Current consumption	typ. 160 mA max. 190 mA
Interfaces Type	V.24 (RS232) TTY (20 mA) RS422/RS485 (X27) USB
Transmission rate	300 Baud ... 115 kBaud
Protocol	ASCII 3964(R)
Connection	Connector, SUB-D, 9-way; 15-way (RS422/485)
Status display	6 LEDs
Ambient temperature Transport and storage temperature	0 °C ... 60 °C -25 °C ... 75 °C



SAS 341, Communication Module

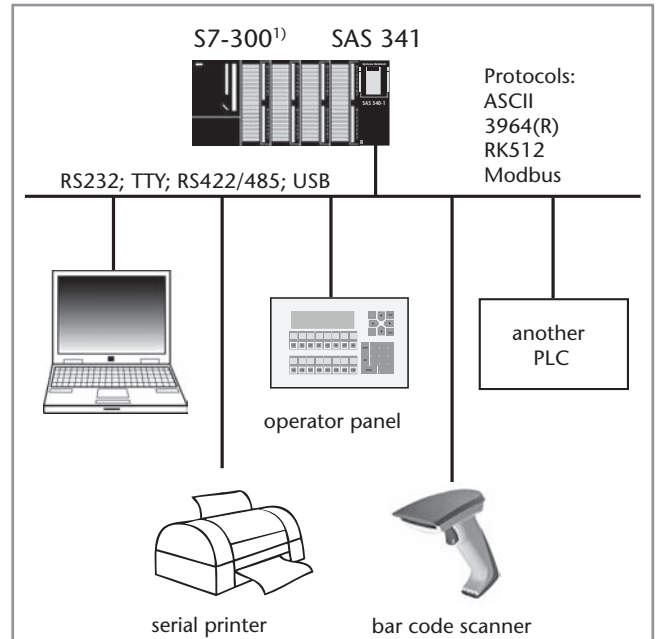

Application example for SAS 341

The SAS 341 is a serial communication module for use in S7-300¹⁾ systems. The SAS 341 permits the linking to the PLC of serial devices, such as barcode scanners, operator terminals, serial printers, PCs, PLCs of other manufacturers, and supports the ASCII, 3964R, and RK512 protocols.

The serial devices can be connected via RS232, TTY (20 mA), or RS422/RS485. The 9-way Sub-D socket (15-way in the case of RS422/485) with standard pin assignment is provided for connecting communicating devices.

The additional USB interface permits the connection of the PLC to PC systems, many of which no longer have a conventional physical port. A virtual COM port driver enables the use of software that still expects a COM port.

Extended functions, such as support for higher baud rates up to 115 kBaud, make the SAS 341 all the more versatile without any loss of compatibility.

Using the standardized RK512 computer link protocol, the linking of different types of PLC to the S7-300¹⁾ can be flexibly implemented.

The data handling blocks supplied enable simple and flexible integration into the PLC. The module is parameterized in the Hardware Configurator of the PLC.

Note

To permit a higher integration density in the cabinet, the SAS 341 is also available with 2 serial interfaces. Both interfaces can be parameterized independently and are used in the PLC.

Do you require a special protocol for your device? Just ask us!

Ordering Data	Order No.
SAS 341-1*, 1 x RS232, 1 x USB	700-341-1AH02
SAS 341-1*, 1 x TTY	700-341-1BH02
SAS 341-1*, 1 x RS422/RS485	700-341-1CH02
SAS 341-2*, 2 x RS232, 2 x USB	700-341-2AH02
SAS 341-2*, 2 x TTY	700-341-2BH02
SAS 341-2*, 2 x RS422/RS485	700-341-2CH02
*(incl. CD with data handling blocks and manual)	
Manual SAS 341, German/English	900-341-1XH02

1) S7-300 is a registered trademark of Siemens AG.

Technical Data	
Dimensions (D x W x H mm)	116 x 40 x 125
Weight	Approx. 280 g
Power supply	
Voltage	+5 V DC via backplane bus
Current consumption	typ. 160 mA max. 190 mA
Interfaces	
Type	V.24 (RS232) TTY (20 mA) RS422/RS485 (X27) USB
Transmission rate	300 Baud ... 115 kBaud
Protocol	ASCII 3964(R) RK512 Modbus Master/Slave
Connection	Connector, SUB-D, 9-way; 15-way (RS422/485)
Status display	6 LEDs
Ambient temperature	0 °C ... 60 °C
Transport and storage temperature	-25 °C ... 75 °C

SAS 341-1, with Modbus RTU Driver

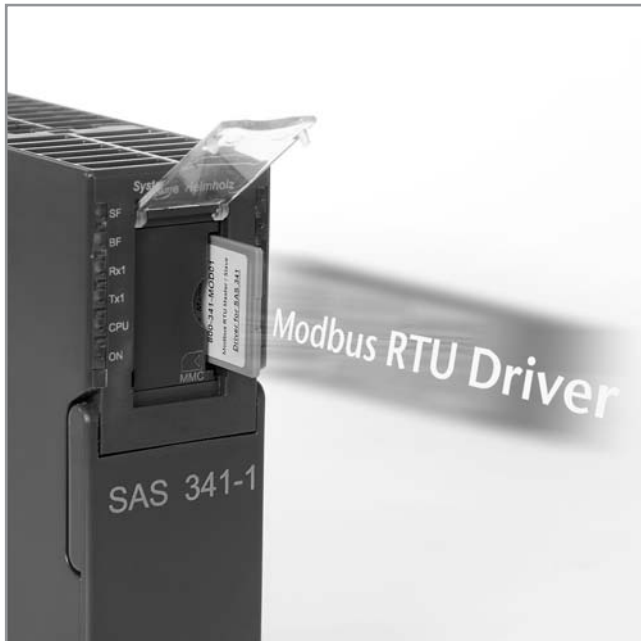

SAS 341-1 with Modbus RTU Driver

The „Modbus Master/Slave“ driver add-on facilitates communication with Modbus RTU capable devices. Using this driver the SAS 341 can work as either a Modbus RTU Master or Modbus RTU Slave.

The driver can be used with a SAS 341-1 with RS232 interface (700-341-1AH02) or with a SAS 341-1 with RS485 interface (700-341-1CH02). Point to point connections can be set up using the RS232 interface and using the RS485 interface, up to 32 users can be addressed in 2-wire half duplex mode.

When communicating with remote systems the Modbus RTU function codes 01, 02, 03, 04, 05, 06, 07, 08, 11, 12, 15 and 16 are supported.

Data transfer to and from the S7 CPU is handled block-wise via the accompanying function blocks.

Do you require a special protocol for your device? Just ask us!

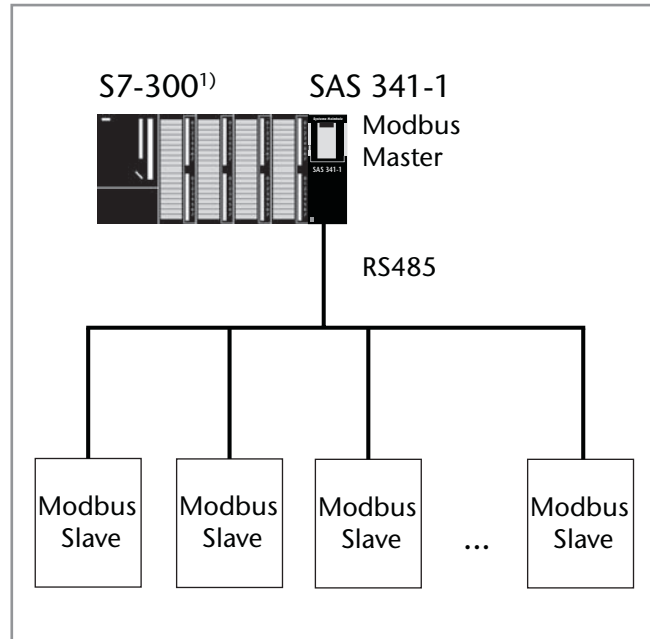

SAS 341-1 as a Modbus Master

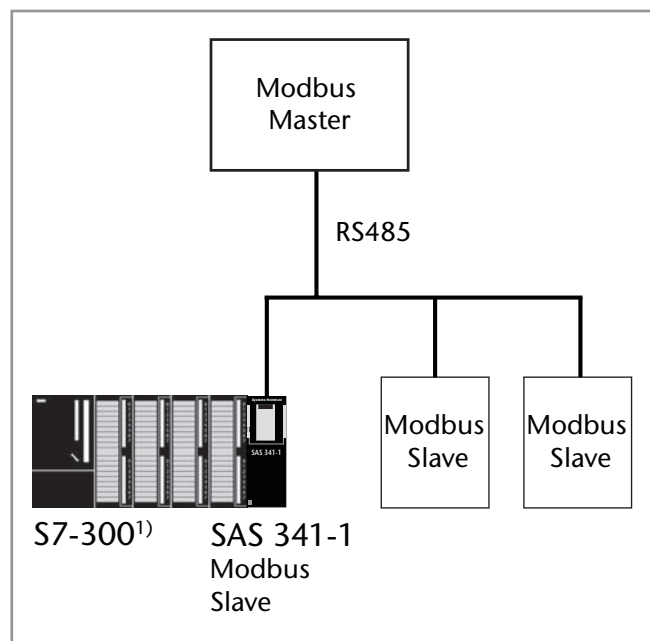

SAS 341-1 as a Modbus Slave

Ordering Data	Order No.
Modbus Master/Slave Driver for SAS 341-1 (on Micro Memory Card)	800-341-MOD01
Manual SAS 341 - Modbus Driver, German/English	900-341-MOD01



EIB 300, Communication Module for Twisted Pair EIB/KNX

The EIB 300 is a communication module for use in S7-300¹⁾ systems. It enables the connection of an EIB/KNX bus to the PLC whereby the bus is directly attached to the module. Due to the possibilities of PLC programming, complex control and monitoring functions can also be realised easily on the EIB/KNX bus. Two different operating modes are supported for flexible use of the EIB 300.

In the “object mode”, the EIB 300 is an active participant on the EIB/KNX bus with up to 240 objects whereby all object types from 1 bit to 4 bytes data size are supported. The current object values are mapped in a data module in the PLC and exchanged with each PLC cycle. In this way, value changes on the EIB side are applied in the PLC and changed values in the PLC are transmitted on the EIB/KNX bus. This can also be influenced using event and control flags targeted to the communications behaviour.

In the “telegram mode”, all telegrams transmitted on the EIB/KNX bus are transparently forwarded to the PLC and any telegrams can be sent out on the EIB/KNX bus from the PLC. This operating mode enables maximum flexibility, also in the case of complex systems or communications processes.

The management of the EIB 300 is performed in the PLC as CP module. The handling modules contained in the standard delivery enable simple integration of the EIB 300 in the PLC program. The integration of the EIB 300 in the ETS software as a new device is performed using a supplied example project. In the object mode, the objects organised there in different profiles can be configured and thus adapted to the respective application. Six coloured LEDs provide information about the current operating status of the EIB 300 and the EIB/KNX bus. The installed USB port is provided for firmware updates and in-depth diagnostics.

Features

- Access to the EIB/KNX bus directly from the PLC
- Realisation of complex control and monitoring functions using PLC programming
- Configurable object operation with up to 240 objects
- Telegram mode for the transparent EIB/KNX communication
- Easy integration and handling

Ordering Data	Order No.
EIB 300, Communication Module for Twisted Pair EIB/KNX	700-820-EIB01
Manual EIB 300, German/English	900-820-EIB01

Technical Data	
Dimensions (D x W x H mm)	116 x 40 x 125
Weight	Approx. 280 g
Power supply	
Voltage	DC +5 V via backplane bus
Current consumption	typ. 160 mA max. 190 mA
Interface	
Type	Twisted Pair EIB/KNX
Transmission rate	9600 Baud
Protocol	EIB/KNX; up to 240 objects or telegram mode
Connection	2-pin
Status display	6 LEDs
Ambient temperature	0 °C ... 60 °C
Transport and storage temperature	-25 °C ... 75 °C

1) S7-300 is a registered trademark of Siemens AG.

EIB 300, Communication Module for Twisted Pair EIB/KNX

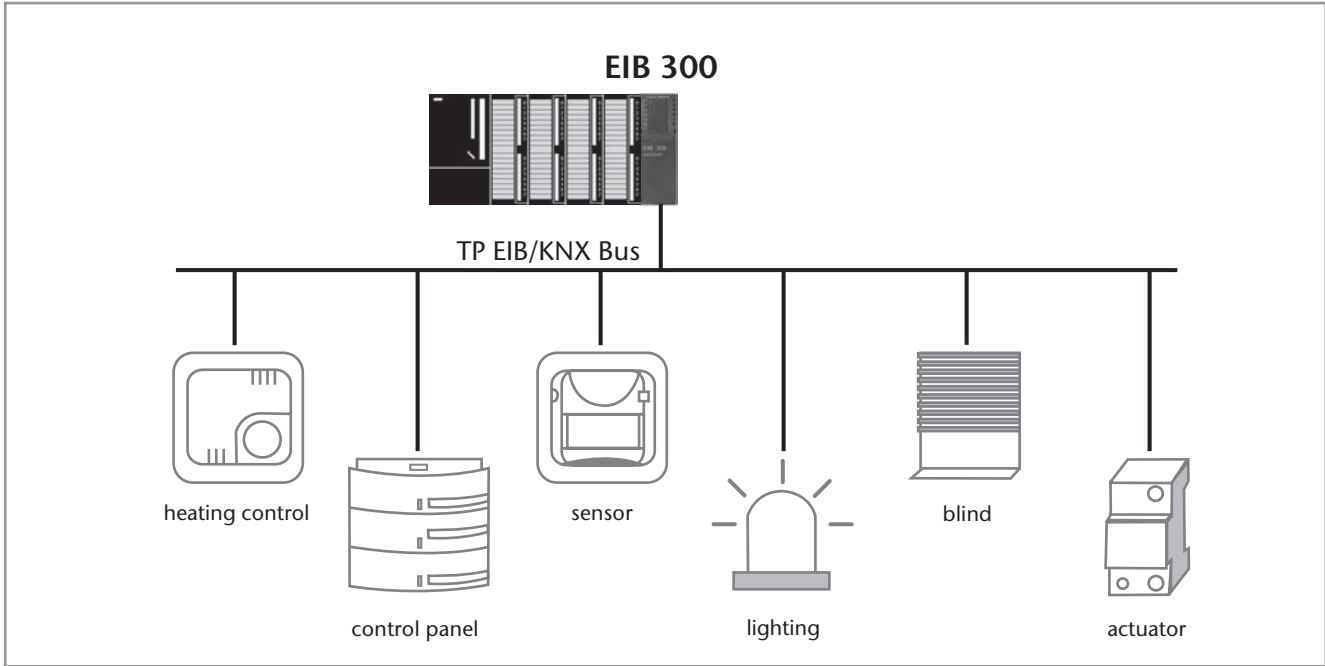

Application Example EIB 300

The screenshot shows the ETS3 software interface for configuring a PLC cabinet. The main window displays a tree view on the left and a table of objects on the right. Below the table is another window showing group addresses.

Number	Name	Object Function	Description	Group Ad...	Length	C	R	W	T	U	Data Typ
209	0	Tx Object 209		13/0/36	2 Byte	C	-	W	T	-	
210	0	Tx Object 210		13/0/69	2 Byte	C	-	W	T	-	
211	0	Tx Object 211		13/1/0	2 Byte	C	-	W	T	-	
212	Rx Object 212	2 Input Bytes @ DB890-91		1/6/0	2 Byte	C	-	W	T	U	2 byte flo.
213	Rx Object 213	2 Input Bytes @ DB892-93		1/7/1	2 Byte	C	-	W	T	U	2 byte flo.
214	Rx Object 214	2 Input Bytes @ DB894-95		1/5/10	2 Byte	C	-	W	T	U	2 byte flo.
215	Rx Object 215	2 Input Bytes @ DB896-97		1/5/20	2 Byte	C	-	W	T	U	2 byte flo.
216	Rx Object 216	2 Input Bytes @ DB898-99		4/0/0	2 Byte	C	-	W	T	U	2 byte flo.
217	Rx Object 217	2 Input Bytes @ DB8100-101		4/0/1	2 Byte	C	-	W	T	U	2 byte flo.
218	Rx Object 218	2 Input Bytes @ DB8102-103		4/0/2	2 Byte	C	-	W	T	U	2 byte flo.
219	Rx Object 219	2 Input Bytes @ DB8104-105		4/0/3	2 Byte	C	-	W	T	U	2 byte flo.
220	Rx Object 220	2 Input Bytes @ DB8106-107		4/0/4	2 Byte	C	-	W	T	U	2 byte flo.
221	Rx Object 221	2 Input Bytes @ DB8108-109		4/0/5	2 Byte	C	-	W	T	U	2 byte flo.
222	0	Tx Object 222		4/1/0	3 Byte	C	R	-	-	-	
223	0	Tx Object 223		4/1/1	3 Byte	C	R	-	-	-	
224	0	Tx Object 224		15/1/2	4 Byte	C	-	W	T	-	4 byte flo.
225	0	Tx Object 225		15/1/3	4 Byte	C	-	W	T	-	4 byte sig
226	Rx Object 226	4 Input Bytes @ DB8124-127		15/1/3	4 Byte	C	-	W	T	U	

Object	Device	Sending	C	R	W	T	U	Product
153: Ausgang 12 - Schalten	1.1.27 Halle HV A1.1 Schalt-/Jalousieaktor 16-/8fach 16A REG		C	R	W	-	-	Schalt-/Jalousieakt
36: Ausgang 2 - Schalten	1.1.44 Halle HV A1.3 Schalt-/Jalousieaktor 8fach 16A C-Last REG	5	C	-	W	-	-	Schaltaktor 8fach :
62: Ausgang 5 - Schalten	1.1.181 EG UV1 A2.2 Schalt-/Jalousieaktor 8-/4fach 16A REG	5	C	-	W	-	-	Schalt-/Jalousieakt
166: Ausgang 7 - Schalten	1.1.180 EG UV1 A2.1 Schaltaktor 8fach 16A C-Last REG	5	C	-	W	-	-	Schaltaktor 8fach :
192: Ausgang 8 - Schalten	1.1.180 EG UV1 A2.1 Schaltaktor 8fach 16A C-Last REG		C	-	W	-	-	Schaltaktor 8fach :
36: Ausgang 2 - Schalten	1.1.180 EG UV1 A2.1 Schaltaktor 8fach 16A C-Last REG		C	-	W	-	-	Schaltaktor 8fach :
10: Ausgang 1 - Schalten	1.1.174 UV 10G A3.3.1 Schalt-/Jalousieaktor 8-/4fach 16A REG	5	C	-	W	-	-	Schalt-/Jalousieakt
23: Ausgang 2 - Schalten	1.1.174 UV 10G A3.3.1 Schalt-/Jalousieaktor 8-/4fach 16A REG	5	C	-	W	-	-	Schalt-/Jalousieakt
88: Ausgang 7 - Schalten	1.1.174 UV 10G A3.3.1 Schalt-/Jalousieaktor 8-/4fach 16A REG	5	C	-	W	-	-	Schalt-/Jalousieakt
36: Ausgang 3 - Schalten	1.1.173 UV 10G A3.3 Schalt-/Jalousieaktor 8-/4fach 16A REG	5	C	-	W	-	-	Schalt-/Jalousieakt
88: Ausgang 7 - Schalten	1.1.173 UV 10G A3.3 Schalt-/Jalousieaktor 8-/4fach 16A REG	5	C	-	W	-	-	Schalt-/Jalousieakt
101: Ausgang 8 - Schalten	1.1.173 UV 10G A3.3 Schalt-/Jalousieaktor 8-/4fach 16A REG	5	C	-	W	-	-	Schalt-/Jalousieakt
114: Ausgang 9 - Schalten	1.1.170 UV 10G A3.1 Schalt-/Jalousieaktor 16-/8fach 16A REG	5	C	-	W	-	-	Schalt-/Jalousieakt
10: Ausgang 1 - Schalten	1.1.181 EG UV1 A2.2 Schalt-/Jalousieaktor 8-/4fach 16A REG		C	R	W	-	-	Schalt-/Jalousieakt
10: Ausgang 1 - Schalten	1.1.180 EG UV1 A2.1 Schaltaktor 8fach 16A C-Last REG		C	-	W	-	-	Schaltaktor 8fach :
49: Ausgang 4 - Schalten	1.1.174 UV 10G A3.3.1 Schalt-/Jalousieaktor 8-/4fach 16A REG		C	-	W	-	-	Schalt-/Jalousieakt
62: Ausgang 5 - Schalten	1.1.174 UV 10G A3.3.1 Schalt-/Jalousieaktor 8-/4fach 16A REG		C	-	W	-	-	Schalt-/Jalousieakt
75: Ausgang 6 - Schalten	1.1.174 UV 10G A3.3.1 Schalt-/Jalousieaktor 8-/4fach 16A REG		C	-	W	-	-	Schalt-/Jalousieakt

Configuration of EIB 300 at ETS3



FastPlug – Frontadapter for S7 modules

The new professional **FastPlug** Frontadapter from the Systeme Helmholtz GmbH are intended for insertion or clipping on a 16 or 32 Bit S7 Input/Output module. They are reducing the wiring effort. Through the use of prefabricated system cables, connection errors are excluded. Therefore the interface modules/transfer modules can be connected fast & safe to the S7 PLC.

The new **FastPlug** Frontadapter are available to be connected to a 16 Bit Input/Output module with a 20pin ribbon connector and a 2 x 20pin ribbon connector for 32 Bit Input/Output module.

Features

- Frontadapter for ribbon connector
- 20-way and 40-way
- Fast, safe and cost-effective wiring
- Connection errors excluded

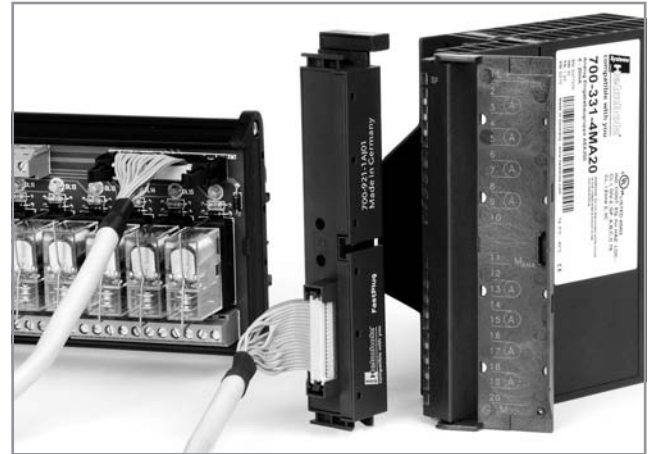

Ordering Data	Order No.
Front Connector for DEA 300	
FastPlug 20-way, S7 Frontadapter	700-921-1AJ01
FastPlug 40-way, S7 Frontadapter	700-921-1AM01
Twisted ribbon cable, unshielded, 20-way, 2 ID-connectors	
0.5 m	700-923-2BA50
1.0 m	700-923-2BB00
1.5 m	700-923-2BB50
2.0 m	700-923-2BC00
2.5 m	700-923-2BC50
3.0 m	700-923-2BD00
4.0 m	700-923-2BE00
5.0 m	700-923-2BF00

Technical Data	
Front Connector	FastPlug
Connection	1 x 20-way IDC
700-921-1AJ01	2 x 20-way IDC
700-921-1AM01	
Weight	Approx. 50 g
Dimensions (D x W x H mm)	
700-921-1AJ01	131 x 23 x 31
700-921-1AM01	116 x 22 x 30
Voltage	Max. 48 V AC/DC between any terminals
Current consumption	Max. 600 mA per terminal
Ambient temperature	0 °C ... +60 °C
Transport and storage temperature	-25 °C ... +80 °C
Relative humidity	max. 75 % at +25 °C



Front Connectors, 20-way and 40-way with screw contacts

Front Connector with screw contacts

The 20-way and 40-way front connector from the Systeme Helmholz GmbH uses time-tested screw contacts. The front connector permits simple connection of sensors and actuators to input/output modules of Systeme Helmholz GmbH or other manufacturers. The wiring can thus be retained even in the event of module replacement.

Front Connector, 40-way with **EasyConnect**[®] technology**Front Connector with EasyConnect[®] technology**

The 40-way front connector from the Systeme Helmholz GmbH is supplied with **EasyConnect**[®] technology. The connector is quickly wired up simply by opening and closing the spring-loaded terminal by turning the screw head (180° counterclockwise to open, clockwise to close). That not only saves the user money but also installation time.

No wire end ferrule is needed!

The flat design permits optimum closing of the module front cover even with the connector fully wired.

Technical Data	
Front Connector 20-way	
Connection	Screw-type terminals
Connectable cables W/o wire end ferrule	Flexible, solid 0.25 - 1.5 mm ²
Strip length	6 mm
Max. tightening torque	0.5 Nm
Weight	Approx. 60 g
Current at 60 °C	3 A
Voltage	230 V AC
Ambient temperature	0 °C ... +60 °C
Transport and storage temperature	-25 °C ... +80 °C
Relative humidity max.	75% at +25 °C
Front Connector 40-way	
Connection	Screw-type terminals
Connectable cables W/o wire end ferrule	Flexible, solid 0.125 - 1.5 mm ²
Strip length	6 - 8 mm
Max. tightening torque	0.5 Nm
Weight	Approx. 120 g
Current at 60 °C	3 A
Voltage	230 V AC
Ambient temperature	0 °C ... +60 °C
Transport and storage temperature	-25 °C ... +80 °C
Relative humidity max.	75% at +25 °C

Technical Data	
Front Connector 40-way	
Connection	EasyConnect [®]
Connectable cables	Flexible 0.34 - 1 mm ²
Strip length	8 - 10 mm
Weight	Approx. 70 g
Current at 60 °C	3 A
Voltage	230 V AC
Ambient temperature	0 °C ... +60 °C
Transport and storage temperature	-25 °C ... +80 °C
Relative humidity max.	75% at +25 °C

Ordering Data	Order No.
Front Connector for DEA 300	
20-way with screw contacts	700-392-1AJ10
40-way with screw contacts	700-392-1AM01
40-way with EasyConnect [®] technology	700-392-1AM10



Front Connectors, 20-way and 40-way with spring contacts

Front Connector with spring contacts

The 20-way and 40-way front connector from the Systeme Helmholtz GmbH uses spring contacts. The front connector permits simple connection of sensors and actuators to input/output modules of Systeme Helmholtz GmbH or other manufacturers. The wiring can thus be retained even in the event of module replacement.



Ready-wired Front Connectors

Ready-wired Front Connector

The Ready-wired front connectors are available for easy connection of sensors and actuators to input/output modules of Systeme Helmholtz GmbH.

The cabling can be kept when modules are replaced.

Technical Data

Front Connector 20-way	
Connection type	Spring contacts
Connectable cables	Flexible, solid 0.34 - 1.5 mm ²
Insulation stripping length	8 mm
Weight	Approx. 50 g
Current at 60 °C	3 A
Voltage	230 V AC
Ambient temperature	0 °C ... +60 °C
Transport and storage temperature	-25 °C ... +80 °C
Relative humidity	max. 75 % at +25 °C
Front Connector 40-way	
Connection type	Spring contacts
Connectable cables	Flexible, solid 0.34 - 1.5 mm ²
Insulation stripping length	8 mm
Weight	Approx. 70 g
Current at 60 °C	3 A
Voltage	230 V AC
Ambient temperature	0 °C ... +60 °C
Transport and storage temperature	-25 °C ... +80 °C
Relative humidity	max. 75 % at +25 °C

Ordering Data

Ordering Data	Order No.
Front Connector for DEA 300	
20-way with spring contacts	700-392-1BJ01
40-way with spring contacts	700-392-1BM01

Ordering Data

Ordering Data	Order No.
Ready-wired Front Connectors¹⁾	
DEA 300	
for screw contacts, 20-way, 2 m	700-392-1AJ10A
for screw contacts, 20-way, 3 m	700-392-1AJ10B
for screw contacts, 20-way, 5 m	700-392-1AJ10C
for EasyConnect [®] connection, 40-way, 2 m	700-392-1AM10A
for EasyConnect [®] connection, 40-way, 3 m	700-392-1AM10B
for EasyConnect [®] connection, 40-way, 5 m	700-392-1AM10C
for spring contacts, 20-way, 2 m	700-392-1BJ01A
for spring contacts, 20-way, 3 m	700-392-1BJ01B
for spring contacts, 20-way, 5 m	700-392-1BJ01C
for spring contacts, 40-way, 2 m	700-392-1BM01A
for spring contacts, 40-way, 3 m	700-392-1BM01B
for spring contacts, 40-way, 5 m	700-392-1BM01C

1) Strands 0.5 mm² blue (RAL 5010); Labeling as on connector

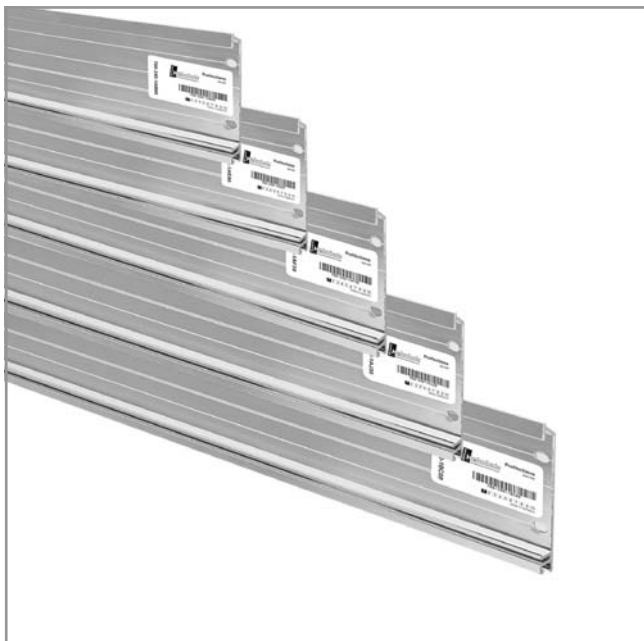

Mounting rail



Mounting rail adapter for DIN rail

For all DEA and AEA etc., we offer the mechanical module subrack for the S7-300¹⁾ as an accessory in various lengths.

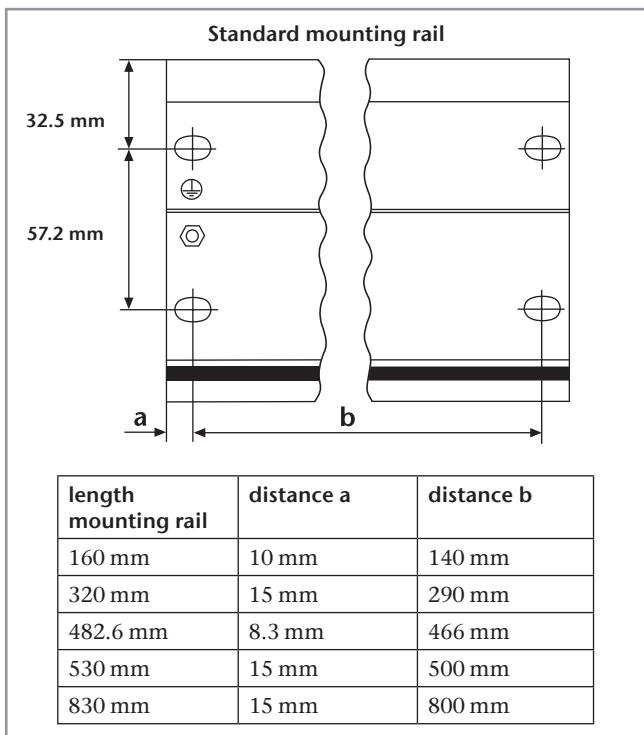

Ordering Data	Order No.
Mounting rail	
length 160 mm	700-390-1AB60
length 320 mm	700-390-1SO01
length 482 mm	700-390-1AE80
length 530 mm	700-390-1AF30
length 830 mm	700-390-1AJ30
length 2000 mm	700-390-1BC00

Ordering Data	Order No.
Mounting rail adapter for DIN rail	700-390-6BA01

1) S7-300 is a registered trademark of Siemens AG.



CAN Bus

CAN Bus Modules for S7-300¹⁾, S7-400¹⁾

DP/CAN Coupler

CAN Bridge

CAN Bus Connector

¹⁾ S7-300 and S7-400 are registered trademarks of Siemens AG.

CAN 300 PRO, Communication Module



CAN 300 PRO, communication module

The CAN 300 PRO module of Systeme Helmholtz GmbH for use in an S7-300¹⁾ from Siemens permits connection of CAN stations with the programmable controller.

The module can be slotted either in the central controller or in the expansion unit.

The CAN 300 PRO module supports CAN 2.0A (11 Bit) and CAN 2.0B (29 Bit) frames with a freely selectable baud rate of 10 kbps to 1 Mbps.

The CAN 300 PRO module can send and receive CAN frames in Layer 2 operating mode. The data of the CANopen[®] slaves can be processed as a process image in CANopen[®] Master operating mode in the PLC. Applications as a CANopen[®] Slave is also possible. Application examples are provided for standard applications including motor control with CANopen[®]. Data handling blocks for the SAE J1939 protocol are also available.

The CAN 300 PRO module contains 16 freely settable timers. Each timer can trigger a freely programmable CAN telegram. That way, it is easy to implement the synchronous protocols in common use in drive and servo systems using the CAN 300 PRO module.

The DIP switch for setting the baud rate and the station address facilitate commissioning. An optional micro memory card stores the project so that the parameterization or the module is quickly replaced during servicing.

6 LEDs indicate the operating status of the module. A USB interface is available for diagnostics and parameterization tasks.

The CAN 300 PRO also works in the extended ambient temperature range of -25 °C to +60 °C.

A USB cable is included.

Ordering Data	Order No.
CAN 300 PRO, communication module (incl. USB programming cable)	700-600-CAN12
Micro Memory Card, 256 kByte	700-953-8LH30
Manual CAN 300 PRO, German/English	900-600-CAN12
CAN Training Course (see page 111)	400-600-CAN01

1) S7-300 is a registered trademark of Siemens AG

Features

- Layer 2, 11 Bit and 29 Bit (CAN 2.0 A/B)
- CANopen[®] Master on the module
- DIP switch for address + baud rate
- Micro Memory Card for saving a project (optional)
- USB Interface for parameterization and diagnostics
- Extensive CAN Bus diagnostics
- Can also be used as a CANopen[®] slave
- Extended ambient temperature range

CAN
connected

CANopen[®]

Member of: **cia**[®]

Note

On page 97 you will find information about the parameterization software CANParam and about the data handling blocks for the PLC.

When first used, data handling blocks are required for the PLC.

Technical Data	
Dimensions (D x W x H mm)	116 x 40 x 125
Weight	Approx. 280 g
Power supply Voltage	+5 V DC via backplane bus
Current consumption	typ. 160 mA max. 190 mA
CAN interfaces Type	ISO/DIN 11898-2 CAN High Speed physical Layer
Transmission rate	10 kbps to 1 Mbps
Protocol	CAN 2.0A (11 Bit) CAN 2.0B (29 Bit) CANopen [®] Master CANopen [®] Slave SAE J1939 DeviceNet Slave (on request)
Connection	Connector, SUB-D, 9-way
Status display	6 LEDs
Configuration interfaces Type	USB 1.1
Connection	USB-B female connector
Ambient temperature	-25 °C ... 60 °C
Transport and storage temperature	-25 °C ... 75 °C

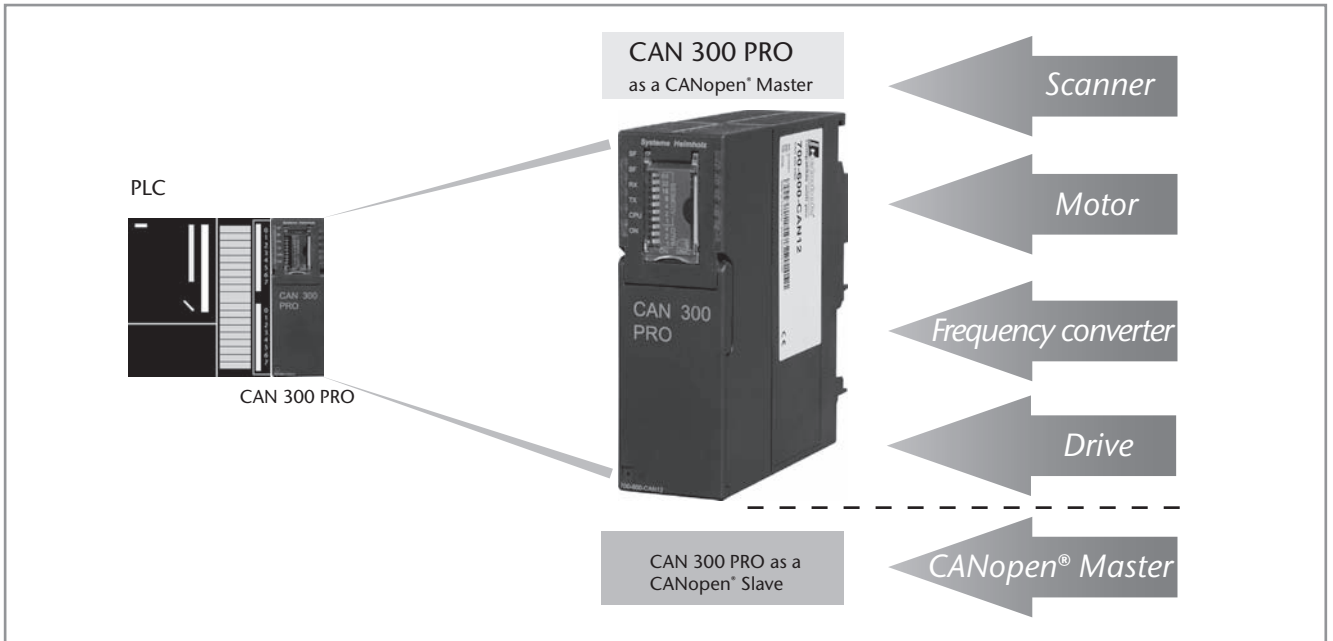

Application Example CAN 300 PRO as a CANopen[®] Master/Slave

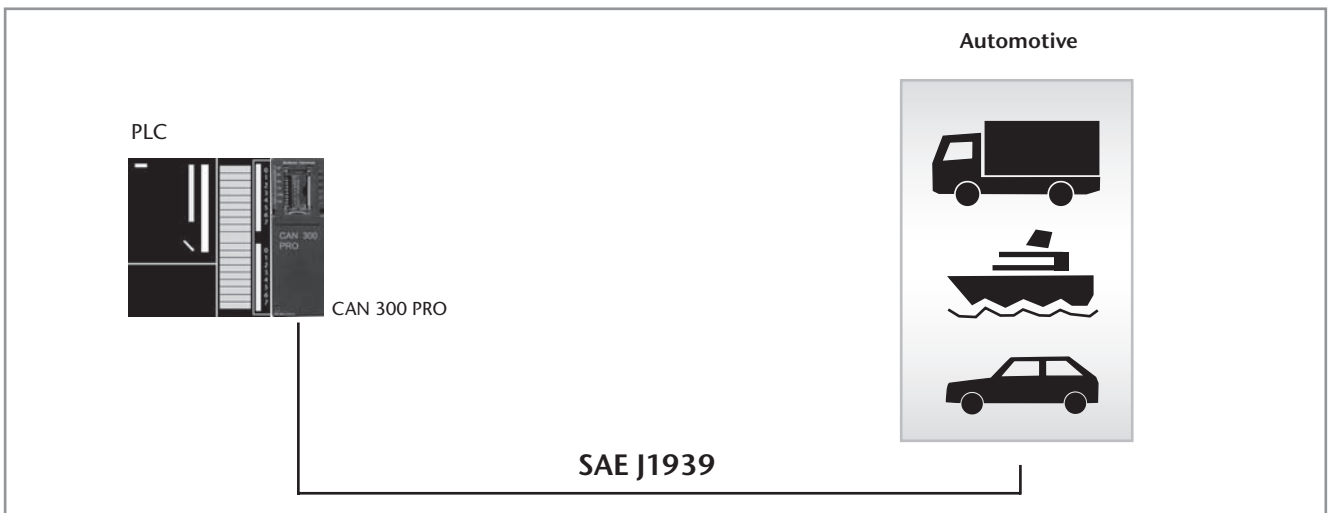

Application Example CAN 300 PRO SAE J1939 Protocol

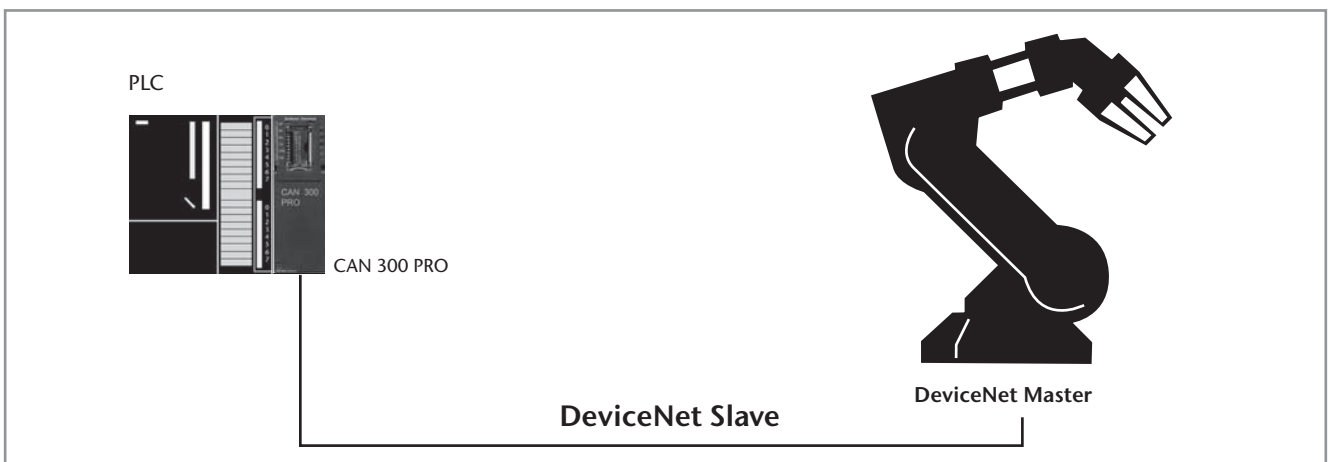

Application Example CAN 300 PRO as a DeviceNet Slave

CAN 400, Communication Module



CAN 400, communication module

The CAN 400 module from the Systeme Helmholtz GmbH for use in a S7-400¹⁾ from Siemens permits connection of CAN stations with the programmable controller. The module can be slotted either into the central controller or into the expansion unit. The CAN 400 modules support both CAN 2.0A (11 Bit) and CAN 2.0B (29 Bit) frames with a free selectable baud rate of 10 kbps to 1 Mbps.

The CAN 400 module can also be run as Layer 2, CANopen[®] Master or CANopen[®] Slave.

The CAN 400 module contains the scripts "Power On", "Stop -> Run", "Run-> Stop", "Power Off". IDs relevant to the programmable controller can be prefiltered using a 5-level acceptance mask. In CAN 400 modules, 16 free settable timers up to a resolution of 1ms are available. Each timer can trigger a free programmable CAN frame. In that way, it is simple to implement synchronous protocols commonly used in drive and servo control using the CAN 400 module.

Note

Information about software and handling blocks is available on page 97.

When first used, data handling blocks are required for the PLC.

Ordering Data	Order No.
CAN 400-1, Communication module with 1 CAN interface	700-640-CAN11
CAN 400-2, Communication module with 2 CAN interfaces	700-640-CAN21
Manual CAN 400, German/English	900-640-CAN21
CAN Training Course (see page 111)	400-600-CAN01

1) S7-400 is a registered trademark of Siemens AG

Features

- Layer 2, 11 Bit and 29 Bit (CAN 2.0 A/B)
- DIP switch for address + baud rate
- USB Interface for parameterization and diagnostics
- Extensive CAN Bus diagnostics
- Can also be used as a CANopen[®] master or CANopen[®] slave

CAN
connected

CANopen[®]

Member of: **cia**[®]

Technical Data		
	CAN 400-1	CAN 400-2
Dimensions (D x W x H mm)	290 x 210 x 25	290 x 210 x 25
Weight	Approx. 900 g	Approx. 900 g
Power supply		
Voltage	DC +5 V via backplane bus	DC +5 V via backplane bus
Current consumption	560 mA	600 mA
CAN interfaces		
Number	1	2
Type	ISO/DIN 11898-2 CAN High Speed physical Layer	ISO/DIN 11898-2 CAN High Speed physical Layer
Transmission rate	10 kbps to 1 Mbps	10 kbps to 1 Mbps
Protocol	CAN 2.0A (11 Bit) CAN 2.0B (29 Bit) CANopen [®] Master CANopen [®] Slave SAE J1939	CAN 2.0A (11 Bit) CAN 2.0B (29 Bit) CANopen [®] Master CANopen [®] Slave SAE J1939
Connection	SUB-D connector, 9-way	2 x SUB-D connector, 9-way
Status signal	6 LEDs	10 LEDs
Configuration interfaces		
Type	USB 1.1	USB 1.1
Connection	USB B-female	USB B-female
Ambient temperature	0 °C ... 60 °C	0 °C ... 60 °C
Transport and storage temperatur	-25 °C ... 75 °C	-25 °C ... 75 °C

Parameterization Tool CANParam

The CAN modules are parameterized on the PC using the CAN-Param parameterization tool (contained in the 800-600-1AA11 software package). That makes setting the communication parameters easy. The parameterization of a module can be stored in a project on the PC.

The CAN modules support both the protocol format CAN 2.0A (11 Bit) and CAN 2.0B (29 Bit).

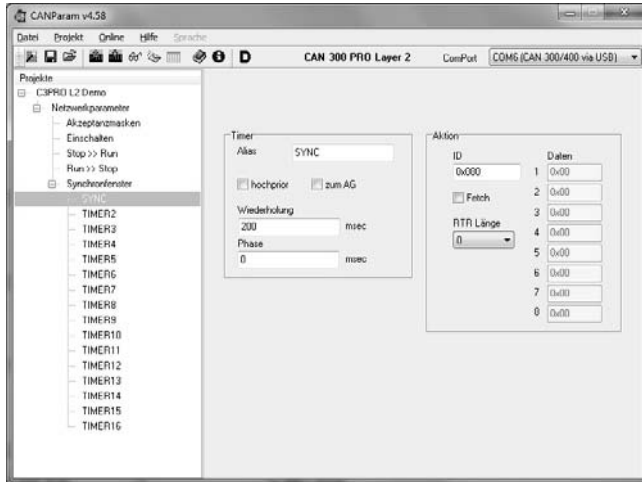

The CAN modules contain acceptance masks. These masks can be used to enable or disable various telegram IDs for reception. Express masks filter high-priority CAN telegrams so that they can be forwarded directly to the PLC.

For time-dependent events, such as the SYNC telegram in the case of CANopen®, up to 16 timers are available in the CAN modules with a resolution up to 1ms. Each timer can transmit any CAN telegram. The timers can be started, stopped, and changed from the PLC.

The timer 0 can also be used for synchronized transmission of CAN telegrams. It defines the time window in which all data will be transmitted synchronously.

CAN telegrams can be transmitted or timers started via freely programmable scripts on certain events such as “Power ON” or “PLC Stop -> Run”.

An integrated diagnostic function facilitates troubleshooting on commissioning of the module.

For CAN 300 PRO's CANopen® Master Function it's both possible to define the masters properties as to parameterize the slaves existing on the CAN bus.

In order to facilitate projection EDS-files can be read from CANopen® Slaves by CANParam Software.

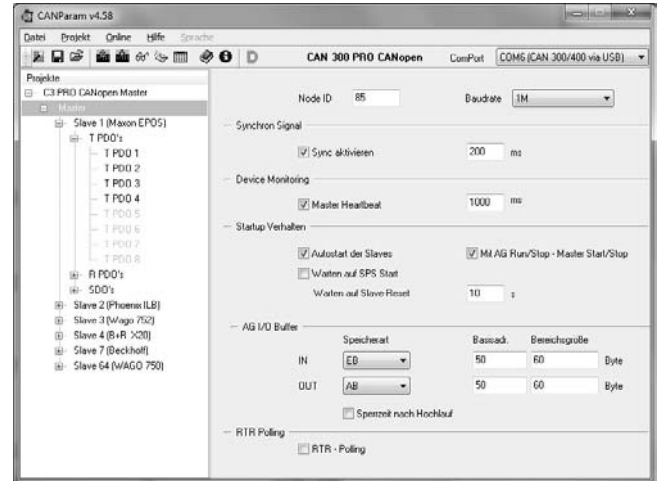

Handling blocks

The CAN module is entered in the hardware configuration of the programming software as a CP- module (CAN 300, CAN 300 PRO) or an FM-module (CAN 400) and addressed in the STEP¹⁷ / TIA Portal¹¹ program via handling blocks.

For the CAN modules, handling blocks are available for layer 2 communication and for CANopen® Master (DS301 V4). If CAN modules are to be used as a CANopen® Slave, data handling functions are available for the profiles DS401 (IO modules) and DS420 (Corrugator). Further profiles can be set up on request.

Function scope of layer 2 data handling function:

- Transmit CAN telegram
- Read CAN telegram from the module
- Transmit CAN telegram to a timer
- Timer start/stop
- module reset

Various CAN protocols in 11 Bit or 29 Bit mode can be implemented with the handling blocks for layer 2.

Function scope of the CANopen® Master data handling function:

- Read SDO
- Transmit SDO
- SDO segmented download
- SDO segmented upload
- Spontaneous receive (NMT,PDO, Emergency)
- Transmit PDO
- Request PDO
- Nodeguarding/Heartbeat
- Network management

Application examples for controlling drives according to the DS402 profile are also supplied.

Furthermore handling blocks are available to utilize CAN 300 PRO as DeviceNet Slave.

Ordering Data	Order No.
Handling blocks for CAN CD with parameterization software “CANParam”, handling blocks “Layer 2”, “CANopen®” and “SAE J1939”	800-600-1AA11
CANopen® Slave handling blocks Devicenet Slave handling blocks	on request on request
CAN Trainig Course (see page 111)	400-600-CAN01

1) STEP and TIA Portal are registered trademarks of Siemens AG.

DP/CAN Coupler CANopen®



DP/CAN Coupler CANopen®

The DP/CAN coupler links CANopen® devices into a PROFIBUS-DP network.

The DP/CAN coupler is a full-function CANopen® Master. It supports network management, SYNC telegrams and nodelocking for monitoring the nodes.

On the PROFIBUS-DP, the DP/CAN coupler is a normal node. The IO data of the CANopen® nodes are placed on the PROFIBUS in a transparent and freely configurable way.

The DP/CAN coupler is linked into the hardware configuration software via a GSD file and can be configured completely there. Further tools are not necessary.

On the PROFIBUS all standard baud rates up to 12 Mbps are supported; on the CAN bus, up to 1 Mbps.

The PROFIBUS address is set via a DIP switch.

Parameterization of the CANopen® nodes via SDO telegrams and management of emergency messages is also possible.

Alternatively the DP/CAN coupler can also be used as a CAN Layer 2 device on the CAN bus. This enables the connection of customer-specific CAN protocols via the PROFIBUS, too.

The DP/CAN coupler is intended for mounting on the DIN sectional rail and requires a 24 V power supply. Because of its small width it fits even into the smallest cabinets.

Features

- Up to 15 CANopen® participants
- Up to 1 Mbps CAN baud rate
- Up to 12 Mbps PROFIBUS-DP
- Address setting via DP switch
- Simple configuration via GSD file
- CANopen® Master and CAN Layer 2 possible
- Address and function settable via dip switches
- 3 status LEDs
- Extended ambient temperature range

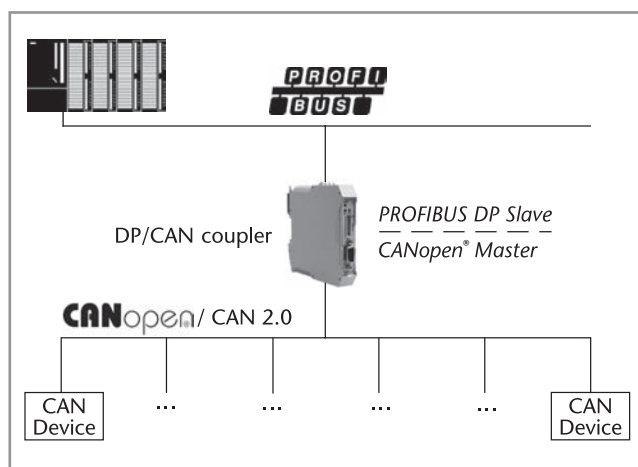

Application example DP/CAN Coupler CANopen®

Technical Data	
Dimensions (D x W x H mm)	114 x 18 x 108
Weight	Approx. 110 g
Power supply	
Voltage	24 V
Current consumption	Approx. 180 mA
CAN interfaces	
Type	ISO/DIN 11898-2 CAN High Speed physical Layer
Transmission rate	10 kbps to 1 Mbps
Protocol	CANopen® Master CAN 2.0A (11 Bit)
Connection	Clamp, 3-way
Status display	3 LEDs
Configuration interfaces	
Transmission rate	max. 12 Mbps, autodetection
Protocol	PROFIBUS-DP to EN 50 170
Connection	SUB-D female, 9-way
Ambient temperature	-25 °C ... 70 °C
Transport and storage temperature	-40 °C ... 75 °C
Relative humidity	max. 80% at +20 °C, non- condensing
Degree of protection	IP 20

Ordering Data	Order No.
DP/CAN Coupler CANopen® (incl. manual, CD with software)	700-650-CAN01



DP/CAN Coupler Layer 2

The DP/CAN coupler layer 2 of Systeme Helmholtz GmbH allows you to connect any number of CAN nodes to the PROFIBUS-DP. The DP/CAN coupler layer 2 must be parameterized in the hardware configurator as a PROFIBUS node. The GSD files required for this purpose are supplied with the device.

The PROFIBUS side is configured as a DP slave. The interfaces meets EN 50170 and are electrically isolated. Baud rates of 9.6 kbps to 12 Mbps are automatically detected. The size of the input and output information is up to 312 Bytes.

The CAN bus interface meets ISO/DIN 11898-2 and is electrically isolated.

The DP/CAN coupler can send and receive any number of CAN messages. Messages can be defined with a fixed identifier, whose data are always visible in the PROFIBUS as an I/O image. Alternatively the DP/CAN coupler layer 2 can be equipped with a receive buffer for any number of CAN messages.

Features

- Up to 1 Mbps CAN baud rate
- Up to 12 Mbps PROFIBUS-DP
- Address setting via DP switch
- Simple configuration via GSD file
- Any protocols possible via layer 2
- CAN 2.0 A (11Bit)
- CAN 2.0 B (29 Bit)
- Timer for cyclic telegrams
- 3 Status LEDs
- Extended ambient temperature range

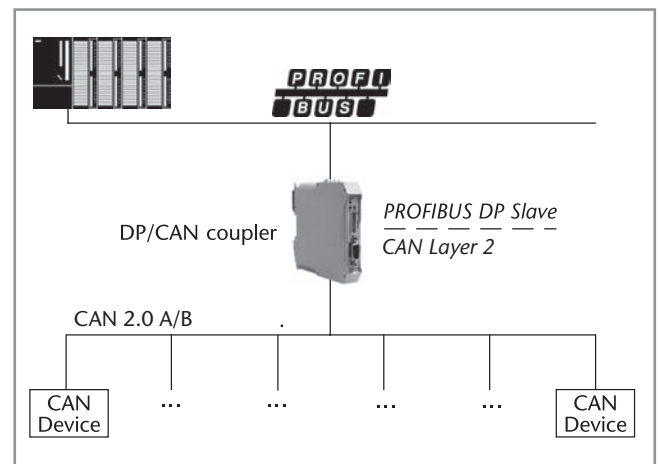

Application example DP/CAN Coupler Layer 2

Technical Data

Dimensions (D x W x H mm)	114 x 18 x 108
Weight	Approx. 110 g
Power supply	
Voltage	24 V
Current consumption	Approx. 180 mA
CAN interfaces	
Type	ISO/DIN 11898 -2 CAN High Speed physical Layer
Transmission rate	10 kbps to 1 Mbps
Protocol	CAN 2.0A (11 Bit) / CAN 2.0B (29 Bit)
Connection	Clamp, 3-way
Status display	3 LEDs
Configuration interfaces	
Transmission rate	max. 12 Mbps, autodetection
Protocol	PROFIBUS-DP to EN 50 170
Connection	SUB-D female, 9-way
Ambient temperature	-25 °C ... 70 °C
Transport and storage temperature	-40 °C ... 75 °C
Relative humidity	max. 80% at +20 °C, non- condensing
Degree of protection	IP 20

Ordering Data

DP/CAN Coupler Layer 2
(incl. manual, CD with software)

Order No.

700-651-CAN01

CAN Bus Connector

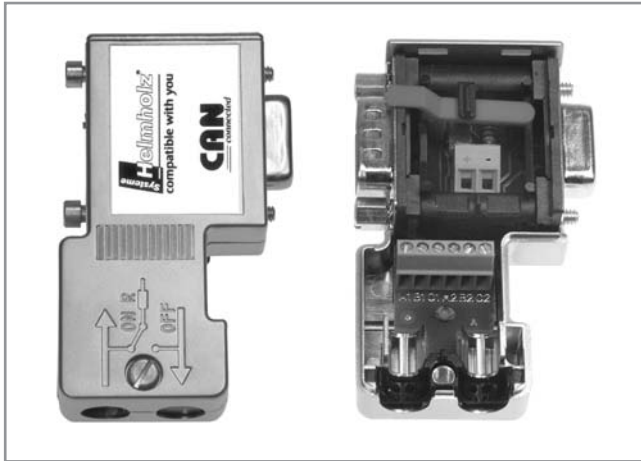

CAN bus connector, 90° cable outlet



CAN bus connector, axial

The bus connectors for CAN bus are used to connect a CAN bus station to the CAN bus cable. The connector is quickly mounted and has integrated, connectable terminating resistors. The Systeme Helmholtz GmbH offers the bus connector with a vertical outgoing cable and for transmission rates up to 1 Mbps. The bus connector is plugged directly onto the CAN bus interface (SUB-D connector, 9-way) of the CAN bus stations. The CAN bus cables are connected using 6-way screw terminals. Using a slide switch, you can set whether the connector is to be used as a node or segment end. The switch can also be operated when the connector is installed. The setting can be clearly seen. The connector must be operated in node setting ("OFF") when the incoming bus and the outgoing bus are to be interconnected. The terminating resistors are then bypassed. The connector must be set as a segment end ("ON"), on the first and last (extreme) stations of the segment. In that case the terminating resistors are connected on the incoming bus, the outgoing bus is disconnected. The bus connectors for CAN are also available with axial cable outlet and 24 V for user supply.

Features

- 24 V for user supply (only for 90°)
- Metalized housing
- No loosable parts
- 90° and axial cable outlet available
- Small housing

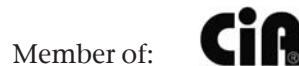

Ordering Data	Order No.
CAN Bus Connector 90° without additional connection jack	700-690-1BA12
CAN Bus Connector 90° with additional connection jack	700-690-1BB12
CAN Bus Connector axial	700-690-0CA12

Technical Data	
Connection jack	Yes
Order No. 700-690-1BB12	No
Order No. 700-690-1BA12	No
Order No. 700-690-0CA12	No
Dimensions (D x W x H mm)	
700-690-1BB12/690-1BA12	64 x 40 x 17
700-690-0CA12	67.5 x 35 x 17
Weight	Approx. 40 g
Terminating resistor	Resistance 120 Ω; integrated and connectable with slide switch
Transmission rate	max. 1 Mbps
Interfaces	
CAN bus station	SUB-D connector, 9-way
CAN bus cable	6 terminals for wires up to 0.5 mm ²
Max. outside diameter	8.0 mm
Ambient temperature	0 °C ... +60 °C
Transport and storage temperature	-25 °C ... +75 °C
Relative humidity	max. 75 % at +25 °C
Degree of protection	IP 20



CAN Bridge, connecting CAN networks

CAN bus systems have become widely distributed in automation technology and are also being used more and more frequently in complex applications.

The CAN Bridge from Systeme Helmholtz GmbH enables the coupling of two CAN networks of the same or different types. Thereby, the CAN Bridge can operate both as message repeater for increasing the network expansion as well as connecting different CAN networks with each other. It is not significant thereby whether the CAN networks have different baud rates or operate with different protocols, e.g. CANopen® and a proprietary protocol.

A flexible, configurable filtering logic can adopt freely selectable identifiers and implement on the other network. The CAN messages are forwarded to the respective other network according to the Store-Forward principle and sent out again.

Using the CAN Bridge, the CAN networks are both physically decoupled (electrical isolation) as well as reducing the bus load on both CAN networks. The CAN Bridge enables a flexible design of the network topology; star and tree structures can also be implemented as expanded line structures.

The CAN Bridge can be configured for simple applications using the two rotary encoding switches. In the case of more complex applications, the filtering and forwarding of the CAN telegrams can be flexibly adjusted using the supplied CAN Bridge configuration software. Up to 256 range filters and up to 4 bit filters for address filtering are available. The configuration is read in using a USB port and can also be read out again.

The CAN Bridge operates both in 11-bit as well as 29-bit mode and can communicate with baud rates of 10 Kbaud up to 1 Mbaud. It has a powerful micro controller which can also operate at the highest data rates and bus loads without loss of the messages. 5 LEDs signal the status of the device and the connected CAN networks.

Ordering Data	Order No.
CAN Bridge 2 x CAN bus interfaces (incl. software and USB programming cable)	700-660-2AA01

Features

- Increasing the network expansion
- Connecting different CAN networks with each other (different baud rates/different protocols)
- Physical decoupling (electrical isolation)
- Reduces the bus load on both CAN networks
- Autobaud detection
- Easy configuration mode
- Can be used with CAN 2.0A & 2.0B, CANopen®, DeviceNet, SAE J1939
- DIN rail mounting

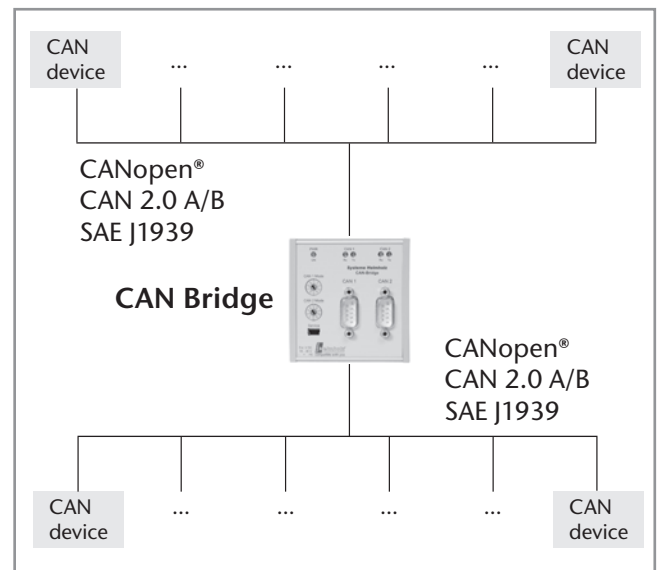

Technical Data

Dimensions in mm (D x W x H)	31 x 74 x 75
Weight	Approx. 130 g
Power supply	
Voltage	18 - 30 V DC
Current consumption	typ. 35 mA max. 60 mA
CAN interfaces	
Type	2 x ISO/DIN 11898-2 CAN High Speed physical Layer
Transmission rate	10 kbps up to 1 Mbps
Protocol	CAN 2.0A (11 Bit) CAN 2.0B (29 Bit) CANopen® SAE J1939 DeviceNet
Connection	2 x Connector, SUB-D, 9-way
Status display	5 LEDs
Configuration interfaces	
Type	USB 1.1
Connection	Mini USB socket
Ambient temperature	-25 °C ... 60 °C
Transport and storage temperature	-25 °C ... 75 °C



Interface Converters

Programming Adapter
RK512 and HMI Adapter
S5 Interface Converters



SSW7, MPI-Programming Adapter

Features

- Programming and visualization
- Transmission rate up to 115 kBaud
- MPI up to 187.5 kbps
- Power supply via programming device or via external 24 V supply

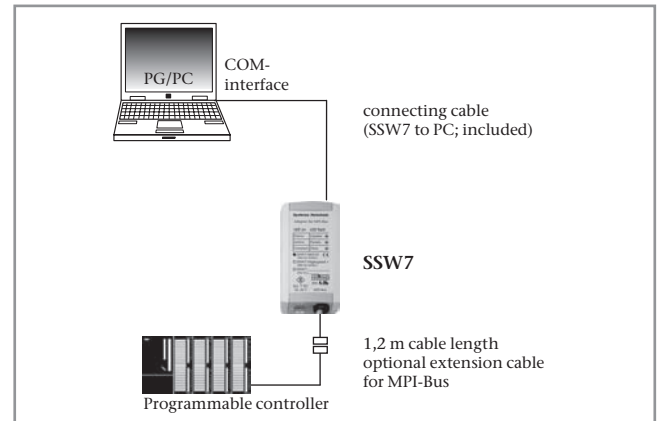

Application example for SSW7

The SSW7 permits connection of a PC or laptop with programming software to programmable controllers via any standard COM port. The RS232 interface of the SSW7 has automatic baud rate detection for adaptation to the set baud rate (between 9.6 to 115 kbps). The MPI interface operates with 187.5 kbps or 19.2 kbps. The SSW7 receives its voltage supply from the CPU via the MPI bus. With an optional 24 V connection it can be used anywhere else in the system. With the included speed-up tool you can attain the max. transmission rate of the SSW7 with every programming software.

Accessory-Note

By using SHTools software parameterization and diagnostic functions are possible. For firmware update a free download of the latest SHTools version is available on our website www.helmholz.com.

Technical Data	
Dimensions (D x W x H mm)	105 x 53 x 29
Weight	Approx. 180 g
Supply voltage	+24 V ±25 % from PLC or extern
Current consumption	typ. 30 mA max. 45 mA
MPI-Interface	
Type	RS485
Transmission rate	19.2 or 187.5 kbps
Cable connector	SUB-D, 9-way
Communication interface	
Type	RS232/RS422
Transmission type	Serial asynchronous
Transmission rate	19.2 kbps to 115.2 kbps
Parity	odd
Data format	8 Bit
Protocols	PC <-> S7
Connection	Connector, SUB-D, 9-way
Degree of protection	IP 20

Ordering Data	Order No.
MPI-Adapter SSW7, RS232 (incl. 3 m programming cable, manual, CD with software)	700-751-1VK21
SSW7, RS422 (incl. manual, CD with software)	700-752-1VK21
DIN rail adapter short Power Plug (optional)	700-751-HSH01 700-751-SNT01

From STEP¹⁾ 7 version 5.5 SP2 Siemens no longer supports serial COM ports when using Windows 7²⁾ 64 bit. The TIA Portal¹⁾ also supports no COM ports - no matter what operating system is installed.

1) STEP and TIA Portal are registered trademarks of Siemens AG.
2) Windows 7 is a registered trademark of Microsoft Corporation.



SSW7-USB, MPI-Programming Adapter USB

The SSW7-USB permits conversion from a USB interface to the MPI bus for programming software or visualization. The SSW7 has a 1.2 m long MPI connecting cable, which can be directly plugged into the CPU socket of the programmable controller or at any other point in the MPI network. The housing of the SSW7-USB contains a type "B" USB socket. The SSW7-USB can be connected to the PC via the USB cable supplied. The SSW7-USB is powered from the PC. The SSW7-USB can therefore be used at any point in the MPI bus. A driver for creating a virtual COM-port is included.

Accessory-Note

By using SHTools software parameterization and diagnostic functions are possible. For firmware update a free download of the latest SHTools version is available on our website www.helmholz.com.

Features

- Programming and visualization via USB
- MPI up to 187.5 kbps
- Supply Voltage via USB
- Virtual COM-port for flexible applications

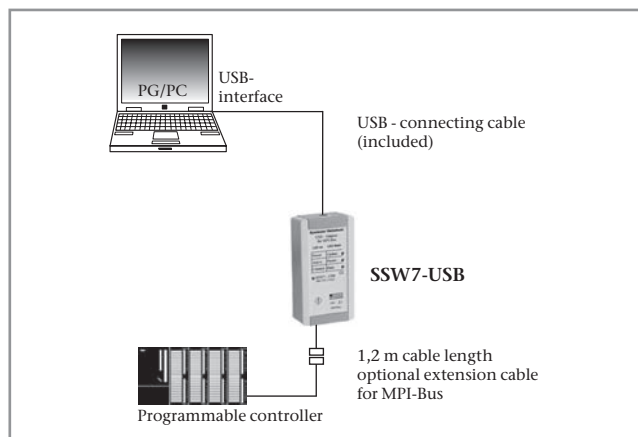

Application example for SSW7-USB

Technical Data	
Dimensions (D x W x H mm)	105 x 53 x 29
Weight	Approx. 180 g
Supply voltage	5 V via USB
Current consumption	Approx. 150 mA
MPI interface	
Type	RS485
Transmission rate	19.2 or 187.5 kbps
Cable connector	SUB-D, 9-way
Communication interface	
Type	USB 1.1
Protocols	PC <-> S7
Connection	USB-B female
Degree of protection	IP 20

Ordering Data	Order No.
MPI-Adapter SSW7-USB (incl. 3 m USB cable, manual, CD with software)	700-755-1VK21
DIN rail adapter short	700-751-HSH01

From STEP¹⁾ 7 version 5.5 SP2 Siemens no longer supports serial COM ports when using Windows 7²⁾ 64 bit. The TIA Portal¹⁾ also supports no COM ports - no matter what operating system is installed.

- 1) STEP and TIA Portal are registered trademarks of Siemens AG.
2) Windows 7 is a registered trademark of Microsoft Corporation.

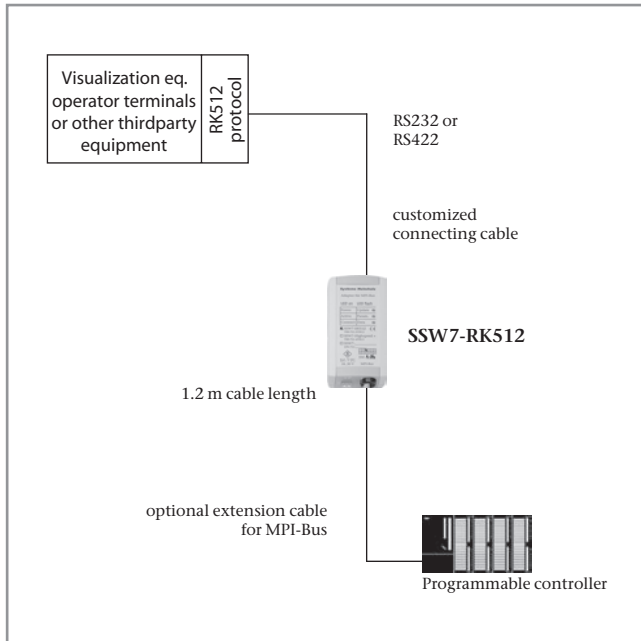

SSW7-RK512

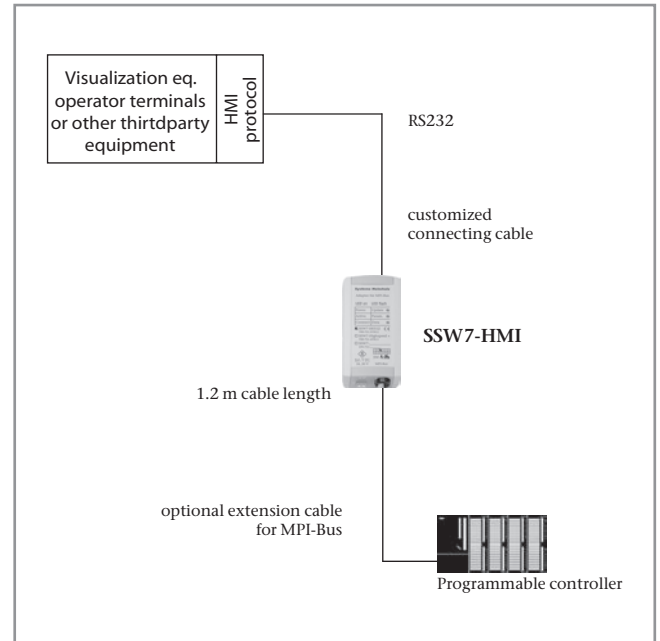

SSW7-HMI

SSW7-RK512

With the SSW7-RK512 you can connect any operator terminal, visualization equipment, or other third-party equipment to the S7 without adapting the software, if they support the RK512 protocol.

The SSW7-RK512 transmits data blocks, flags, inputs and outputs. The MPI settings of the SSW7-RK512 can be changed with a parameterization program or with special RK512 frames in order to connect several SSW7-RK512s or several PLCs to an MPI bus. The RS232 interface of the SSW7-RK512 has automatic baud rate detection for adapting itself to the connected device (between 9.6 and 115 kbps). The MPI interface operates with 187.5 kbps. The voltage supply for the SSW7-RK512 is taken from the CPU via the MPI bus. With an optional 24 V connection it can be operated anywhere else in the system.

We supply the SSW7-RK512 with an additional programming interface on the connector including switchable terminating resistor.

Accessory-Note

By using SHTools software parameterization and diagnostic functions are possible. For firmware update a free download of the latest SHTools version is available on our website www.helmholz.com.

SSW7-HMI

The SSW7-HMI is intended for use with operator terminals, visualization equipment or other third-party equipment that supports the Siemens HMI protocol.

The baud rate of the adapter is set by the protocol (between 9.6 and 115 kbps).

The voltage supply for the SSW7-HMI is taken from the CPU via the MPI bus. With an optional 24 V connection it can be operated anywhere else in the system.

We supply the SSW7-HMI with an additional programming interface on the connector including switchable terminating resistor.

Accessory-Note

By using SHTools software parameterization and diagnostic functions are possible. For firmware update a free download of the latest SHTools version is available on our website www.helmholz.com.

Ordering Data	Order No.
MPI-Adapter SSW7-RK512 (incl. manual)	700-751-5VK21
SSW7-RK512 with RS422 interface (incl. manual)	700-752-5VK21
DIN rail adapter short Power Plug (optional)	700-751-HSH01 700-751-SNT01

Ordering Data	Order No.
MPI-Adapter SSW7-HMI (incl. manual)	700-751-9VK21
DIN rail adapter short Power Plug (optional)	700-751-HSH01 700-751-SNT01

Technical Data			
	SSW7-RK512	SSW7-RK512 with RS422	SSW7-HMI
	700-751-5VK21	700-752-5VK21	700-751-9VK21
Dimensions (D x W x H mm)	105 x 53 x 29	105 x 53 x 29	105 x 53 x 29
Weight	Approx. 180 g	Approx. 180 g	Approx. 180 g
Supply voltage (from AG or current supply)	+24 V ±25 %	+24 V ±25 %	+24 V ±25 %
Current consumption	Approx. 70 mA	Approx. 70 mA	Approx. 70 mA
MPI-Schnittstelle Type	RS485	RS485	RS485
Transmission rate	187.5 kbps	187.5 kbps	19.2 or 187.5 kbps
Cable connector	SUB-D, 9-way with PG interface and witerminating resistor	SUB-D, 9-way with PG interface and witerminating resistor	SUB-D, 9-way with PG interface and witerminating resistor
Communication interface Type	RS232	RS422	RS232
Transmission type	Serial asynchronous	Serial asynchronous	Serial asynchronous
Transmission rate	19.2 ... 115.2 kbps	19.2 ... 115.2 kbps	4.800 ... 115.2 kbps
Parity	Even	Even	Odd
Data format	8 Bit	8 Bit	8 Bit
Protocols	RK512 with 3964/R	RK512 with 3964/R	HMI
Connection	Connector, SUB-D, 9-way	Connector, SUB-D, 9-way	Connector, SUB-D, 9-way
Degree of protection	IP 20	IP 20	IP 20



SSW5/LAN, S5 Ethernet Converter

The SSW5/LAN is an S5 Ethernet converter suitable for programming S5 controllers via the Ethernet. A special virtual COM-port driver enables the usage of common programming tools, e.g. STEP¹⁾ 5 V7.2 from Siemens. The power is drawn from the CPU or from an external source (24 V). A virtual COM port is available for all common installation tools.

Features

- S5 programming via TCP/IP
- Virtual COM port for all common installation tools
- Power supply from the CPU or external 24 V
- Compatible with every common S5 CPU
- Clearly recognition in the network by device name

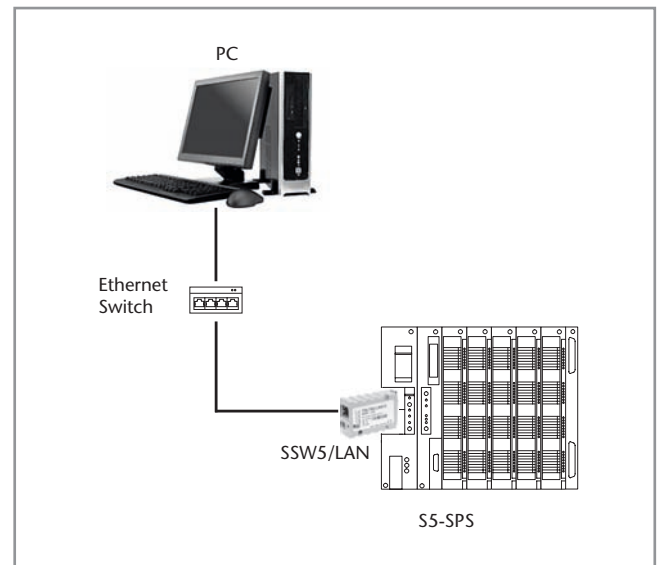

Application example SSW5/LAN

Ordering Data	Order No.
SSW5/LAN (incl. 3 m Ethernet cable, manual, CD with software)	700-750-LAN13

1) STEP is a registered trademark of Siemens AG.

Technical Data	
Dimensions (D x W x H mm)	65 x 21 x 42
Weight	Approx. 50 g
Power Supply Voltage	24 V DC via AG-interface or extern
Current consumption	Approx. 55 mA (typ.)
S5-AG Interface Type	TTY, 20 mA
Transmission rate	9.6 kBaud
Protocol	AS 511
Connection	15-way Sub-D connector
Ethernet interface Type	10 Base-T/100 Base-T; RJ45 female
Transmission rate	10/100 Mbps
Ambient temperature Transport and storage temperature	0 °C ... 60 °C -25 °C ... 75 °C
Degree of protection	IP 20

SSW5/USB, Programming Cable



SSW5/USB programming cable

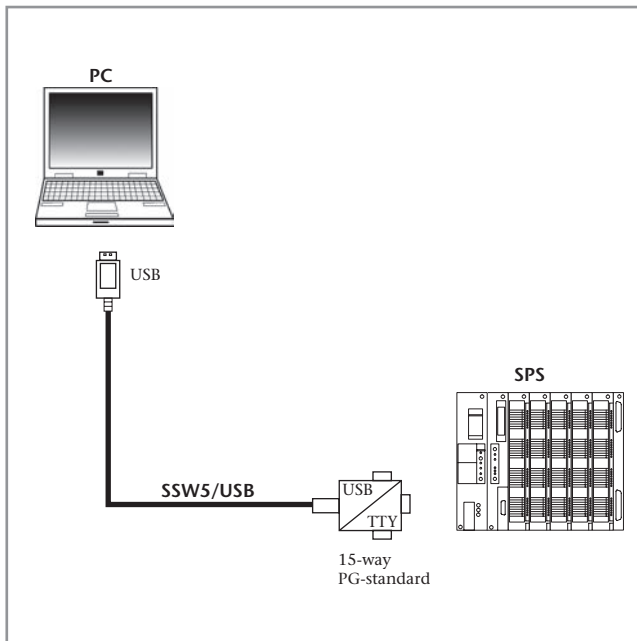

Application example SSW5/USB

The SSW5/USB programming cable enables a connection between a PC or Laptop via USB to an S5 PLC. A special virtual COM-port driver enables the usage of common programming tools, e.g. STEP¹⁾5 V7.2 from Siemens. The SSW5/USB is equipped with a 15-pole Sub-D connector.

Ordering Data	Order No.
SSW5/USB, programming cable, length 3 m (incl. manual, CD with software)	700-750-0US13
SSW5/USB, programming cable, length 5 m (incl. manual, CD with software)	700-750-1US13

1) STEP is a registered trademark of Siemens AG.

Technical Data	
Conversion Interface	USB to TTY USB
Transmission	USB
TTY interface	SUB-D male connector, 15-way
Max. transmission rate	38400 Bps
Max. cable length	5 m
Source of supply voltage	USB-sided

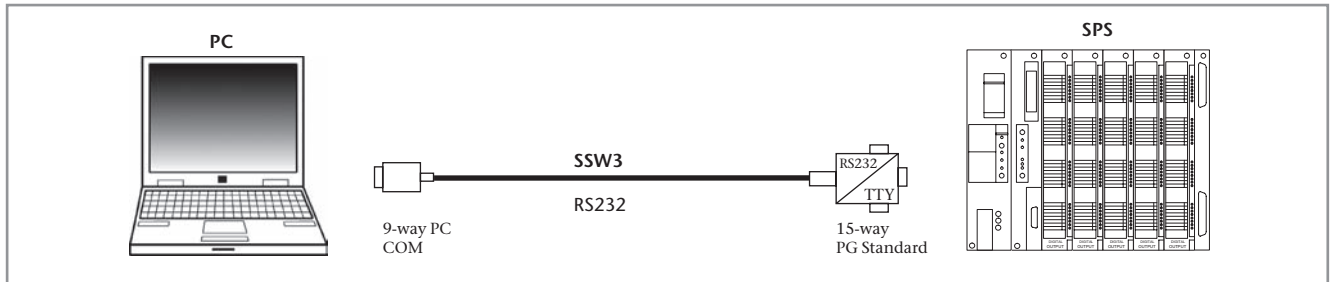

SSW3 interface converter cable

The SSW3 converter cable permits a connection between a PC and a PLC.
 The RS232/TTY converter is completely integrated in the 15-way connector housing. An external power supply is therefore not required.
 The data signals are transmitted via an **RS232** link.

Application in conjunction with:

- Any programming software on a PC
- Online link with the PLC with data exchange
- Visualization and communication software

Technical Data

Conversion	RS232 to TTY
Transmission	RS232
RS232 interface	SUB-D female connector, 9-way
TTY interface	SUB-D male connector, 15-way
Max. transmission rate	38400 Bps
Max. cable length	15 m
Source of supply voltage	PG

Ordering Data

Interface converter cable

SSW3, length 5 m

SSW3, length 10 m

SSW3, length 15 m

Order No.

700-750-0AA13

700-750-1AA13

700-750-2AA13



Service

Training Courses

Contact



The Systeme Helmholz GmbH also offers product training for:

- CAN Bus
- S7 Teleservice/Teleservice/Router
- NETLink® and OPC-server

The trainers will teach you all you need to know about correct handling of products by way of practical examples. Make an appointment with one of our specialists for your own in-depth consultation.

Please request your individual offer!

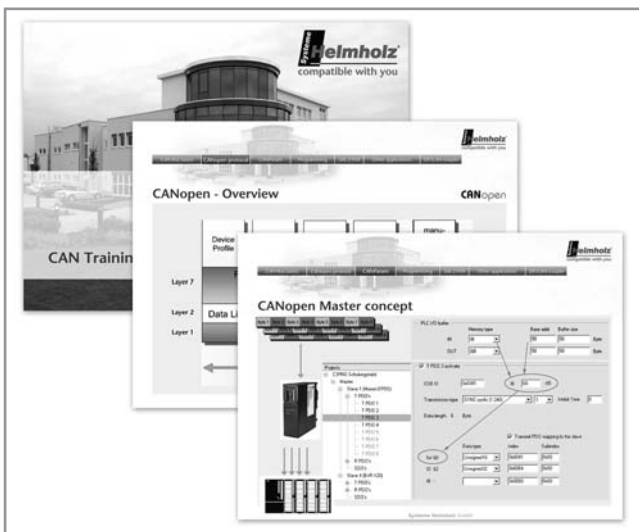

CAN Training Course

Contents:

- CAN concept
- CAN Layer 2 protocol
- CANopen® protocol
- CAN 300/CAN 400 parameterization & start-up
- CAN 300/CAN 400 programming in STEP¹⁾ 7
- DP/CAN Coupler

PROFIBUS Service

Your new service provider for field bus systems.

The transmission quality of field bus systems is a basic requirement for stably running machines and plants. Ever more complex applications and ever greater volumes of data can be transmitted quickly and reliably. We want to help you!

Systeme Helmholz GmbH offers not only a broad range of products for the PROFIBUS and CAN bus but also, with immediate effect, the following services connected with the field bus systems:

- Troubleshooting
- Diagnostics
- Planning support
- Seminars

The aim is to implement your individual requirements in cooperation with you.

Please request your individual offer!

Ordering Data

Training Course

CAN/CANopen®/CAN products, 1 day

Order No.

400-600-CAN01

1) STEP is a registered trademark of Siemens AG



REX Workshop

You want to ...
 ... remotely maintain independent from a modem?
 ... perform fast remote maintenance?
 ... remotely maintain Ethernet devices?
 ... achieve a high level of availability?

Then how about participating in one of our REX-Workshops!

Workshop contents

- Ethernet basics
- VPN basics
- Remote maintenance of MPI/PROFIBUS and Ethernet devices
- Remote maintenance over web portal (on-the-job)

At our REX 300 workshops you'll learn about prerequisites for internet remote maintenance, which problems need to be foreseen and how you can circumvent or solve them.

For maximum learning efficiency you will be required to put the trainings' concepts into practice yourself by establishing remote connections with test equipment.

Places/Dates

REX 300 workshops are held over the whole German-speaking area. The number of participants is limited to 18 people. You'll find a schedule with coming events on the support page of our website www.helmholz.de. For individual trainings at your facility please contact our team.

Your advantages

- Small groups with max. 3 participants per test equipment
- Up-to-date technical equipment
- Theory and practical experience in one workshop
- Free of cost
- Latest products

**Distribution North Germany****Holster Industrieelektronik GmbH**

Fasanenstieg 14
 22397 Hamburg
 Thomas D. Holster
 Phone: +49 (40) 605 18 18
 Fax: +49 (40) 605 55 93
 thomas.holster@helmholz.de

Distribution East Germany**B-S-K Industrievertretungen**

Holz-mühlen-strasse 4
 09212 Limbach-Oberfrohna
 Siegfried Renner
 Phone: +49 (376 09) 583 55
 Fax: +49 (376 09) 583 56
 siegfried.renner@helmholz.de

Distribution Baden-Württemberg**Systeme Helmholz GmbH**

Hannberger Weg 2
 91091 Großenseebach
 Timo Stegmüller
 Phone: +49 (91 35) 73 80-0
 Fax: +49 (91 35) 73 80-110
 timo.stegmueller@helmholz.de

Headquarters**Systeme Helmholz GmbH**

Hannberger Weg 2
 91091 Großenseebach
 Karsten Eichmüller
 Phone: +49 (91 35) 73 80-0
 Fax: +49 (91 35) 73 80-110
 karsten.eichmueller@helmholz.de

Distribution Bavaria**Systeme Helmholz GmbH**

Hannberger Weg 2
 91091 Großenseebach
 Martin Fröhlich
 Phone: +49 (91 35) 73 80-0
 Fax: +49 (91 35) 73 80-110
 martin.froehlich@helmholz.de

Distribution West Germany**Systeme Helmholz GmbH**

Hannberger Weg 2
 91091 Großenseebach
 Martin Güll
 Phone: +49 (91 35) 73 80-0
 Fax: +49 (91 35) 73 80-110
 martin.guell@helmholz.de

H-I Elektronik Vertrieb GmbH

Düsseldorfer Straße 547
 47055 Duisburg
 Thomas Dohmen
 Stephan Schmücker
 Phone: +49 (203) 76 14 03
 Fax: +49 (203) 76 44 00
 vertrieb@h-i-elektronik.de
 www.h-i-elektronik.de



Systeme Helmholz GmbH is present in the following countries:

Argentina	Malaysia
Australia	Mexico
Austria	Netherlands
Belgium	Norway
Brazil	Philippines
Bulgaria	Poland
Chile	Portugal
China	Romania
Croatia	Saudi Arabia
Czech Republic	Singapore
Denmark	Slovakia
Egypt	Slovenia
Estonia	South Africa
Finland	South Korea
France	Spain
Germany	Sweden
Hungary	Switzerland
India	Taiwan
Ireland	Thailand
Italy	Turkey
Japan	U.S.A.
Latvia	United Arabian Emirates
Lebanon	United Kingdom
Lithuania	Venezuela
Luxemburg	

Please find the contact details of your sales partner on our homepage www.helmholz.com.

Your Salespartner

Helmholz[®]
COMPATIBLE WITH YOU

Systeme Helmholz GmbH | Hannberger Weg 2 | 91091 Großenseebach
Phone +49 9135 7380-0 | Fax +49 9135 7380-110 | info@helmholz.de | www.helmholz.de