

VGrind 260

///// ROTARY TOOLS //

Grinding machine for complete machining
of rotary tools with maximum flexibility

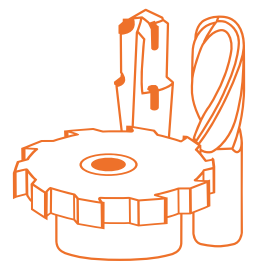

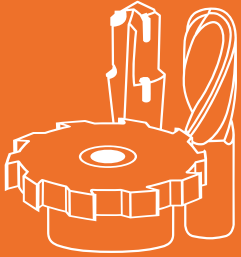

///// ROTARY TOOLS

DOUBLE SPINDLES FOR HIGH EFFICIENCY.

The **VGrind 260** has everything you could possibly need for completely machining your rotary tools. Ideal for sectors such as the automotive engineering, tool making, medical technology, precision engineering and aerospace industries, as well as many more.

The **VGrind 260** is equipped with tried-and-tested kinematics and a double spindle. Get ready for outstandingly precise multi-layer machining. And the best thing about it? You can configure the **VGrind 260** to meet your precise requirements.

From automating to coolant distribution to configuring the spindles and much, much more – assemble your machine so that it works exactly how you need it to. The **VGrind 260** offers a wealth of corresponding options.



VGrind 260

INDIVIDUALLY CONFIGURABLE.

1 // MODERN OPERATING CONCEPT

Height-adjustable, with touch screen, 19" diagonal screen size and optimum view into the machining chambers.

2 // WALL CONCEPT

Very rigid, compact construction with optimal accessibility and overview for the operator.

3 // MULTI-LAYER MACHINING

Two vertical grinding spindles with the grinding wheel at the C axis pivot point. Reduced machining times thanks to shorter linear-axis travel distances.

4 // INCLUDES IOT GATEWAY

The hot topic of Industry 4.0: Our machines are ready to communicate. An IoT gateway, which enables central machine data acquisition, is installed as standard.

5 // NUMROTOplus®

The reliable, intuitively operated software with 3D tool and machine simulation, combined with collision monitoring.

6 // GRINDING WHEEL CHANGER

Provides even more flexibility in your manufacturing processes – with up to eight grinding wheel packages.

7 // AUTOMATION

The VOLLMER HP 160 pallet magazine, the HC 4 chain magazine, or the internal pallet loader automatically ensures increased capacity and flexibility.

// THE MACHINE CONCEPT

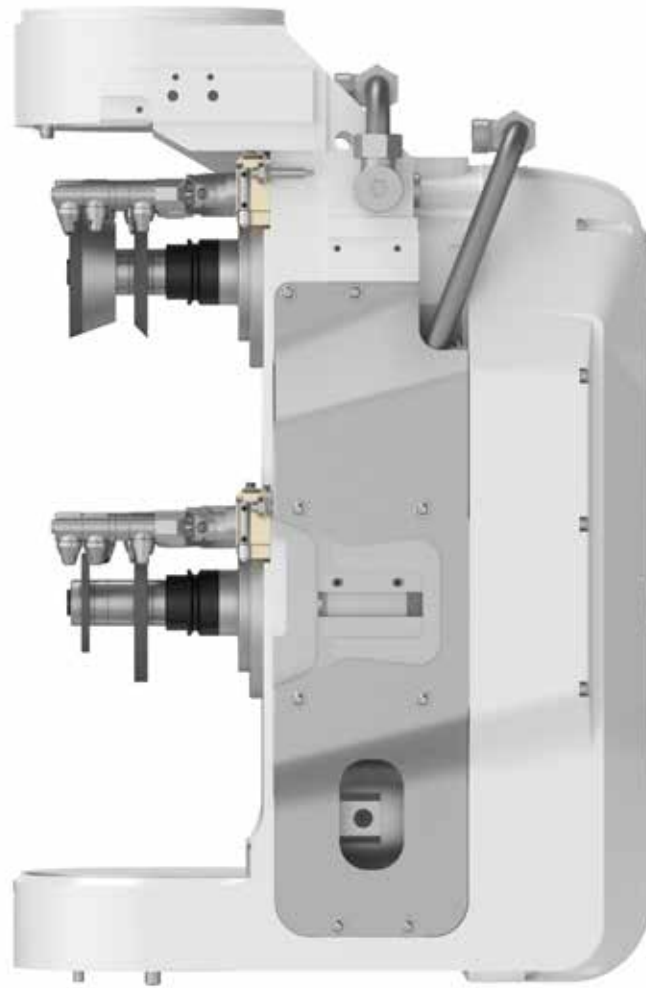

//////// GRINDING WHEEL PACKAGES
sit at the C axis pivot point

Precision and efficiency squared: This principle is also followed by the **VGrind 260** – thanks to two vertically configured grinding spindles. Its efficient cooling concept has been optimised. The result: Maximum perfection at the lowest tolerances with the best possible cooling.

/// Five-axis CNC grinding machine with innovative kinematics

/// Two grinding spindles situated one above the other with the grinding wheels positioned at the C axis pivot point – to ensure extremely precise grinding results

/// The two vertically positioned grinding spindles eliminate previous issues with the floating bearing compared to a single spindle with two ends

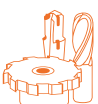



////// DOUBLE SPINDLE
for extremely precise grinding results

/// Innovative wall concept with the highest possible rigidity and outstanding damping thanks to polymer concrete

/// The plate heat exchanger on the **VGrind 260** guarantees effective, long-term cooling for the motors and grinding spindles.
Even better – no additional cooling unit is required

/// Both grinding spindles can be fitted with various different grinding wheel packages.
The automation option ensures seamless grinding wheel replacement, every time



// THE MACHINE CONCEPT

OPTIONAL EQUIPMENT

/// Flexible automation options for rotary tools

/// Grinding spindle available with direct or belt drive

/// Automatic changing of grinding wheel sets complete with coolant nozzles for optimum productivity

///// WHEEL MEASURING PROBE
Grinding wheel measurements
and wear control



///// GRIPPER COMPENSATION
Safe, precise loading and unloading

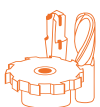

///// ROTARY TOOLS // MACHINE CONCEPT



///// ROUGHING UNIT
for opening the abrasive coating

/// The automatic handling mechanism compensation during the process ensures maximum precision when loading and unloading tools and reduction sleeves. This reduces wear and optimises concentricity

/// Wheel measuring probe: Grinding wheel measurements and wear control within the machine

/// Automated changing of intermediate sleeves with bayonet

/// Automatic roughing unit enables the grinding wheel coating to be opened during production

/// Simultaneous grinding wheel package and tool change in combination with the HP 160 pallet magazine or the HC 4 shortens non-productive times during loading

/// Stable, fully adjustable steady rest with automatic stroke ensures optimal grinding results



///// STEADY REST WITH AUTOMATIC STROKE
ensures an optimal grinding result
for longer tools

MAXIMUM PRECISION

///// For complete machining of tools.

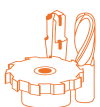



/// THE APPLICATION

The *VGrind 260* was designed for the efficient machining of rotary tools with different diameters.

The high flexibility provided by the possibility to change both grinding wheel packages, the reduced changing times and the range of automation options provide the best prerequisites for high-quality manufacturing.

For diameters up to 200 mm*

*For more information on the specifications, see page 15

// THE OPERATING CONCEPT

Thanks to its simple, intuitive operation, the **VGrind 260** ensures that you always have everything under control. The height-adjustable control desk, which features a clear LCD display, is positioned so that you always have a good view of the work area. During operation, you can choose to use the keyboard, touch screen or both – whichever is right for you.

The manual operating unit ensures even more flexibility: It can be freely positioned on the enclosure and is designed for setting individual axes – without using the control panel.

In short, the **VGrind 260** has been optimally designed with ergonomics and intuitive operation in mind – for your benefit. It makes it easy for you to achieve the best possible results.



///// ERGONOMIC OPERATION

Flexible, height-adjustable and tilting control desk, versatile manual operating unit, optimal view of the machine, simple access to the grinding spindles. It doesn't get more flexible than this.

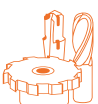



// NUMROTOPLUS® SOFTWARE

VOLLMER consciously opted for a well known system that is already established on the market. The logically structured interface guarantees intuitive handling. With established programming systems, a huge variety of tools can be manufactured and resharpened. You can change any detail of your tools and adapt them to your individual requirements.

Fully informed: Thanks to a perfect 3D simulation of the tool and machine. And with collision monitoring, you can always stay on the safe side.

- /// Develop
- /// Simulate
- /// Monitor
- /// Produce
- /// Measure
- /// Resharpen
- /// Document

////// RELIABLE SOFTWARE SYSTEM
NUMROTOplus®

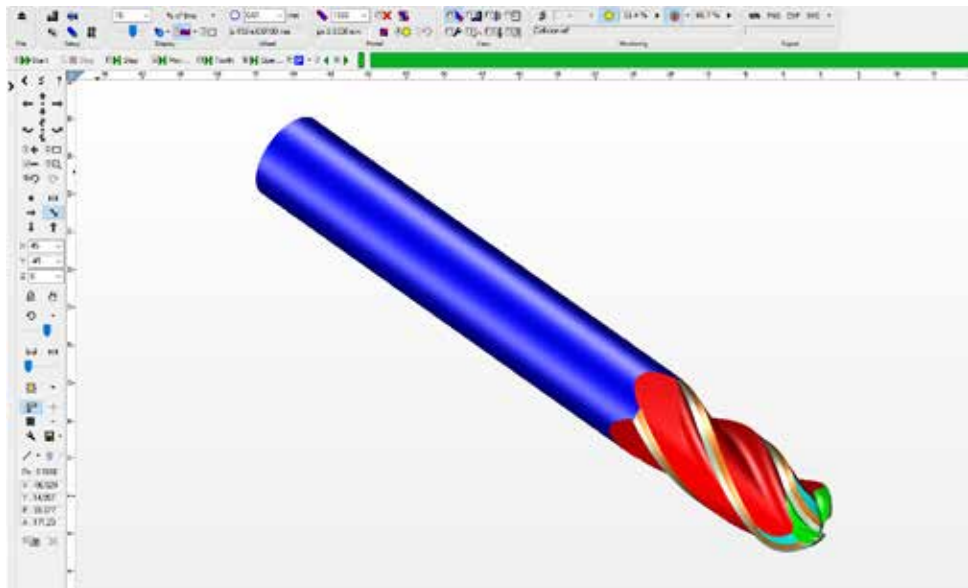

////// PROGRAMMING
of various tools

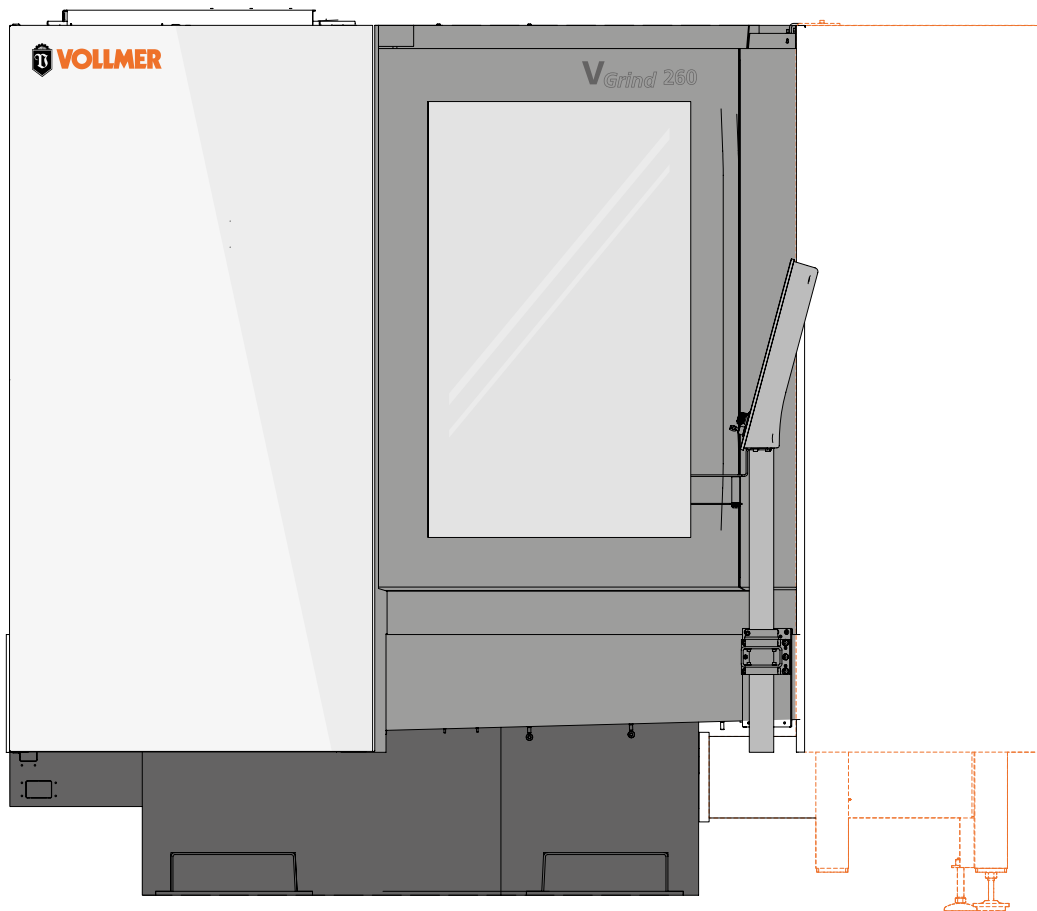

///// TOOL AUTOMATION
thanks to a range of automation options

// AUTOMATION

Work process automation is one of the key factors of modern tool machining. With the *VGrind 260*, you can choose from a range of excellent equipment options. This allows you to implement different batch sizes for your tools and to make your manufacturing processes quicker, safer and more precise.

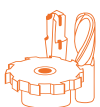

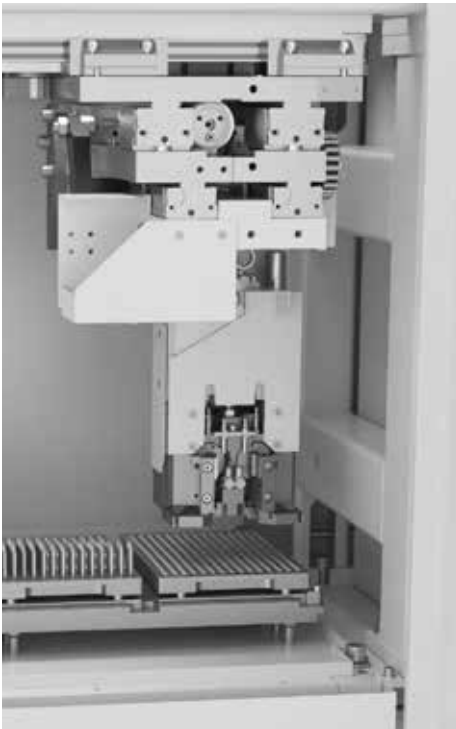

// TOOL AUTOMATION

The various automation options that we offer enable you to optimally adjust the *VGrind 260* to your requirements.

/// HP 160 pallet magazine with compact pallets (for up to 900 blanks or tools) and double gripper to guarantee quick changing times

/// The HC 4 chain magazine has space for 158 shank-type tools or, alternatively, up to 39 HSK-A63 tool holders in a compact design

/// Also available with an internal pallet loader. This provides space for two compact pallets with a capacity of up to 300 blanks or tools. Alternatively, chaotic loading of different shank diameters is also possible

///// HP 160 PALLET MAGAZINE
for quickly supplying up to
900 blanks or tools

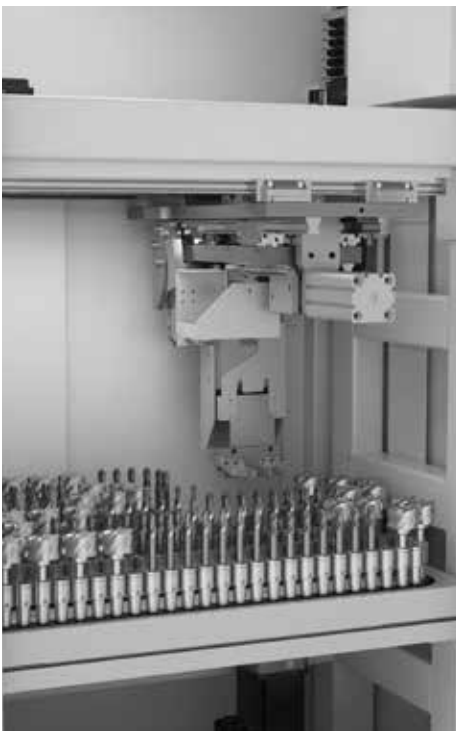

///// THE HC 4 CHAIN MAGAZINE
for 158 shank-type tools or up
to 39 HSK-A63 tool holders

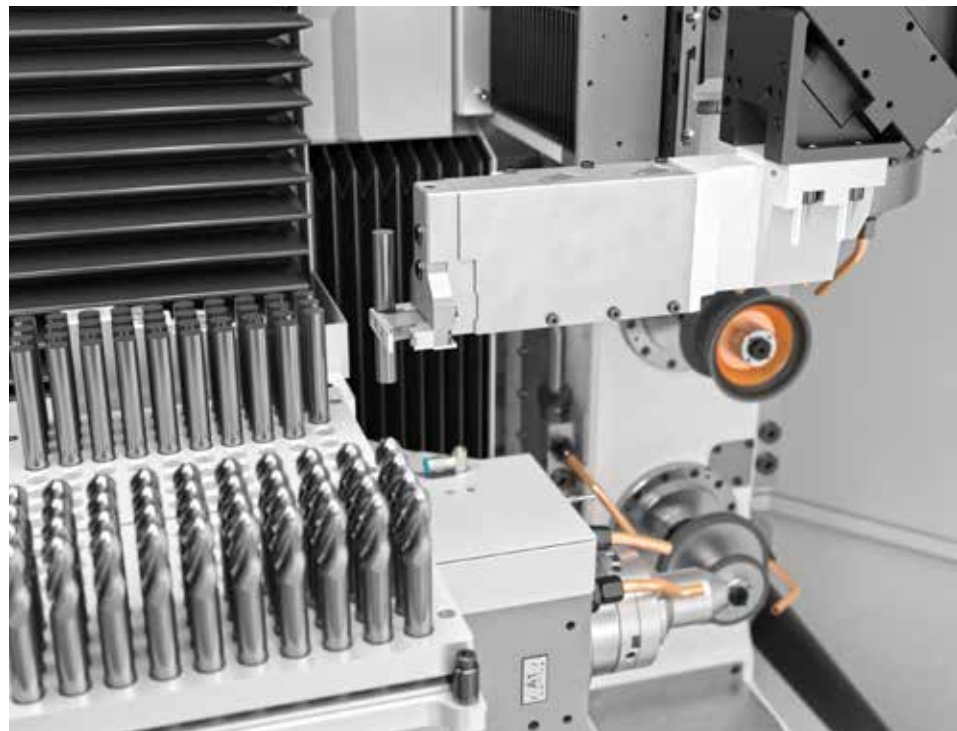

///// INTERNAL PALLET LOADER
with space for up to 300 blanks
or tools

// AUTOMATION

With the eight-tool grinding wheel changer, you automatically have the right grinding wheel on hand. If required, this can also include interchangeable coolant elements on both grinding spindles. This helps to increase productivity in your manufacturing facility.

The oriented spindle holder automatically positions the new grinding wheel packages in the same location on the grinding spindle. This reduces planing and run-out errors and therefore increases precision.



////// EIGHT-TOOL GRINDING WHEEL CHANGER
for efficient grinding wheel replacement and
reduction in non-productive time

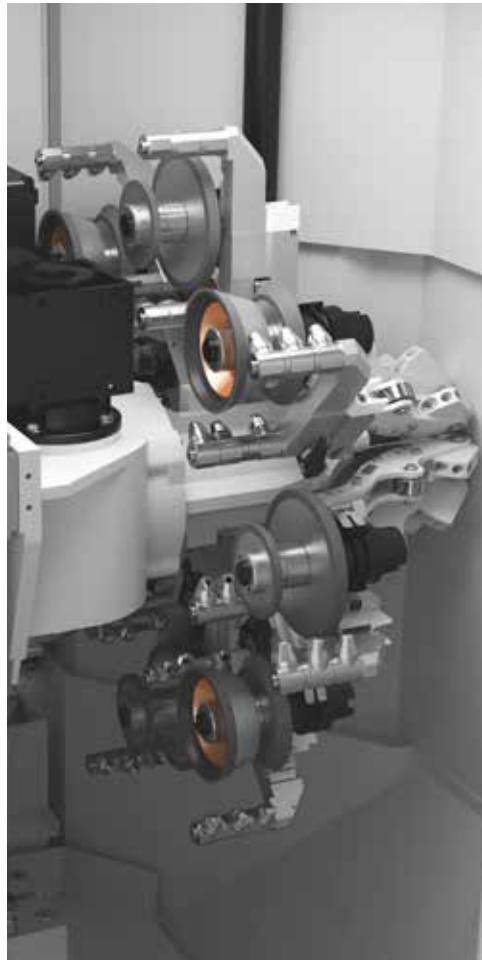

////// EIGHT-TOOL GRINDING WHEEL CHANGER
including interchangeable coolant elements

// SPECIFICATIONS

TOOL

Outside diameter of up to 200 mm*
Tool length of up to 360 mm**

GRINDING WHEEL

Max. diameter of 150 mm***

GRINDING SPINDLES

	Belt spindle	Belt spindle	Motor spindle
Speed	10,500 rpm	6500 rpm	16,000 rpm
Drive output 100% duty cycle	11 kW	5 kW	10 kW
Peak power	23 kW	9 kW	20 kW
Torque	14 Nm	7 Nm	9.5 Nm
Spindle adaption	HSK50***	HSK50***	HSK50***

TRAVERSE RANGES

X1 axis	425 mm
Y1 axis	490 mm
Z1 axis	500 mm
A1 axis	360°, 450 rpm
C1 axis	Optionally 1000 rpm +15° to -200°

CONNECTED LOAD Approx. 18 kVA

WEIGHT Approx. 4900 kg net

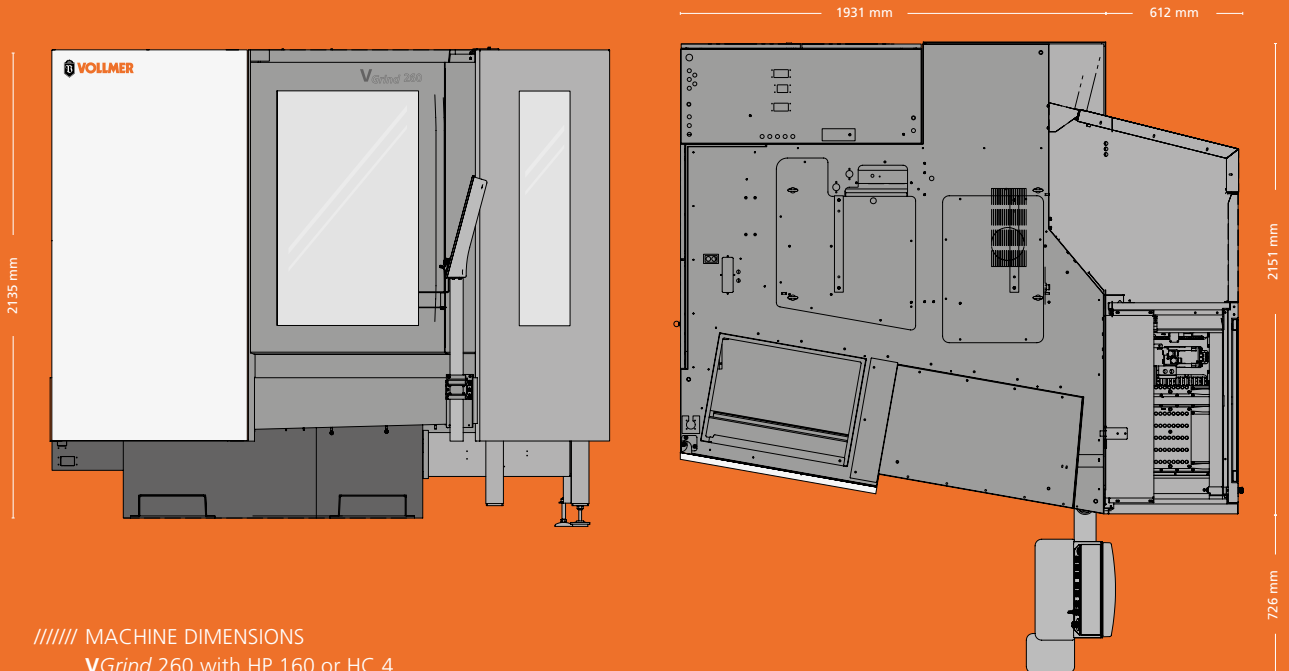

////// MACHINE DIMENSIONS
VGrind 260 with HP 160 or HC 4

We reserve the right to make design changes in the interest of technical progress. Patents pending.

* Depending on the equipping, the machine kinematics also allow for larger diameters.
** From the front edge of the workpiece carrier without measuring the cooling channel.
*** Max. 125 mm with supporting device.
**** Up to three grinding wheels per spindle end.



V@dison:

DIGITAL SOLUTIONS – PRECISION IN TRANSFORMATION

Do you want to optimise your processes with smart technologies, avoid mistakes and reduce downtimes? We offer grinding and sharpening machines that are equipped with an IoT gateway as standard. Contact your VOLLMER representative or find out more now at:

www.vollmer-group.com/en/products/digitalisation

**VGrind 260 – THE MAIN ADVANTAGES
AT A GLANCE:**

/// INCREASED PRECISION

Innovative kinematics with multi-layer machining for maximum quality of results. Benefit from uncompromising precision.

/// INCREASED EFFICIENCY

Shorter non-productive times thanks to intelligent and flexible automation. Experience productivity on a new level.

/// INCREASED USER CONVENIENCE

Good accessibility, ergonomically operated control panel and reliable software. Make your work easier.

/// INCREASED FLEXIBILITY

Efficiently machine tools with different diameters. For precision in the format of your choice.

315/en/800/04.22/Holzer