

Reisopack®

Strapping machine
Horizontal Automatic for pallets

2903

Strapping technologies



**The most rational
system for the
pallet strapping**

2903

Strapping machine Horizontal Automatic for pallets

**Useful system, simple and easy to program.
Suitable for use in fully automated lines.**

- Own manufacturing and technology using highest quality components.
- Compression system in the arch compacts load and guides the strap to the correct position.
- Mechanical tension adjustable through a holding strap system to get the highest tension.
- Aluminium head Reisopack 1900 long lasting.
- Approximate production higher than 60 pallet per hour.
- Security system under the arch with reverse engine.
- Visual signaling errors.

OPTIONS:

- Corner applicator (2904).
- Mobile base (2914).
- Corners Relocation Compactor (CRC).
- Four Faces Compactor (4FC).

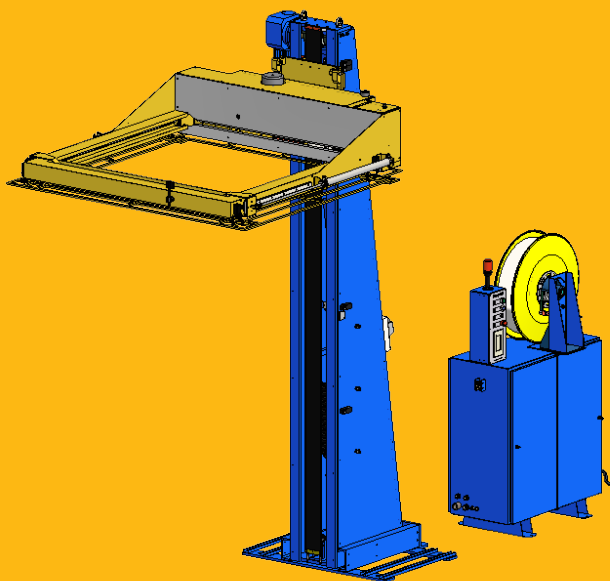

Strapping machine Horizontal Automatic for pallets

Control panel with touch screen.
Alarm display. Select the operating
language. Can store up to 10
programs. Each of them can have
a maximum of 10 strapping heights.

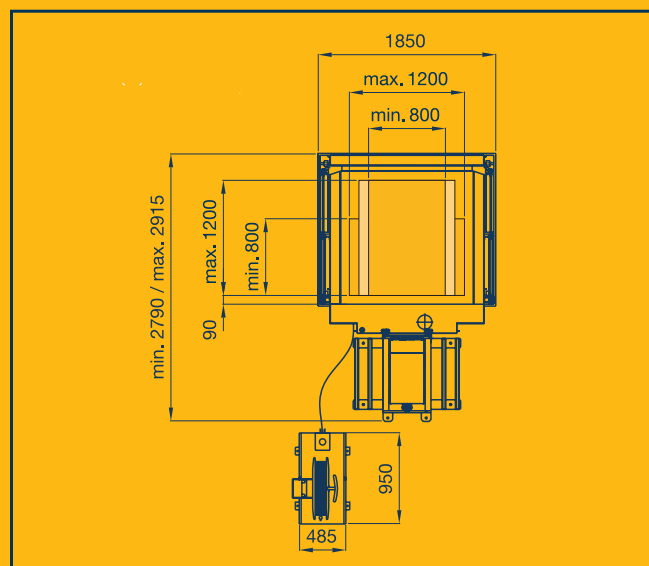
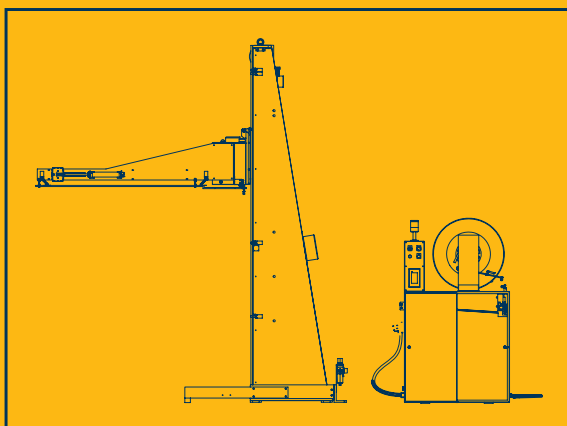

CHARACTERISTICS

- VOLTAGE:** 220 V / 240 V · 50 / 60 Hz. Triphasic
- ELECT. CONSUMPTION:** 2 Kw. **APROX. PRODUCT.:** 60-80 pallets / hour.
- COMPRESSED AIR PRESSURE:** 6 atm.
- PACKAGING DIMENSIONS:** 2 packages (1200 Kg.).
3820 X 2020 X 1660 mm. / 1200 X 670 X 1960 mm.

TECHNICAL SPECIFICATIONS

- STRAP WIDTH:** 8-12-15,5 mm. (Factory set).
- STRAP THICKNESS:** 0,50-0,85 mm.
- HEATING SYSTEM:** Electrical heating.
Heating temperature and cooling time adjustable.
- MINIMUM HEIGHT STRAPPING:** 130 mm.

12/14 Edition - We reserve the right to made any modification without prevention

Reisopack s.l.

2903

Polígono Industrial "Z"
C/ De la Prensa, 3
08150 Parets del Vallès (Spain)

Tel. 902 153 448 - Fax 935 624 186
http://www.reisopack.com
E-mail: reiso@reisopack.com

Customer service: ☎ (+34) 935 735 340