

# MECOS

*Utillaje para Plegadora*  
*[www.mecos.es](http://www.mecos.es)*

ED22



# EXPERIENCE & INNOVATION



TECNOSTAMP, fondata nel 1978 a Piacenza, è diventata nel corso degli anni, una delle più grandi ed affermate aziende italiane nella produzione, progettazione e vendita di utensili di piegatura; in continua espansione grazie ad una capillare rete di rivenditori dislocati in ogni parte del mondo. In questa direzione molti investimenti sono stati fatti: l'acquisto di nuove macchinari e l'esigenza di dotarsi di tecnologie avanzate con lo scopo di incrementare il livello qualitativo e la gamma degli utensili a catalogo.

La produzione comprende una vasta gamma di utensili standard – punzoni matrici ed accessori- adatti ai vari tipi di presse piegatrici; tutti i prodotti TECNOSTAMP sono realizzati con acciai di alta qualità temprati ad induzione nelle parti usurabili per una maggiore durata e sottoposti ad un accurato controllo qualità e assistenza post vendita.

Non solo prodotti standard ma soluzioni mirate per applicazioni specifiche nei vari settori della lavorazione della lamiera. La chiave del grande successo di TECNOSTAMP è proprio il servizio dedicato ai clienti: il cliente prima di tutto!

L'azienda crede fortemente nella forza della sua produzione e nella competenza dei suoi collaboratori che quotidianamente mettono a disposizione le proprie capacità professionali e la propria esperienza per una continua crescita trovando soluzioni mirate e personalizzate in grado di soddisfare le esigenze dei clienti in modo veloce ed efficiente.

Ricerca, innovazione, qualità e passione sono i punti forza che hanno costruito negli anni il successo del marchio TECNOSTAMP e accompagnano la sua espansione nel mercato globale.



TECNOSTAMP, founded in 1978 in Piacenza, has become over the years, one of the biggest and most important Italian companies in the production, design and sale of bending tools; it's a world-wide-expanding company with a large network of dealers across the globe.

For this purpose many investments have been made: the purchase of new machines and the need to equip with advanced technologies in order to increase quality and expanding range of tools in the catalogue.

The production includes a wide range of standard tools- punches, dies and accessories – suitable for all types of Press Brakes; all TECNOSTAMP products are made of high quality hardened steels for induction on wear parts for longer life and subjected to accurate quality control and after sales service.

Not only standard products but targeted solutions for specific applications in the various sheet metal processing sectors.

The key to great success of TECNOSTAMP is the service dedicated to customers: the customer first of all!

The company strongly believes in the strength of its production and the expertise of its employees who daily make available their professional skills and experience for continuous growth by finding targeted and customized solutions that can meet customer needs quickly and efficiently.

Research, innovation, quality and passion are the strengths that have built over the years the success of TECNOSTAMP brand and drive its expansion into the global market.



## OUR PRODUCT LINES



# INDICE / INDEX

<b>RED</b>		AMADA - PROMECAM STYLE	11
<b>BLUE</b>		TRUMPF STYLE	45
<b>PLATINUM</b>		WILA STYLE	59
<b>ORANGE</b>		BYSTRONIC - BEYELER STYLE	71
<b>BLACK</b>		LVD STYLE	87
<b>RAINBOW</b>		AJIAL - AMERICAN - COLGAR - COLLY - HÄMMERLE - EHT - NEWTON - WEINBRENNER STYLES	97
<b>SKY</b>		LAME - SUPPORTO PER LAME - INSERTI A (Z) - SUPPORTI PER INSERTI A (Z) - INSERTI RAGGIATI - SUPPORTI PER INSERTI RAGGIATI BLADES - BLADES HOLDER - Z TOOL INSERTS - RADIUS INSERTS - RADIUS INSERT HOLDERS	109
<b>CORAL</b>		UTENSILI PER NON MARCARE NO MARKING TOOLS	121
<b>MAGENTA</b>		ADATTATORI PER TUTTE LE PRESSE ADAPTERS FOR ALL PRESS BRAKES	135
<b>YELLOW</b>		LAME CESCOIA SHEAR BLADES	153
<b>GREEN</b>		ACCESSORI PER TUTTE LE PRESSE ACCESSORIES FOR ALL PRESS BRAKES	155
<b>SILVER</b>		LAVORAZIONI MODIFICHE E RICONDIZIONAMENTO WORKING MODIFICATION REFURBISHED TOOLING	159
<b>GOLD</b>		UTENSILI SPECIALI PER TUTTE LE PRESSE SPECIAL TOOLING FOR ALL PRESS BRAKES	163

# INDICE / INDEX

CODE	$\alpha$	PAGE	CODE	$\alpha$	PAGE	CODE	$\alpha$	PAGE	CODE	$\alpha$	PAGE	CODE	$\alpha$	PAGE
10.115		116	10.517	60°	17	11.670	85°	15	12.050	60°	24	15.036		119
10.116		116	10.520	60°	17	11.680	85°	15	12.051		24	15.037		119
10.136	60°	18	10.672	85°	14	11.710	60°	18	14.010	60°	73	15.038		119
10.142	60°	17	11.103	35°	18	11.720	60°	18	14.020	80°	73	15.039		119
10.143	60°	17	11.104	35°	18	11.730	60°	18	14.030	28°	73	15.040		119
10.170	85°	14	11.151	85°	15	11.750	60°	17	14.040	86°	73	15.050		112
10.181		114	11.158	30°	19	11.780	30°	19	14.050	28°	73	15.310	60°	47
10.182		114	11.200	85°	14	11.800	85°	16	14.060	80°	73	15.320	28°	49
10.183		114	11.201	85°	14	11.810	30°	19	14.080		112	15.330	86°	47
10.184		114	11.230	85°	14	11.820	85°	15	14.085		112	15.335	86°	47
10.185		114	11.231	85°	14	11.831	85°	17	14.090		112	15.370	86°	47
10.186		114	11.232	85°	14	11.835	85°	15	14.095		112	15.380	86°	47
10.187		114	11.258	30°	19	11.840	85°	16	14.150	85°	75	15.450	28°	49
10.188		114	11.270	85°	14	11.848	85°	15	14.151	85°	75	15.480	80°	47
10.190		116	11.275	75°	14	11.849	85°	15	14.152	85°	75	15.620	28°	49
10.191		116	11.280	30°	18	11.850	85°	16	14.153	30°	75	15.700	86°	48
10.192		118	11.300		115	11.853	85°	14	14.154	30°	75	15.710	86°	48
10.193		118	11.301		115	11.855	85°	14	14.155	30°	75	15.720	28°	50
10.300		115	11.302		115	11.857	85°	14	14.156	85°	75	15.730	60°	49
10.301		115	11.303		115	11.863	85°	15	14.157	60°	75	15.750	28°	50
10.302		115	11.304		115	11.864	85°	15	14.158	85°	76	15.755		110
10.303		115	11.305		115	11.865	85°	14	14.159	85°	76	15.760		110
10.304		115	11.306		115	11.866	85°	15	14.160	85°	76	15.761	28°	111
10.305		115	11.307		115	11.867	85°	15	14.161	30°	77	15.763	28°	111
10.306		115	11.308		115	11.868	85°	14	14.162	30°	77	15.765	28°	111
10.307		115	11.309		115	11.869	85°	15	14.163	30°	77	15.766	28°	111
10.308		115	11.310		115	11.880	30°	19	14.164	85°	77	15.767	28°	111
10.309		115	11.311		115	11.904	30°	20	14.165	60°	76	15.768	28°	111
10.310		115	11.312		115	11.911	30°	20	14.166	85°	76	15.769	28°	111
10.311		115	11.313		115	11.914	30°	20	14.167	30°	75	15.774	84°	111
10.312		115	11.314		115	11.916	30°	20	14.168	85°	76	15.776	86°	111
10.313		115	11.315		115	12.022	86°	23	14.169	30°	77	15.790	84°	48
10.314		115	11.316		115	12.023	86°	23	14.250		117	15.800	86°	48
10.315		115	11.317		115	12.024	86°	23	14.251		117	15.902	24°	57-69
10.316		115	11.318		115	12.027	86°	23	14.252		117	15.904	24°	57-69
10.317		115	11.319		115	12.028	86°	23	14.280		110	15.905	24°	57-69
10.318		115	11.320		115	12.029	86°	23	14.281		110	16.010		116
10.319		115	11.321		115	12.032	86°	23	14.282		110	16.050		112
10.320		115	11.322		115	12.033	86°	23	14.908	24°	85	16.060		112
10.321		115	11.323		115	12.035	86°	23	14.910	24°	85	16.070		110
10.322		115	11.324		115	12.037	86°	23	14.912	24°	85	16.200	78°	89
10.323		115	11.514	30°	18	12.039	60°	23	15.010		116	16.201	78°	89
10.324		115	11.528	30°	19	12.040	60°	23	15.014		116	16.202	26°	89
10.325		115	11.530	30°	19	12.041	60°	24	15.018		116	16.203	26°	90
10.400		110	11.540	26°	19	12.042	60°	24	15.020		118	16.204	26°	90
10.500	60°	17	11.545	26°	19	12.043	30°	24	15.025		118	16.205	78°	90
10.506	60°	17	11.550	24°	43	12.044	26°	24	15.030		119	16.206	78°	90
10.510	60°	17	11.554	24°	43	12.045	30°	24	15.031		119	16.207	26°	90
10.511	30°	19	11.560	24°	43	12.046	30°	24	15.032		119	16.208	26°	90
10.514	30°	18	11.600	35°	18	12.047	30°	24	15.033		119	16.209	26°	90
10.515	30°	18	11.650	85°	14	12.048	30°	24	15.034		119	16.808	20°	95
10.516	60°	17	11.660	85°	15	12.049	60°	24	15.035		119	16.810	20°	95

# INDICE / INDEX

CODE	α	PAGE	CODE	α	PAGE	CODE	α	PAGE	CODE	α	PAGE	CODE	α	PAGE
16.812	20°	95	20.300	60°	32	20.506	85°	32	22.001		130	24.412	85°	80
16.908	20°	96	20.301	60°	32	20.508	85°	32	22.002		130	24.413	85°	80
16.910	20°	96	20.303	30°	40	20.510	85°	32	22.003		130	24.414	85°	80
16.912	20°	96	20.305	26°	40	20.512	85°	32	22.004		130	24.415	85°	80
17.010		116	20.306		34	20.516	85°	32	22.005		130	24.453	30°	80
17.050		112	20.308	60°	32	20.520	85°	32	22.010		36	24.454	30°	80
17.070		110	20.311	60°	32	20.525	85°	32	22.020		36	24.455	30°	80
17.510		117	20.316		34	20.550		43	22.306	30°	37	24.456	30°	80
17.550		112	20.317	30°	32	20.554		43	22.308	30°	37	24.457	30°	80
17.570		110	20.318	30°	32	20.560		43	22.310	30°	37	24.458	30°	80
18.100		105	20.319	30°	32	20.610	60°	30	22.312	30°	37	24.459	30°	80
19.021	28°	61	20.320	30°	32	20.650	60°	29	22.316	30°	37	24.460	30°	80
19.022	80°	61	20.321	30°	32	20.680	60°	30	22.320	30°	37	24.462	30°	80
19.023	86°	61	20.322	30°	32	20.701		127	22.325	30°	37	24.465	30°	80
19.024	60°	61	20.323	30°	32	20.703		127	22.432	45°	37	24.503	85°	81
19.031	28°	62	20.336		34	20.705		127	22.440	45°	37	24.504	85°	81
19.032	80°	62	20.344	85°	35	20.707		127	22.606	60°	37	24.505	85°	81
19.033	86°	62	20.345	85°	35	20.709		127	22.608	60°	37	24.506	85°	81
19.034	60°	62	20.346	85°	35	20.720	80°	127	22.610	60°	37	24.507	85°	81
19.041		70	20.347	85°	35	20.725	80°	127	22.612	60°	37	24.508	85°	81
19.221	28°	61	20.348	85°	35	20.732	80°	127	22.616	60°	37	24.509	85°	81
19.224	86°	61	20.349	85°	35	20.820	85°	28	22.620	60°	37	24.510	85°	81
19.225	80°	61	20.350		28	20.830	30°	28	22.625	60°	37	24.511	85°	81
19.226	45°	61	20.351	30°	33	21.125	80°	31	22.832	84°	37	24.512	85°	81
19.231	28°	61	20.352	30°	33	21.160	80°	31	22.840	84°	37	24.513	85°	81
19.233	80°	62	20.353	30°	33	21.200	70°	31	22.904	86°	37	24.514	85°	81
19.235	80°	62	20.354	30°	33	21.207		28	22.906	86°	37	24.515	85°	81
20.200		34	20.370	60°	29	21.209		28	22.908	86°	37	24.540	60°	81
20.201		34	20.380	45°	30	21.231	26°	41	22.910	86°	37	24.550	60°	81
20.210	85°	29	20.386	60°	33	21.264	35°	41	22.912	86°	37	24.553	30°	81
20.211	85°	29	20.387	60°	33	21.280		129	22.914	86°	37	24.554	30°	81
20.212	85°	29	20.388	60°	33	21.289		129	22.916	86°	37	24.555	30°	81
20.213	85°	30	20.389	60°	33	21.290		129	22.918	86°	37	24.556	30°	81
20.214	85°	30	20.390	60°	33	21.291		129	22.920	86°	37	24.557	30°	81
20.215	85°	30	20.391	60°	33	21.292		129	22.925	86°	37	24.558	30°	81
20.216	80°	30	20.392	60°	33	21.303	30°	41	24.017	30°	80	24.559	30°	81
20.217	80°	30	20.400		34	21.305	26°	41	24.018	30°	80	24.560	30°	81
20.231	26°	40	20.401	30°	33	21.406	35°	33	24.040	60°	80	24.561	30°	81
20.240		29	20.402	30°	33	21.408	35°	33	24.050	60°	80	24.562	30°	81
20.264	35°	40	20.403	30°	33	21.410	35°	33	24.060	60°	80	24.563	30°	81
20.271		129	20.406	35°	32	21.412	35°	33	24.080	80°	80	24.564	30°	81
20.272		129	20.408	35°	32	21.416	35°	33	24.180	80°	80	24.565	30°	81
20.273		129	20.410	35°	32	21.420	35°	33	24.320	30°	80	24.570	60°	81
20.274		129	20.412	35°	32	21.425	35°	33	24.403	85°	80	24.580	80°	81
20.287		34	20.416	35°	32	21.450	30°	41	24.404	85°	80	24.600	80°	81
20.289		129	20.420	35°	32	21.506	85°	33	24.405	85°	80	25.100	86°	53
20.290		129	20.425	35°	32	21.508	85°	33	24.406	85°	80	25.101	86°	53
20.291		129	20.438	30°	35	21.510	85°	33	24.407	85°	80	25.102	86°	53
20.292		129	20.440	45°	29	21.512	85°	33	24.408	85°	80	25.103	86°	53
20.297	60°	32	20.450	30°	40	21.516	85°	33	24.409	85°	80	25.104	86°	53
20.298	60°	32	20.478	30°	35	21.520	85°	33	24.410	85°	80	25.105	86°	53
20.299	60°	32	20.484	45°	29	21.525	85°	33	24.411	85°	80	25.106	86°	53

# INDICE / INDEX

CODE	α	PAGE	CODE	α	PAGE	CODE	α	PAGE	CODE	α	PAGE	CODE	α	PAGE
25.107	86°	53	25.605	86°	54	26.253	30°	92	29.420	40°	123	32.812	88°	131
25.108	86°	53	25.606	86°	54	26.254	30°	92	29.430	60°	123	32.816	88°	131
25.109	86°	53	25.607	86°	54	26.255	30°	92	29.440	60°	123	33.306	30°	131
25.110	86°	53	25.621	84°	54	26.256	30°	92	29.450	60°	123	33.308	30°	131
25.111	80°	53	25.622	84°	54	26.257	30°	92	29.460	60°	123	33.310	30°	131
25.112	80°	53	25.623	84°	54	26.258	30°	92	29.510	86°	64	33.312	30°	131
25.113	80°	53	25.624	84°	54	26.259	30°	92	29.511	86°	64	33.316	30°	131
25.114	80°	53	25.625	84°	54	26.260	30°	92	29.512	86°	64	33.406	45°	131
25.115	80°	53	25.626	84°	54	26.262	78°	92	29.513	80°	64	33.408	45°	131
25.116	60°	53	25.627	80°	54	26.263	78°	92	29.514	80°	64	33.410	45°	131
25.200	84°	53	25.628	80°	54	26.264	78°	92	29.515	80°	64	33.412	45°	131
25.201	84°	53	25.629	80°	54	26.265	78°	92	29.517	80°	64	33.416	45°	131
25.202	84°	53	25.630	80°	54	26.266	78°	92	29.521	86°	64	33.420	45°	131
25.203	84°	53	25.901	30°	54	26.267	78°	92	29.522	86°	64	33.606	60°	131
25.204	84°	53	25.902	30°	54	26.268	78°	92	29.523	86°	64	33.608	60°	131
25.205	84°	53	25.903	30°	54	26.269	78°	92	29.524	86°	64	33.610	60°	131
25.206	84°	53	25.904	30°	54	26.270	78°	92	29.535	80°	64	33.612	60°	131
25.207	80°	53	25.905	30°	54	26.271	78°	92	29.551	30°	64	33.616	60°	131
25.208	80°	53	25.906	30°	54	26.272	78°	92	29.552	30°	64	33.620	60°	131
25.209	80°	53	25.907	30°	54	26.273	78°	92	29.553	30°	64	33.806	88°	131
25.210	80°	53	25.908	30°	54	26.274	78°	92	29.554	30°	64	33.808	88°	131
25.300	84°	53	25.909	30°	54	26.275	78°	92	29.561	30°	64	33.810	88°	131
25.301	84°	53	25.992		57-69-85	26.808		95	29.562	30°	64	33.812	88°	131
25.302	84°	53	25.994		57-69-85	26.810		95	29.563	30°	64	33.816	88°	131
25.303	84°	53	25.995		57-69-85	26.812		95	29.600	60°	124	33.820	88°	131
25.304	84°	53	26.005		130	26.908		96	29.850	70°	124	33.825	88°	131
25.350	86°	53	26.200	30°	92	26.910		96	31.306	30°	131	40.002		115
25.400	30°	53	26.201	30°	92	26.912		96	31.308	30°	131	40.003		114
25.401	30°	53	26.202	30°	92	28.100	80°	106	31.406	45°	131	40.010		156
25.402	30°	53	26.203	30°	92	28.820	60°-80°	28-106	31.408	45°	131	40.015		157
25.403	30°	53	26.204	30°	92	29.290	86°	65	31.410	45°	131	40.016		157
25.404	30°	53	26.205	30°	92	29.291	86°	65	31.606	60°	131	40.114	85°	26
25.405	30°	53	26.206	30°	92	29.292	86°	65	31.608	60°	131	40.116	85°	26
25.406	30°	53	26.207	30°	92	29.293	80°	65	31.610	60°	131	40.122	85°	26
25.407	30°	53	26.208	30°	92	29.297	80°	65	31.806	88°	131	40.419		112
25.408	30°	53	26.209	30°	92	29.321	86°	65	31.808	88°	131	40.500		113
25.409	30°	53	26.211	78°	92	29.322	86°	65	31.810	88°	131	40.510		113
25.410	30°	53	26.212	78°	92	29.323	86°	65	32.306	30°	131	40.511		113
25.421	30°	53	26.213	78°	92	29.324	80°	65	32.308	30°	131	40.515		113
25.422	30°	53	26.214	78°	92	29.325	80°	65	32.310	30°	131	40.516		113
25.423	30°	53	26.215	78°	92	29.326	80°	65	32.406	45°	131	40.520		113
25.424	30°	53	26.216	78°	92	29.330	30°	65	32.408	45°	131	40.521		113
25.425	30°	53	26.217	78°	92	29.336	86°	65	32.410	45°	131	40.525		113
25.500	30°	53	26.218	78°	92	29.351	30°	65	32.412	45°	131	40.526		113
25.501	30°	53	26.219	78°	92	29.352	30°	65	32.606	60°	131	40.530		113
25.502	30°	53	26.220	78°	92	29.353	30°	65	32.608	60°	131	40.535		113
25.503	30°	53	26.221	78°	92	29.354	30°	65	32.610	60°	131	40.540		113
25.504	30°	53	26.222	78°	92	29.361	30°	65	32.612	60°	131	40.545		113
25.601	86°	54	26.223	78°	92	29.362	30°	65	32.616	60°	131	40.550		113
25.602	86°	54	26.250	30°	92	29.363	30°	65	32.806	88°	131	40.555		113
25.603	86°	54	26.251	30°	92	29.384		70	32.808	88°	131	40.560		113
25.604	86°	54	26.252	30°	92				32.810	88°	131	40.565		113

# INDICE / INDEX

CODE	α	PAGE	CODE	α	PAGE	CODE	α	PAGE	CODE	α	PAGE	CODE	α	PAGE
40.570		113	50.529		144	50.940		138	60.955		147	70.949		12-168
40.575		113	50.551		144	50.945		143	60.960		146	71.100		144
40.580		113	50.571		144	50.950		99-140	60.965		147	701.050		12-169
40.585		113	50.574		145	50.959		138	60.980		99-147	800.000		136
40.590		113	50.577		145	50.960		139	62.094	180°	126	810.000		136
40.610		113	50.600		151	50.970		138	62.181		126	820.000		136
40.611		113	50.610		151	50.971		138	62.182		126			
40.612		113	50.615		151	50.972		143	62.183		126			
40.613		113	50.635		151	50.980		139	63.000		152			
40.614		113	50.640		151	50.981		139	63.121		152			
40.615		113	50.645		151	50.982		139	63.122		152			
40.629		126	50.646		151	50.983		139	63.123		152			
40.645		158	50.650		152	50.985		139	63.124		152			
40.650		158	50.651		152	50.990		140	63.126		152			
40.651		158	50.657		151	50.991		140	63.127		152			
40.652		158	50.666		137	50.992		140	63.128		152			
40.653		158	50.667		137	50.993		140	63.129		152			
40.660		156	50.668		137	50.994		140	70.010		160			
40.680	85°	26	50.669		137	50.996		140	70.015		160			
40.700		156	50.671		138	50.997		140	70.020		160			
40.740		156	50.673		137	50.998		140	70.025		160			
40.745		156	50.674		137	60.100		162	70.030		160			
40.750		156	50.680		137	60.102		126	70.035		160			
40.800		133	50.685		151	60.103		126	70.040		160			
40.810		132	50.693		145	60.105		126	70.050		162			
40.815		132	50.697		145	60.120		58	70.060		162			
40.820		132	50.705		137	60.130		58	70.070		162			
40.830		132	50.706		137	60.150		162	70.100		40			
40.835		132	50.707		137	60.200		162	70.102		40			
40.840		132	50.708		137	60.618		157	70.120		41			
40.845		132	50.710		137	60.619		157	70.121		41			
40.850		133	50.712		145	60.680		136	70.123		41			
40.860		133	50.720		41	60.681		136	70.130		46-60-89			
50.200		143	50.725		151	60.682		136	70.150		46-60-89-160			
50.210		143	50.730		151	60.683		136	70.500		12-160			
50.220		143	50.731		151	60.685		152	70.501		12-161			
50.250		143	50.800		150	60.691		152	70.502		12-162			
50.310		145	50.805		150	60.710		149	70.504		12-163			
50.400		139	50.810		150	60.715		149	70.600		12-164			
50.410		138	50.820		150	60.720		149	70.714		46-60-89			
50.415		138	50.825		150	60.725		149	70.715		46-60-89			
50.430		138	50.830		150	60.730		149	70.716		46-60-89			
50.440		138	50.835		150	60.735		149	70.717		46			
50.445		138	50.870		150	60.910		125-146	70.718		46-60-89			
50.450		138	50.875		150	60.919		146	70.719		46-60			
50.470		139	50.890		150	60.920		125-146	70.800		58			
50.490		139	50.900		144	60.925		146	70.810		58			
50.500		141	50.903		144	60.930		146	70.900		162			
50.501		141	50.905		144	60.935		125-146	70.946		12			
50.502		142	50.910		144	60.940		125-146	70.946		12-165			
50.503		142	50.930		105-141	60.945		147	70.947		12-166			
50.512		137	50.935		105-141	60.950		125-146	70.948		12-167			





# TABELLA DI PIEGATURA / BENDING CHART

FORZA NECESSARIA PER PIEGA A 90° IN ARIA DI LAMIERA CON RESISTENZA  
 FORCE REQUIRED FOR 90° AIR BENDING, SHEET RESISTANCE

R=45 Kg/mmq

T mm	6	8	10	12	16	20	25	32	40	50	63	80	100	125	160	200	250	V
	4	5.5	7	8.5	11	14	17.5	22	28	35	45	55	71	89	113	140	175	B
	1	1.3	1.6	2	2.6	3.3	4	5	6.5	8	10	13	16	20	26	33	41	Ri
0.5	3																	
0.6	4	4																
0.8	7	5	4															
1	11	8	7	6														
1.2	16	12	10	8	6													
1.5		17	15	13	9	8												
2			27	22	17	13	11											
2.5				35	26	21	17	13										
3					38	30	24	19	15									
4						54	42	34	27	21								
5							67	52	42	33	26							
6								75	60	48	38	30						
8									107	85	68	53	43					
10										134	105	85	67	53				
12											153	120	96	78	60			
15												188	150	120	95	75		
20													270	215	170	135	108	F t/m

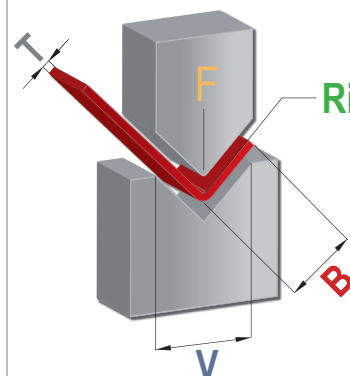

SPESSORE LAMIERA IN MM THICKNESS OF THE SHEET IN MM	T
FORZA IN TON / METRO FORCE IN TON / METER	F
RAGGIO INTERNO INSIDE RADIUS	Ri
BORDO MINIMO POSSIBILE MINIMUM FLANGE LENGHT	B
LARGHEZZA DEL V V-OPENING	V

ALLUMINIO ALUMINIUM	R=20-25 KG/MMQ
ACCIAIO DOLCE MILD STEEL	R=40-45 KG/MMQ
INOX STAINLESS STEEL	R=65-70 KG/MMQ

CALCOLO DELLA FORZA PER PIEGA IN ARIA  
 CALCULATION OF FORCE FOR AIR BENDING

$$F = \frac{T^2 \times 2 \times R}{1.4 \times V} = \dots\dots\dots \text{Tons/mt}$$

RAPPORTO TRA SPESSORE DI LAMIERA E AMPIEZZA DEL V SHEET THICKNESS / V - WIDTH	SPESSORE LAMIERA (mm) SHEET THICKNESS (mm)	0.5 - 2.5	3 - 8	9 - 10	12 OR MORE
	AMPIEZZA DEL V (mm) V - WIDTH (mm)	6 T	8 T	10 T	12 T

## LEGENDA DEI MATERIALI MATERIAL SPECIFICATIONS

	ACCIAIO C45 (UNI EN 10083 W.1. : 1.1191). STEEL C45 (UNI EN 10083 W.1. : 1.1191).
	ACCIAIO C45 (UNI EN 10083 W.1. : 1.1191) TEMPRATO AD INDUZIONE (52/55 HRC) SULLE PARTI USURABILI. STEEL C45 (UNI EN 10083 W.1. : 1.1191) INDUCTION TEMPERED (52-55 HRC) ON WEAR PARTS.
	ACCIAIO C45 (UNI EN 10083 W.1. : 1.1191) BONIFICATO R=80-85 KG/MMQ TEMPRATO AD INDUZIONE (52/55 HRC) SULLE PARTI USURABILI. STEEL C45 (UNI EN 10083 W.1. : 1.1191) HARDENED R=80-85 KG/MMQ INDUCTION TEMPERED (52-55 HRC) ON WEAR PARTS.
	ACCIAIO 42CRMO4 (UNI EN 10083 W.1. : 1.7225) BONIFICATO R=95-105 KG/MMQ TEMPRATO AD INDUZIONE (52/55 HRC) SULLE PARTI USURABILI. STEEL 42 CRMO4 (UNI EN 10083 W.1. : 1.7225) HARDENED R=95-105 KG/MMQ INDUCTION TEMPERED (52-55 HRC) ON WEAR PART.

TRATTAMENTI TERMICI HARDENED TREATMENT	GLI UTENSILI STANDARD E SPECIALI SONO TEMPRATI AD INDUZIONE SULLE PARTI USURABILI A 52-55 HRC. THE STANDARD AND SPECIAL TOOLS ARE INDUCTION HARDENED TO 52-55 HRC ON WEAR PARTS.
TRATTAMENTI ANTIUSURA ANTIWEAR TREATMENT	A RICHIESTA DEL CLIENTE, SUGLI UTENSILI COSTRUITI IN 42CRM04, PUÒ ESSERE FATTO UN TRATTAMENTO ANTIUSURA DI NITRURAZIONE. ON REQUEST ON THE TOOLING IN 42CRM04 TECNOSTAMP CAN MAKE AN ANTIWEAR-NITRIDING TREATMENT.
TRATTAMENTI ANTIRUGGINE RUSTING TREATMENT	A RICHIESTA DEL CLIENTE SUGLI UTENSILI PUÒ ESSERE FATTO IL TRATTAMENTO ANTI RUGGINE DI ZINCATURA. AN ANTI RUST-GALVANIZED TREATMENT CAN BE MADE ON TOOLS ON REQUEST.

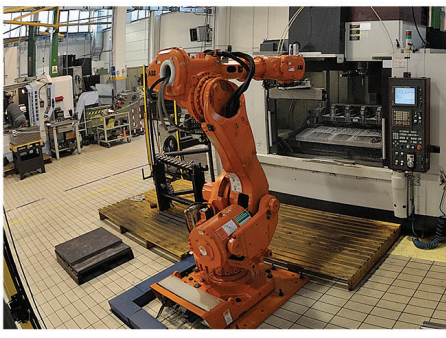

# AMADA - PROMECAM STYLE

PUNZONI

PUNCHES

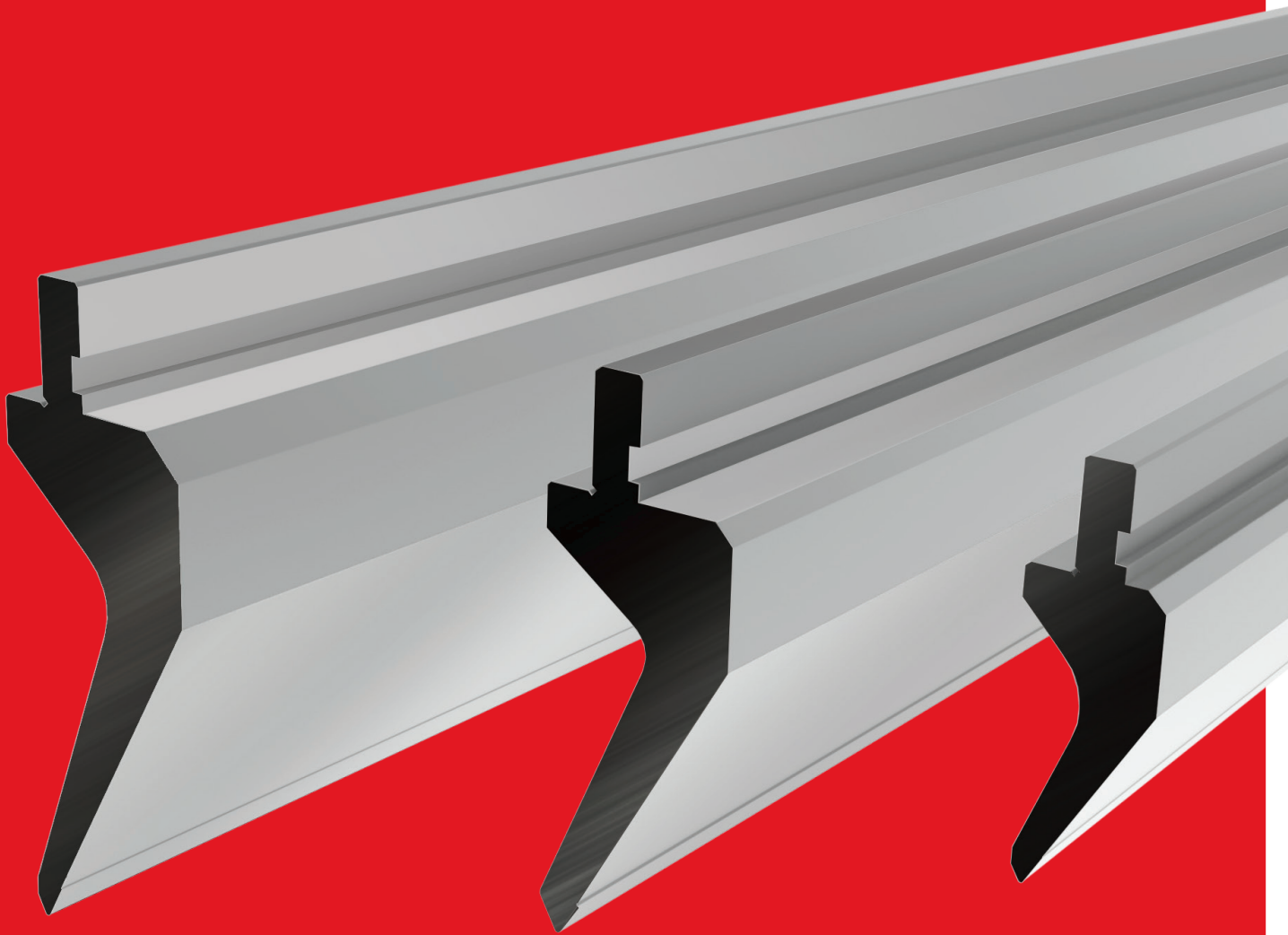

## RED LINE

AMADA - PROMECAM STYLE



# PUNZONI / PUNCHES *AMADA - PROMECAM STYLE*

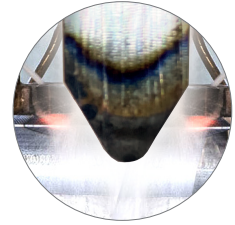
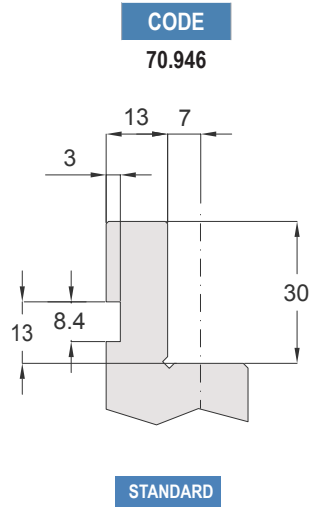
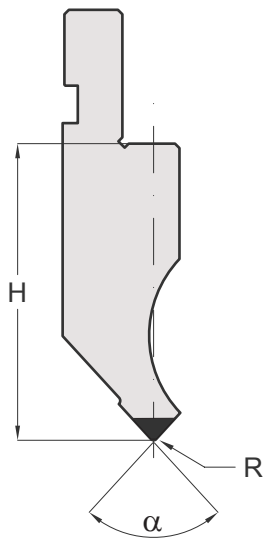

**TEMPRA AD INDUZIONE 52-55 HRC**  
**INDUCTION HARDENED 52-55 HRC**

<b>LEGENDA</b>	$\alpha$ = ANGOLO	R = RAGGIO	H = ALTEZZA
<b>LEGEND</b>	$\alpha$ = ANGLE	R = RADIUS	H = HEIGHT

SCANALATURA DI SICUREZZA SU RICHIESTA  
SAFETY GROOVE ON REQUEST

<p><b>CODE</b> 70.500</p> <p><b>EURO - BEYELER</b></p>	<p><b>CODE</b> 70.501</p> <p><b>EUROBEYELER - EURO WILA</b></p>	<p><b>CODE</b> 70.502</p> <p><b>DONEWELL - SAFAN - EUROBEYLER</b></p>	<p><b>CODE</b> 70.504</p> <p><b>AMADA ONE TOUCH</b></p>	<p><b>CODE</b> 70.600</p> <p><b>GASPARINI</b></p>
<p><b>CODE</b> 70.946</p> <p><b>AMADA / PROMECAM</b></p>	<p><b>CODE</b> 70.947</p> <p><b>COLGAR OLD STYLE</b></p>	<p><b>CODE</b> 70.948</p> <p><b>AMADA OLD STYLE</b></p>	<p><b>CODE</b> 70.949</p> <p><b>AMADA - BMB IDRAULIC</b></p>	<p><b>CODE</b> 70.1050</p> <p><b>AMADA - PROMECAM (CLARK)</b></p>

# PUNZONI / PUNCHES *AMADA - PROMECAM STYLE*

I PUNZONI STANDARD SONO DISPONIBILI A MAGAZZINO NELLE LUNGHEZZE DI: 415 / 835 E FRAZIONATI (800 mm)  
 THE PUNCHES ARE AVAILABLE IN THE FOLLOWING STANDARD LENGTHS: 415 / 835 AND SECTIONED (800 mm)

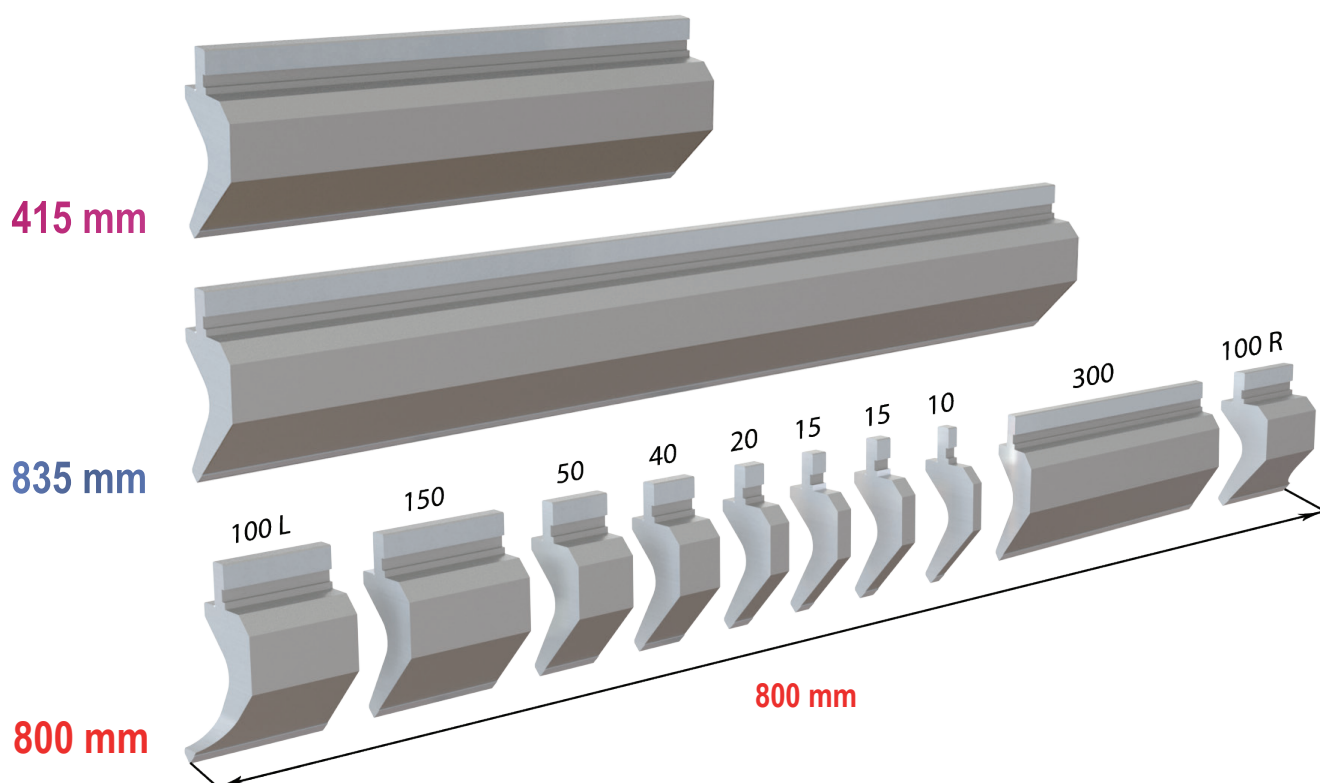

IL CARICO MASSIMO DELLE SCARPETTE CORRISPONDE AL 50% DEL CARICO MASSIMO INDICATO SUL PUNZONE.  
 THE MAX LOAD OF THE HORN EXTENSIONS IS 50% OF THE MAX LOAD OF THE PUNCH.

CODE					
10.142	10.520	11.231	11.670	11.853	11.866
10.500	11.151	11.275	11.835	11.855	11.867
10.506	11.200	11.280	11.840	11.863	
10.510	11.201	11.650	11.848	11.864	
10.517	11.230	11.660	11.850	11.865	

CODE					
10.511	11.158	11.540	11.730	11.820	11.916
10.514	11.258	11.545	11.750	11.880	
10.515	11.514	11.600	11.780	11.904	
11.103	11.528	11.710	11.810	11.911	

# PUNZONI / PUNCHES *AMADA - PROMECAM STYLE* 75° / 85°

CODE	$\alpha$	R	H	T/Mt	Mt
11.201	85°	3.00	65.45	100	■
11.200	85°	0.80	66.50	100	■
11.853	85°	0.25	66.50	100	■
11.275	75°	0.80	67.60	100	■

415 mm  
835 mm  
800 mm SECTIONED

CODE	$\alpha$	R	H	T/Mt	Mt
10.170	85°	0.60	66.74	35	■
11.857	85°	0.25	67.00	35	■

415 mm  
835 mm  
800 mm SECTIONED

CODE	$\alpha$	R	H	T/Mt	Mt
11.232	85°	0.80	135.00	100	■

415 mm  
835 mm  
800 mm SECTIONED

CODE	$\alpha$	R	H	T/Mt	Mt
11.231	85°	3.00	105.00	100	■
11.230	85°	0.80	105.00	100	■

415 mm  
835 mm  
800 mm SECTIONED

CODE	$\alpha$	R	H	T/Mt	Mt
11.855	85°	0.60	135.00	40	■

415 mm  
835 mm  
800 mm SECTIONED



CODE	$\alpha$	R	H	T/Mt	Mt
11.270	85°	0.60	95.00	50	■

415 mm  
835 mm  
800 mm SECTIONED

CODE	$\alpha$	R	H	T/Mt	Mt
11.650	85°	0.80	104.50	50	■
11.868	85°	0.25	104.70	50	■

415 mm  
835 mm  
800 mm SECTIONED

CODE	$\alpha$	R	H	T/Mt	Mt
11.865	85°	0.80	89.70	50	■
10.672	85°	0.25	90.00	50	■

415 mm  
835 mm  
800 mm SECTIONED

CODE	$\alpha$	R	H	T/Mt	Mt
11.866	85°	3.00	103.50	50	■
11.151	85°	0.80	104.50	50	■
11.867	85°	0.25	104.50	50	■

415 mm  
835 mm  
800 mm SECTIONED

CODE	$\alpha$	R	H	T/Mt	Mt
11.863	85°	3.00	88.50	60	■
11.660	85°	0.80	89.58	60	■
11.864	85°	0.25	89.70	60	■

415 mm  
835 mm  
800 mm SECTIONED

CODE	$\alpha$	R	H	T/Mt	Mt
11.670	85°	0.80	145.00	60	■

415 mm  
835 mm  
800 mm SECTIONED

CODE	$\alpha$	R	H	T/Mt	Mt
11.849	85°	0.80	165.00	60	■

415 mm  
835 mm  
800 mm SECTIONED

CODE	$\alpha$	R	H	T/Mt	Mt
11.848	85°	0.80	145.00	70	■

415 mm  
835 mm  
800 mm SECTIONED

CODE	$\alpha$	R	H	T/Mt	Mt
11.869	85°	0.80	105.00	45	■

415 mm  
835 mm  
800 mm SECTIONED

CODE	$\alpha$	R	H	T/Mt	Mt
11.835	85°	0.80	120.00	50	■

415 mm  
835 mm  
800 mm SECTIONED

CODE	$\alpha$	R	H	T/Mt	Mt
11.820	85°	0.60	115.00	20	■

415 mm  
835 mm  
800 mm SECTIONED

CODE	$\alpha$	R	H	T/Mt	Mt
11.680	85°	0.80	145.00	25	■

415 mm  
835 mm  
800 mm SECTIONED

# PUNZONI / PUNCHES *AMADA - PROMECAM STYLE* 85°

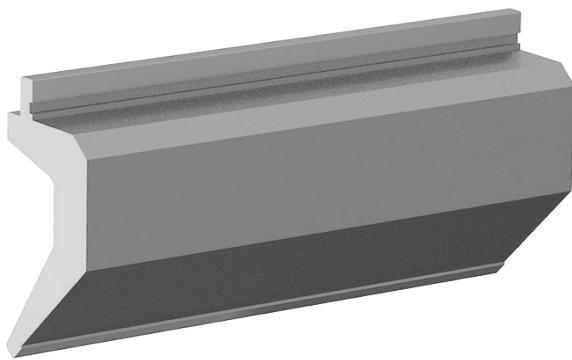
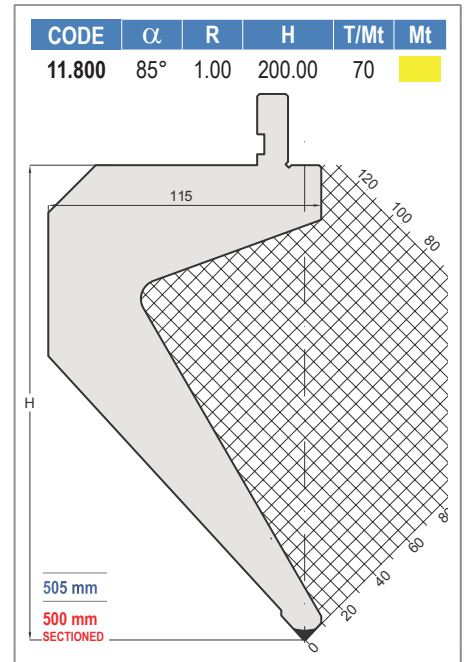
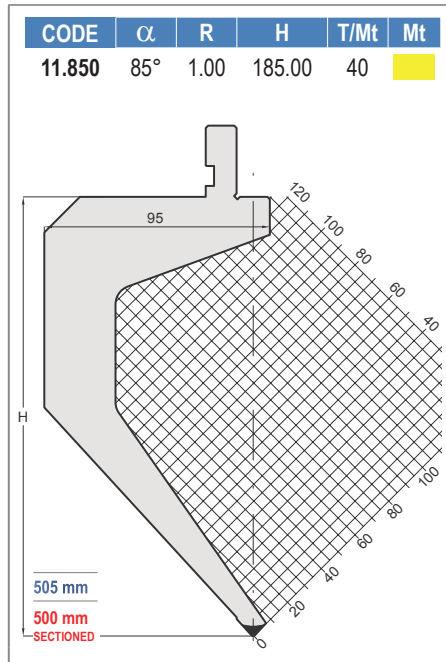
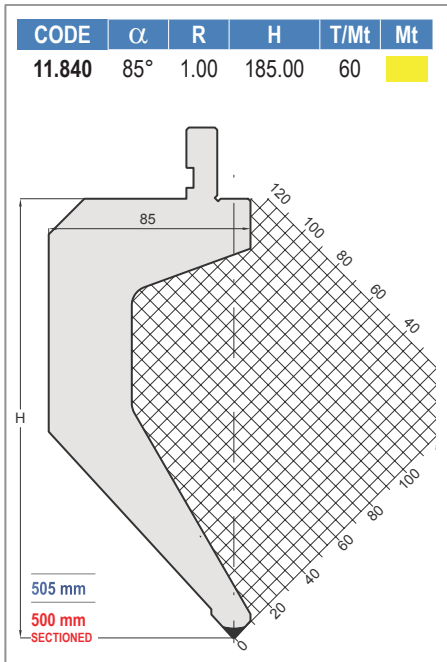

505 mm

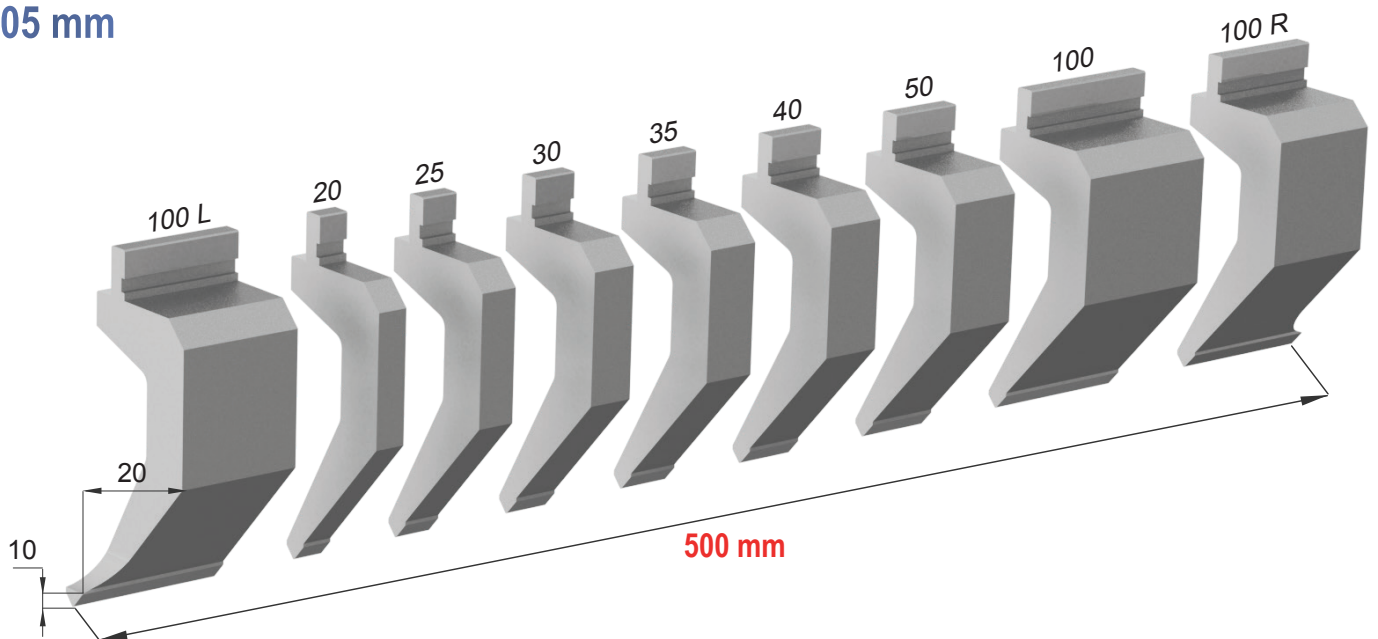

500 mm

IL CARICO MASSIMO DELLE SCARPETTE CORRISPONDE AL 50% DEL CARICO MASSIMO INDICATO SUL PUNZONE.  
 THE MAX LOAD OF THE HORN EXTENSIONS IS 50% OF THE MAX LOAD OF THE PUNCH.



# PUNZONI / PUNCHES *AMADA - PROMECAM STYLE* 60°/85°

CODE	$\alpha$	R	H	T/Mt	Mt
11.831	85°	0.60	85.00	12	<span style="background-color: yellow;">■</span>

415 mm  
835 mm  
800 mm SECTIONED

CODE	$\alpha$	R	H	T/Mt	Mt
10.516	60°	0.80	85.00	40	<span style="background-color: red;">■</span>

415 mm  
835 mm  
800 mm SECTIONED

CODE	$\alpha$	R	H	T/Mt	Mt
10.143	60°	2.00	65.80	60	<span style="background-color: green;">■</span>
10.142	60°	0.80	67.00	60	<span style="background-color: green;">■</span>

415 mm  
835 mm  
800 mm SECTIONED

CODE	$\alpha$	R	H	T/Mt	Mt
10.500	60°	0.80	115.00	40	<span style="background-color: red;">■</span>

415 mm  
835 mm  
800 mm SECTIONED

CODE	$\alpha$	R	H	T/Mt	Mt
10.506	60°	0.80	130.00	40	<span style="background-color: red;">■</span>

415 mm  
835 mm  
800 mm SECTIONED

CODE	$\alpha$	R	H	T/Mt	Mt
10.517	60°	0.80	80.00	25	<span style="background-color: yellow;">■</span>

415 mm  
835 mm  
800 mm SECTIONED

CODE	$\alpha$	R	H	T/Mt	Mt
10.510	60°	0.80	115.00	60	<span style="background-color: red;">■</span>

415 mm  
835 mm  
800 mm SECTIONED

CODE	$\alpha$	R	H	T/Mt	Mt
10.520	60°	0.80	115.00	50	<span style="background-color: red;">■</span>

415 mm  
835 mm  
800 mm SECTIONED

CODE	$\alpha$	R	H	T/Mt	Mt
11.750	60°	0.80	135.00	70	<span style="background-color: green;">■</span>

415 mm  
835 mm  
800 mm SECTIONED

# PUNZONI / PUNCHES *AMADA - PROMECAM STYLE* 30° / 35° / 60°

CODE	$\alpha$	R	H	T/Mt	Mt
10.136	60°	6.00	65.00	100	■

415 mm  
835 mm  
800 mm SECTIONED

CODE	$\alpha$	R	H	T/Mt	Mt
11.710	60°	5.00	115.00	100	■

415 mm  
835 mm  
800 mm SECTIONED

CODE	$\alpha$	R	H	T/Mt	Mt
11.720	60°	10.00	115.00	100	■

415 mm  
835 mm  
800 mm SECTIONED

CODE	$\alpha$	R	H	T/Mt	Mt
11.730	60°	5.00	145.00	160	■

415 mm  
835 mm  
800 mm SECTIONED

CODE	$\alpha$	R	H	T/Mt	Mt
10.515	30°	0.60	140.00	50	■

415 mm  
835 mm  
800 mm SECTIONED

CODE	$\alpha$	R	H	T/Mt	Mt
11.280	30°	0.60	95.00	50	■

415 mm  
835 mm  
800 mm SECTIONED

CODE	$\alpha$	R	H	T/Mt	Mt
11.104	35°	1.50	86.00	70	■
11.600	35°	0.80	90.00	70	■
11.103	35°	0.60	86.00	70	■

415 mm  
835 mm  
800 mm SECTIONED

CODE	$\alpha$	R	H	T/Mt	Mt
10.514	30°	0.60	80.00	50	■

415 mm  
835 mm  
800 mm SECTIONED

CODE	$\alpha$	R	H	T/Mt	Mt
11.514	30°	0.60	104.00	50	■

415 mm  
835 mm  
800 mm SECTIONED

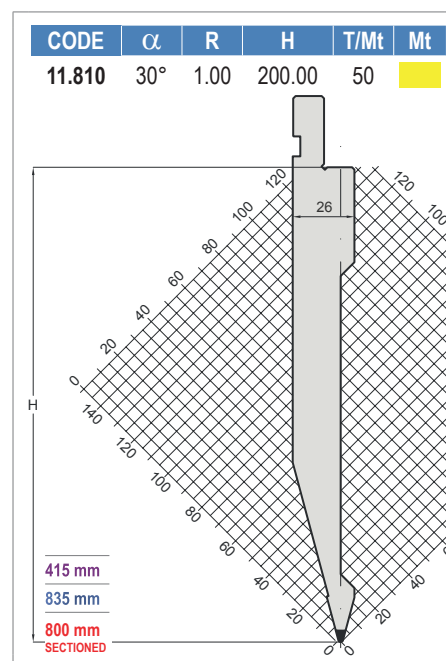
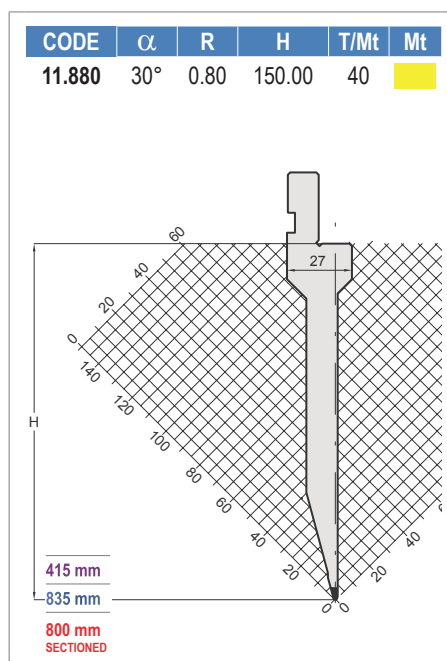
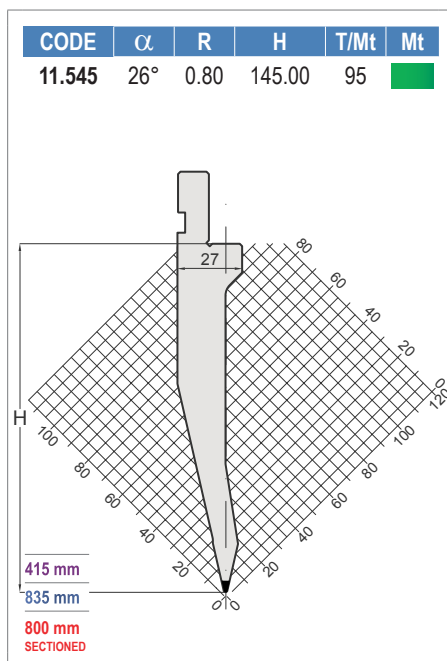
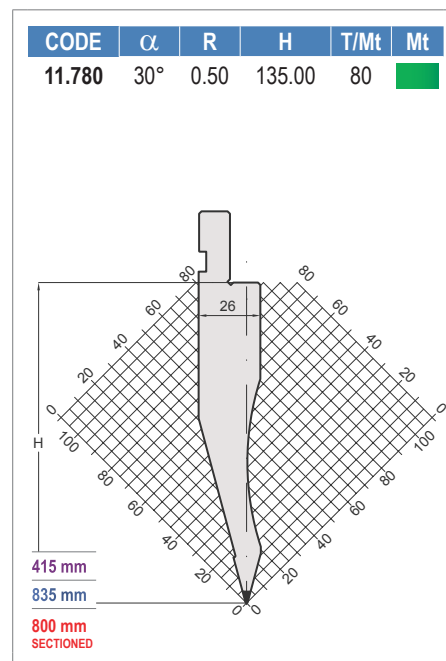
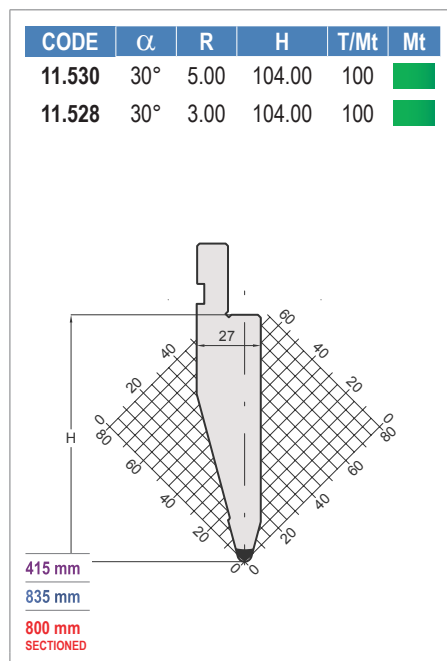
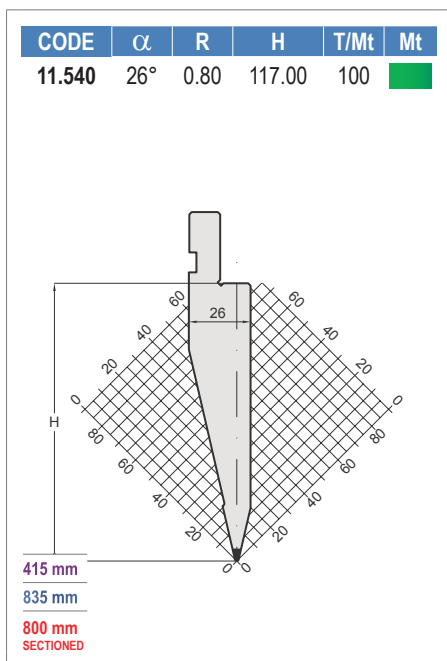
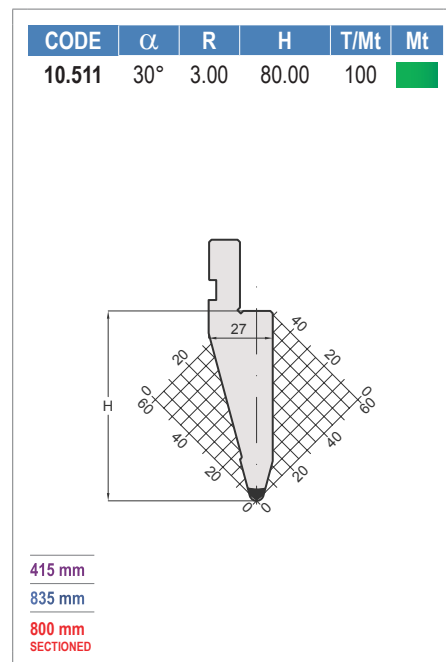
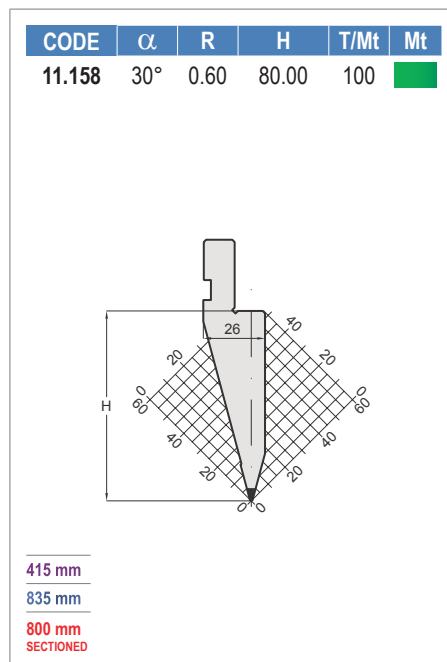
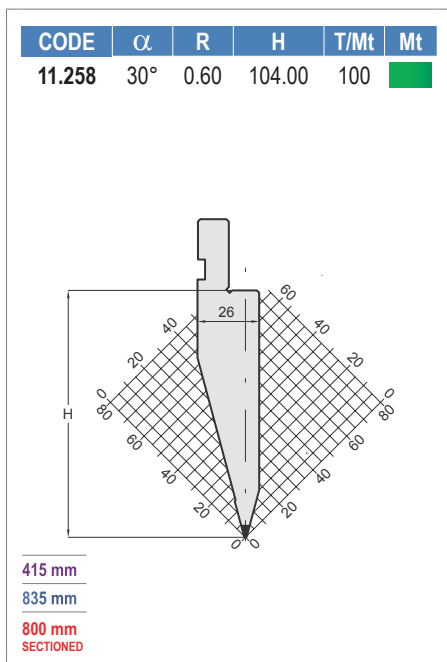

# PUNZONI / PUNCHES *AMADA - PROMECAM STYLE* 30°

CODE	$\alpha$	R	H	T/Mt	Mt
11.904	30°	10.00	83.00	100	<span style="background-color: green; color: white;"> </span>

415 mm  
835 mm  
800 mm SECTIONED

CODE	$\alpha$	R	H	T/Mt	Mt
11.911	30°	15.00	87.00	100	<span style="background-color: green; color: white;"> </span>

415 mm  
835 mm  
800 mm SECTIONED

CODE	$\alpha$	R	H	T/Mt	Mt
11.914	30°	17.50	89.00	100	<span style="background-color: green; color: white;"> </span>

415 mm  
835 mm  
800 mm SECTIONED

CODE	$\alpha$	R	H	T/Mt	Mt
11.916	30°	20.00	91.00	100	<span style="background-color: green; color: white;"> </span>

415 mm  
835 mm  
800 mm SECTIONED

# AMADA - AFH STYLE

## PUNZONI

## PUNCHES

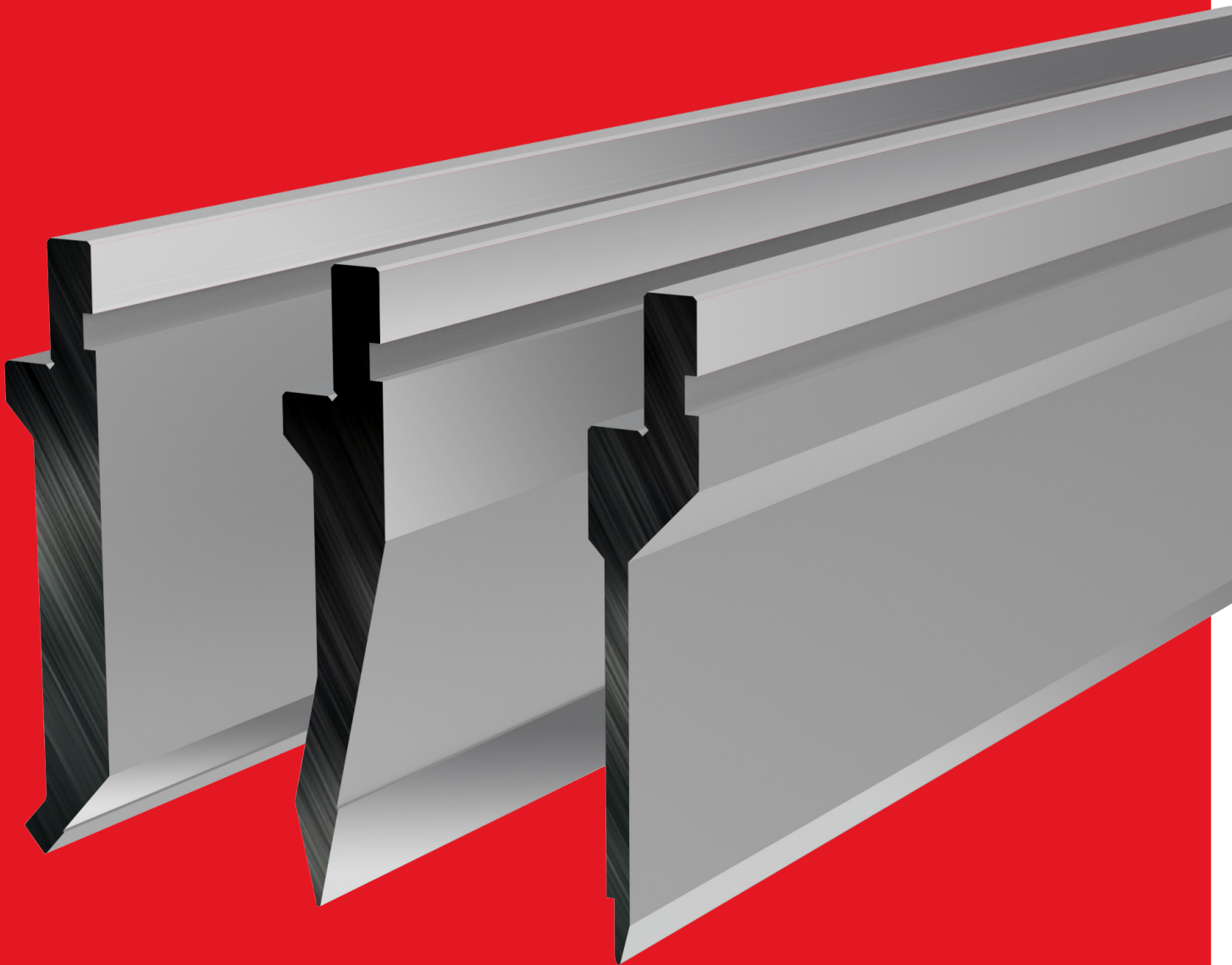

## RED LINE

AMADA - AFH STYLE



# PUNZONI / PUNCHES *AMADA - AFH STYLE*

I PUNZONI STANDARD SONO DISPONIBILI A MAGAZZINO NELLE LUNGHEZZE DI: 415 / 835 E FRAZIONATI (800 mm)  
 THE PUNCHES ARE AVAILABLE IN THE FOLLOWING STANDARD LENGTHS: 415 / 835 AND SECTIONED (800 mm)

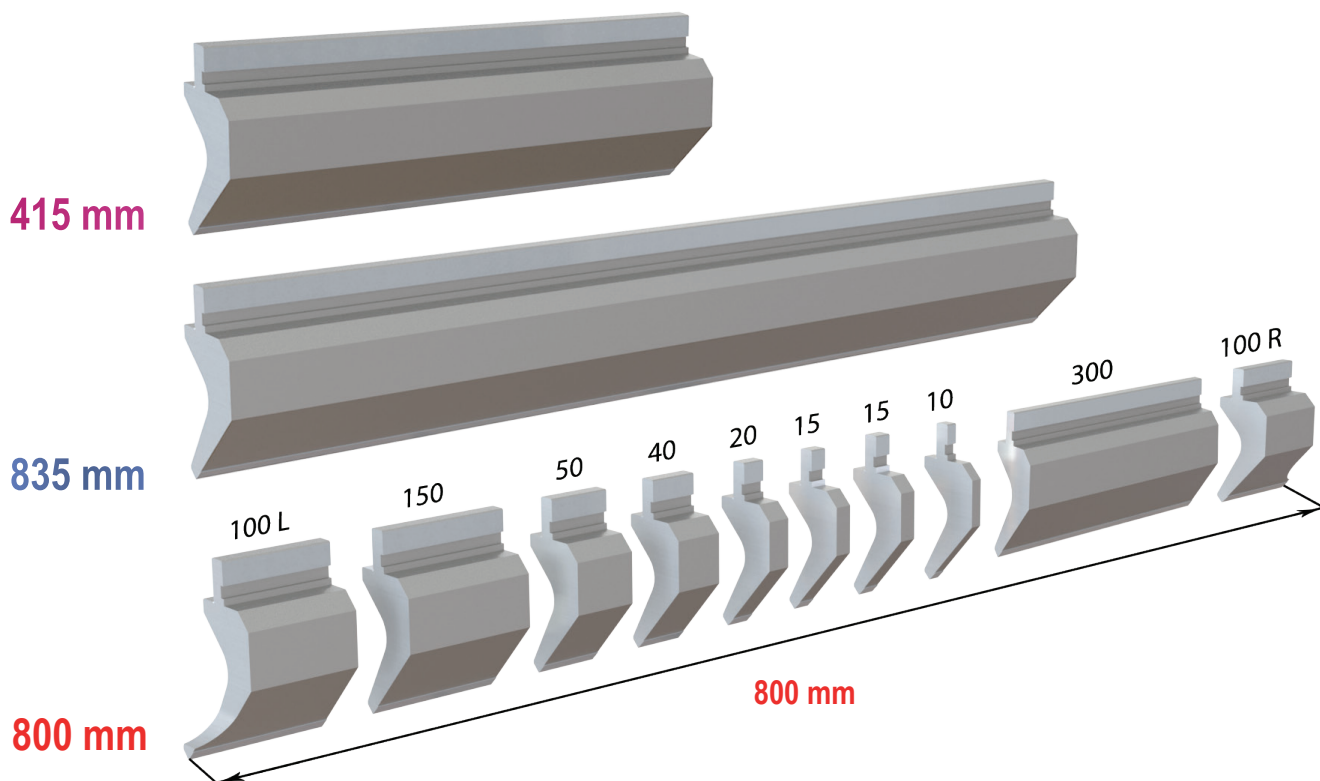

IL CARICO MASSIMO DELLE SCARPETTE CORRISPONDE AL 50% DEL CARICO MASSIMO INDICATO SUL PUNZONE.  
 THE MAX LOAD OF THE HORN EXTENSIONS IS 50% OF THE MAX LOAD OF THE PUNCH.

CODE		
12.022	12.023	12.024
12.027	12.028	12.029
12.035	12.039	12.040
12.041	12.042	

CODE		
12.032	12.033	12.043

CODE		
12.037		

CODE		
12.044	12.045	12.046
12.047	12.048	

CODE		
12.049	12.050	

# PUNZONI / PUNCHES *AMADA - AFH STYLE* 60° / 86°

## VANTAGGI UTENSILI AMADA AFH:

Gli utensili "AFH" sono progettati per consentire all'operatore di fabbricare prodotti che richiedono punzoni con profili diversi montandoli affiancati su un'unica tavola. Inoltre scegliendo di utilizzare la nostra gamma di inserti matrice (Pag.37), sarà possibile incrementare l'efficienza e ridurre i costi di produzione per piccoli lotti, semplificando complicate sequenze di piega e maneggiando il prodotto una sola volta.

## ADVANTAGES OF AMADA AFH TOOLS:

Our "AFH" tools are designed in order to enable the operator to setup multiple bends within one brake bed. Also by choosing our range of inserts dies (Pag.37), it will be possible to increase efficiency and reduce production costs for small batches, simplifying complicated bending sequences and handling the product only once.

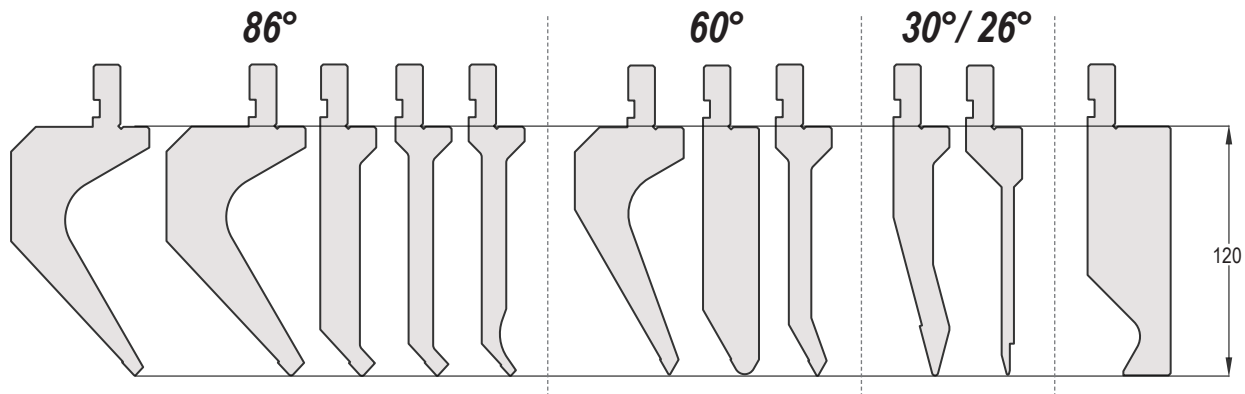

CODE	$\alpha$	R	H	T/Mt	Mt
12.022	86°	0.60	120.00	100	■
12.023	86°	1.50	120.00	100	■
12.024	86°	3.00	120.00	100	■

CODE	$\alpha$	R	H	T/Mt	Mt
12.027	86°	0.60	120.00	50	■
12.028	86°	1.50	120.00	50	■
12.029	86°	3.00	120.00	50	■

CODE	$\alpha$	R	H	T/Mt	Mt
12.032	86°	0.60	120.00	50	■
12.033	86°	1.50	120.00	50	■

CODE	$\alpha$	R	H	T/Mt	Mt
12.035	86°	0.60	120.00	45	■

CODE	$\alpha$	R	H	T/Mt	Mt
12.037	86°	0.60	120.00	30	■

CODE	$\alpha$	R	H	T/Mt	Mt
12.039	60°	0.60	120.00	70	■
12.040	60°	1.50	120.00	70	■

# PUNZONI / PUNCHES *AMADA - AFH STYLE* 26° / 30° / 60°

CODE	$\alpha$	R	H	T/Mt	Mt
12.041	60°	0.60	120.00	70	■
12.042	60°	1.50	120.00	70	■

415 mm  
835 mm  
800 mm SECTIONED

CODE	$\alpha$	R	H	T/Mt	Mt
12.049	60°	5.00	120.00	100	■
12.050	60°	6.00	120.00	100	■

415 mm  
835 mm  
800 mm SECTIONED

CODE	$\alpha$	R	H	T/Mt	Mt
12.043	30°	0.60	120.00	45	■

415 mm  
835 mm  
800 mm SECTIONED

CODE	$\alpha$	R	H	T/Mt	Mt
12.044	26°	0.60	120	100	■
12.045	30°	0.60	120	100	■
12.046	30°	1.50	120	100	■
12.047	30°	3.00	120	100	■
12.048	30°	4.00	120	100	■

415 mm  
835 mm  
800 mm SECTIONED

CODE	H	T/Mt	Mt
12.051	120.00	45	■

FRAZIONATO SENZA SCARPETTE  
SECTIONED WITHOUT HORNS

415 mm  
835 mm  
800 mm SECTIONED



# AMADA - PROMECAM STYLE

PUNZONE ROTANTE  
E SCARPETTE MOBILI

ROTARY PUNCH  
AND MOVING HORNS

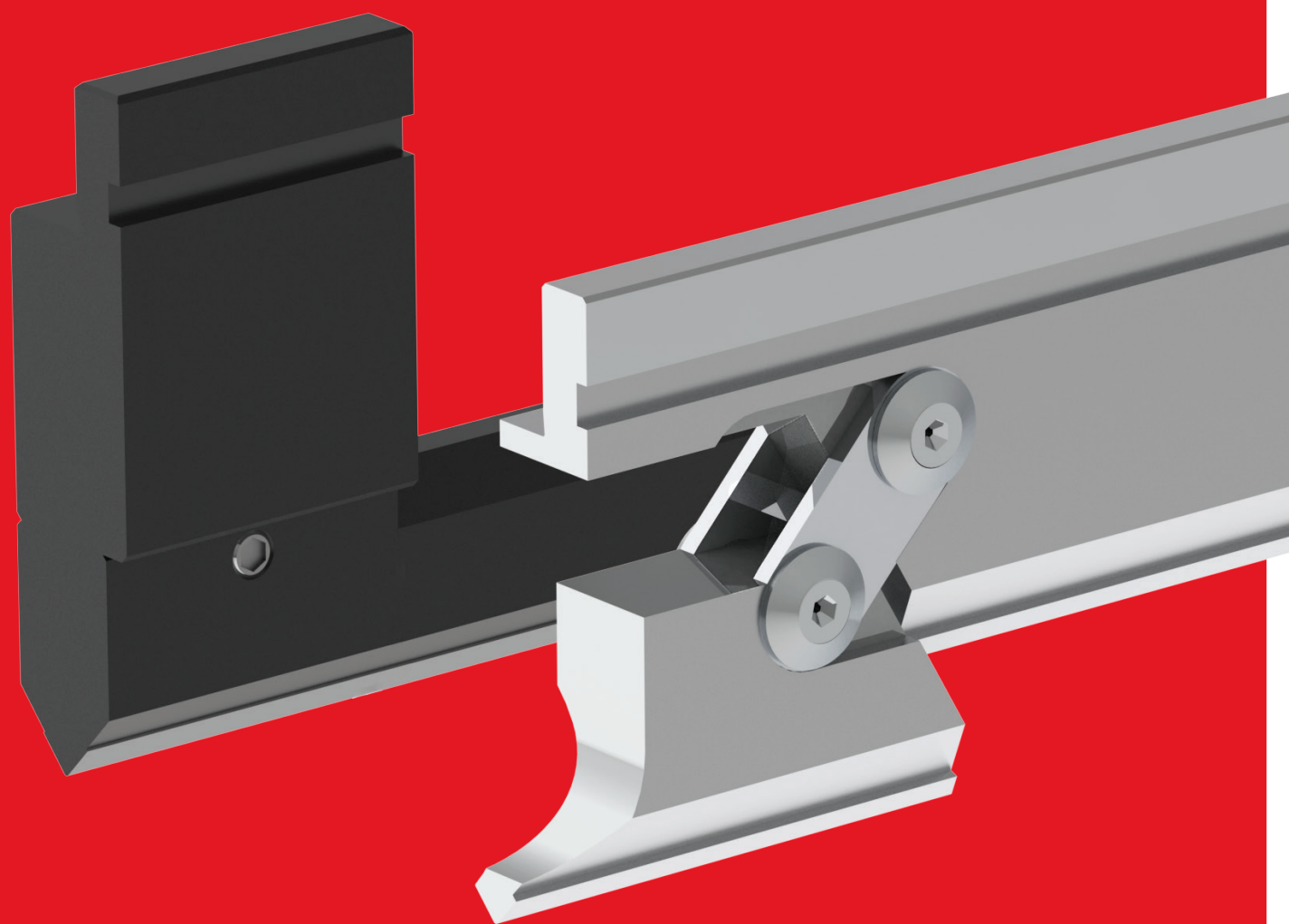

## RED LINE

AMADA - PROMECAM STYLE



# PUNZONE ROTANTE / ROTARY PUNCH *AMADA - PROMECAM STYLE*

CODE	$\alpha$	R	H	T/Mt	Mt
40.680	85°	0.80	110.00	15	<span style="background-color: green; color: white;"> </span>

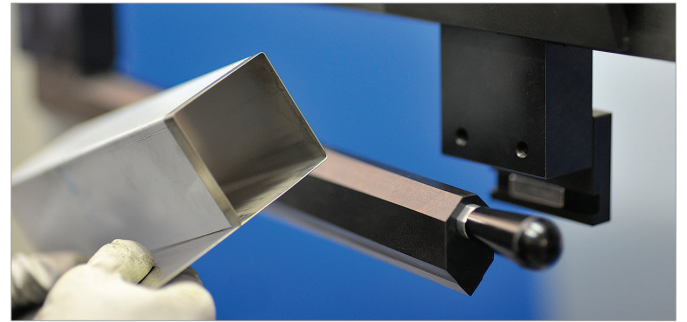
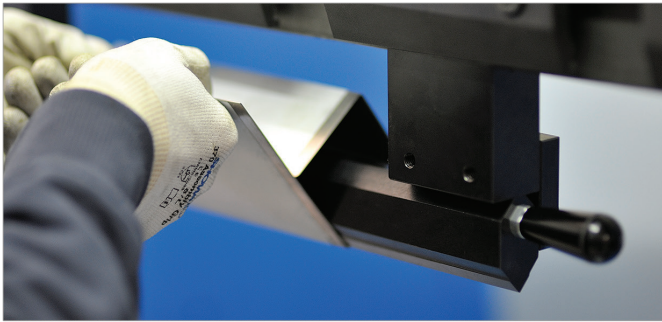
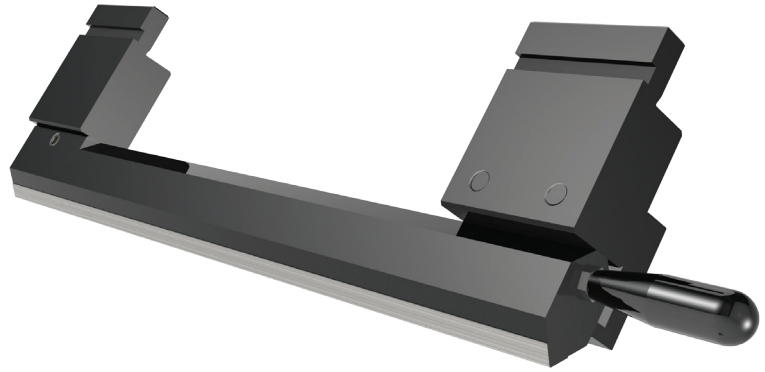
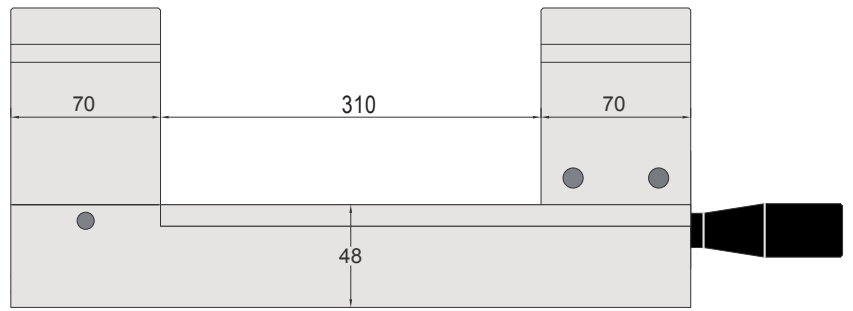
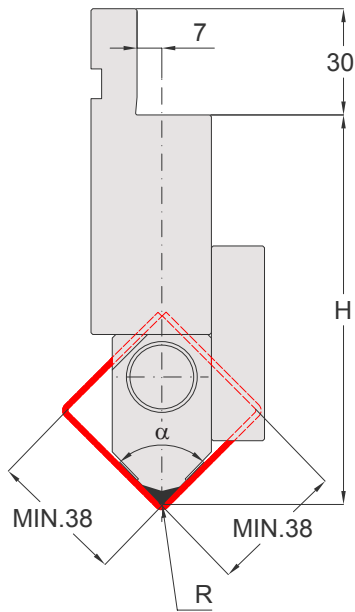

# SCARPETTE MOBILI / MOVING HORNS *AMADA - PROMECAM STYLE*

SCARPETTE MOBILI MOVING HORNS		PUNZONI PUNCHES
40.114	➔	11.200
40.116	➔	11.201
40.122	➔	10.170

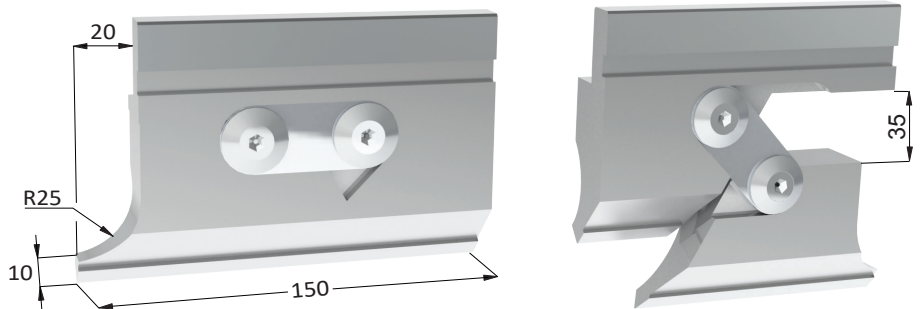

IL CARICO MASSIMO DELLE SCARPETTE CORRISPONDE AL 50% DEL CARICO MASSIMO INDICATO SUL PUNZONE.  
 THE MAX LOAD OF THE HORN EXTENSIONS IS 50% OF THE MAX LOAD OF THE PUNCH.

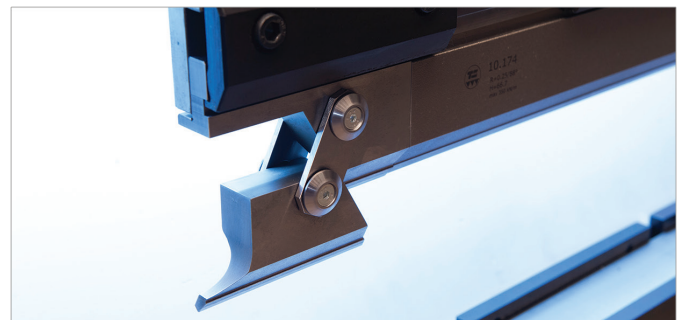
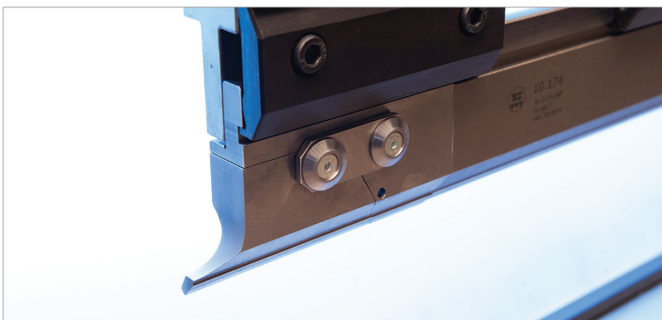

ADATTE ALL'ESECUZIONE DI SCATOLE E IDONEE PER LE ISOLE ROBOTIZZATE  
 SUITABLE TO BOXES PRODUCTION AND ROBOT BENDING CELLS

# AMADA - PROMECAM STYLE

MATRICI

DIES

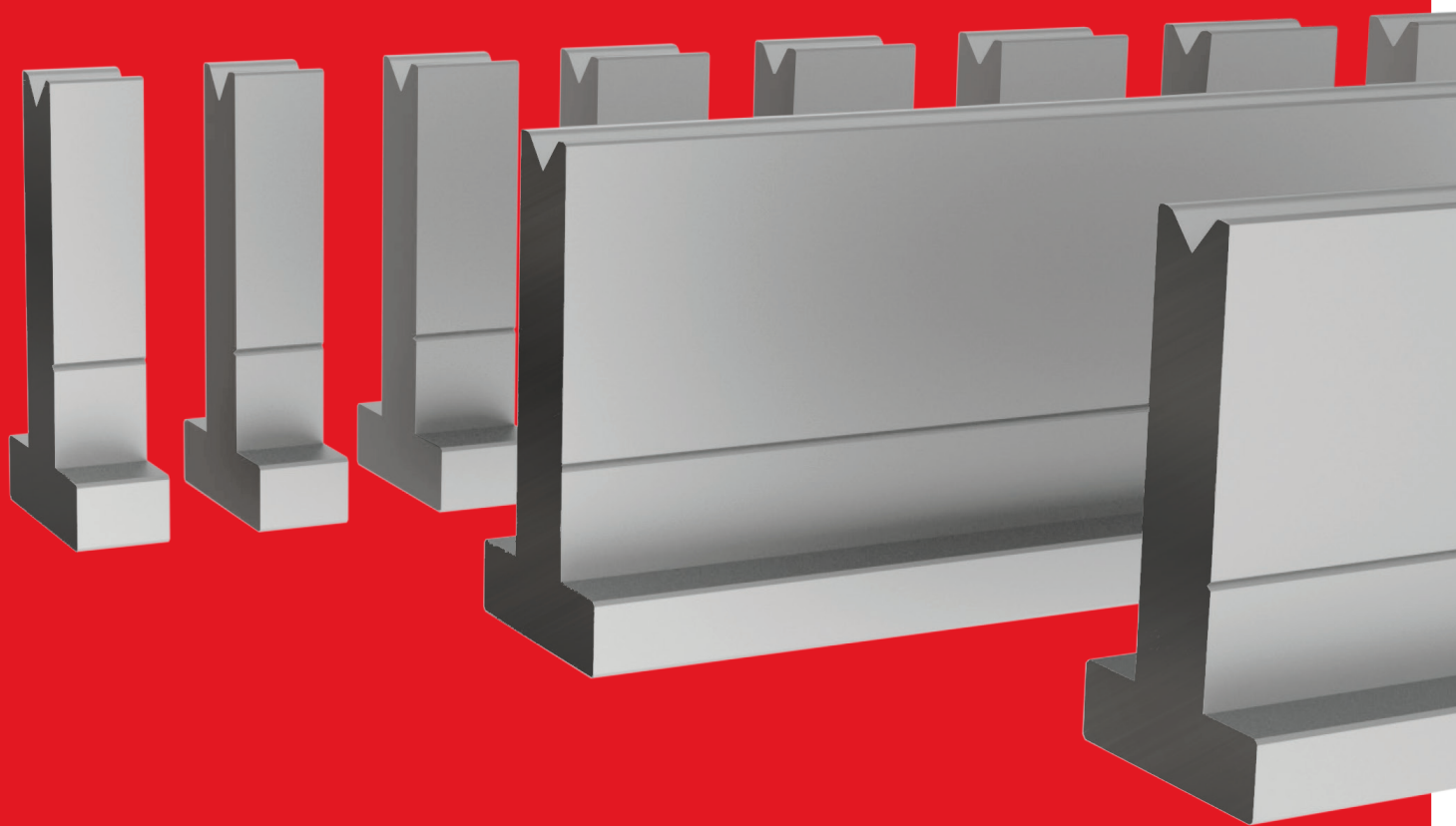

## RED LINE

AMADA - PROMECAM STYLE



# MATRICI / DIES *AMADA - PROMECAM STYLE* 2V / 4V

LE MATRICI STANDARD SONO DISPONIBILI A MAGAZZINO NELLE LUNGHEZZE DI: 415 / 835 E FRAZIONATI (800 mm)  
 THE DIES ARE AVAILABLE IN THE FOLLOWING STANDARD LENGTHS: 415 / 835 AND SECTIONED (800 mm)

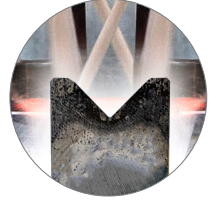

TEMPRA AD INDUZIONE 52-55 HRC  
 INDUCTION HARDENED 52-55 HRC

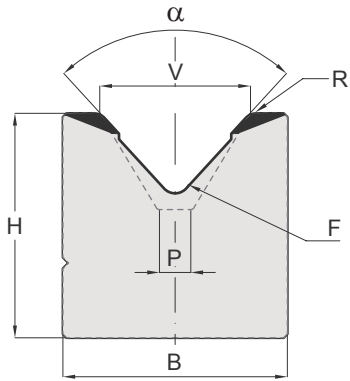

415 mm



835 mm

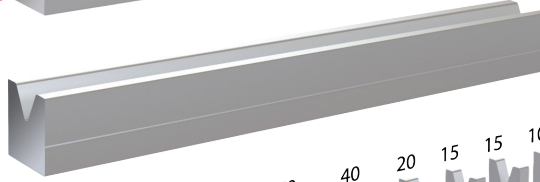

800 mm

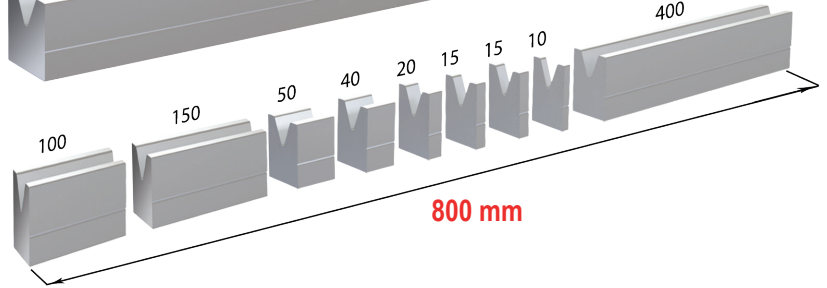

<b>LEGENDA</b>	$\alpha$ = ANGOLO	V = AMPIEZZA CAVA	R = RAGGIO	H = ALTEZZA	F = FONDO MATRICE	P = PIANO	B = BASE
<b>LEGEND</b>	$\alpha$ = ANGLE	V = DIE OPENING	R = RADIUS	H = HEIGHT	F = BOTTOM DIES	P = FLAT	B = BASE

CODE	T/Mt	Mt
21.209	100	<span style="background-color: green; color: white;">■</span>

415 mm  
 835 mm  
 800 mm SECTIONED

CODE	$\alpha$	T/Mt	Mt
20.350	60°	60	<span style="background-color: green; color: white;">■</span>

415 mm  
 835 mm  
 800 mm SECTIONED

CODE	$\alpha$	T/Mt	Mt
21.207	85°	80	<span style="background-color: green; color: white;">■</span>

415 mm  
 835 mm  
 800 mm SECTIONED

CODE	$\alpha$	H	T/Mt	Mt
20.820	85°	80.00	100	<span style="background-color: green; color: white;">■</span>

415 mm  
 835 mm  
 800 mm SECTIONED

CODE	$\alpha$	H	T/Mt	Mt
20.830	30°	80.00	100	<span style="background-color: green; color: white;">■</span>

415 mm  
 835 mm  
 800 mm SECTIONED

CODE	$\alpha$	H	T/Mt	Mt
28.820	60° - 80°	90	80	<span style="background-color: green; color: white;">■</span>

415 mm  
 835 mm  
 800 mm SECTIONED

CODE	H	T/Mt	Mt
20.240	80.00	100	<span style="background-color: yellow;"> </span>

415 mm  
835 mm  
800 mm SECTIONED

CODE	$\alpha$	V	R	H	T/Mt	Mt
20.210	85°	32	4.00	60.00	100	<span style="background-color: green;"> </span>

415 mm  
835 mm  
800 mm SECTIONED

CODE	$\alpha$	V	R	H	T/Mt	Mt
20.211	85°	40	4.00	60.00	100	<span style="background-color: green;"> </span>

415 mm  
835 mm  
800 mm SECTIONED

CODE	$\alpha$	V	R	H	T/Mt	Mt
20.212	85°	50	4.00	60.00	100	<span style="background-color: green;"> </span>

415 mm  
835 mm  
800 mm SECTIONED

CODE	$\alpha$	V	R	H	T/Mt	Mt
20.484	45°	32	4.00	80.00	100	<span style="background-color: green;"> </span>

415 mm  
835 mm  
800 mm SECTIONED

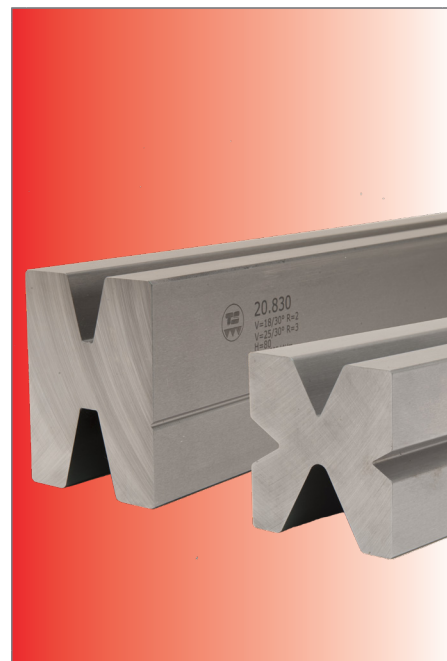

CODE	$\alpha$	V	R	H	T/Mt	Mt
20.440	45°	40	4.00	75.00	100	<span style="background-color: green;"> </span>

415 mm  
835 mm  
800 mm SECTIONED

CODE	$\alpha$	V	R	H	T/Mt	Mt
20.650	60°	50	5.00	75.00	100	<span style="background-color: green;"> </span>

415 mm  
835 mm  
800 mm SECTIONED

CODE	$\alpha$	V	R	H	T/Mt	Mt
20.370	60°	63	5.00	86.00	100	<span style="background-color: green;"> </span>

415 mm  
835 mm  
800 mm SECTIONED

CODE	$\alpha$	V	R	H	T/Mt	Mt
20.213	85°	63	5.00	75.00	100	

415 mm  
835 mm  
800 mm SECTIONED

CODE	$\alpha$	V	R	H	T/Mt	Mt
20.214	85°	80	6.00	80.00	100	

415 mm  
835 mm  
800 mm SECTIONED

CODE	$\alpha$	V	R	H	T/Mt	Mt
20.680	60°	80	6.00	115.00	100	

415 mm  
835 mm  
800 mm SECTIONED

CODE	$\alpha$	V	R	H	T/Mt	Mt
20.610	60°	100	10.00	130.00	100	

415 mm  
835 mm  
800 mm SECTIONED

CODE	$\alpha$	V	R	H	T/Mt	Mt
20.215	85°	100	7.00	95.00	100	

415 mm  
835 mm  
800 mm SECTIONED

CODE	$\alpha$	V	R	H	T/Mt	Mt
20.216	80°	125	9.00	103.00	150	

200 mm  
415 mm  
800 mm SECTIONED

CODE	$\alpha$	V	R	H	T/Mt	Mt
20.380	45°	80	6.00	145.00	100	

200 mm  
415 mm  
800 mm SECTIONED

CODE	$\alpha$	V	R	H	T/Mt	Mt
20.217	80°	160	10.00	130.00	150	

200 mm  
415 mm  
800 mm SECTIONED

CODE	$\alpha$	V	R	H	T/Mt	Mt
21.125	80°	125	9.00	103.00	150	■

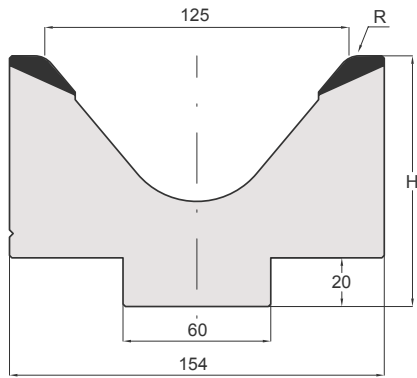

200 mm  
415 mm  
800 mm  
SECTIONED

CODE	$\alpha$	V	R	H	T/Mt	Mt
21.160	80°	160	10.00	130.00	150	■

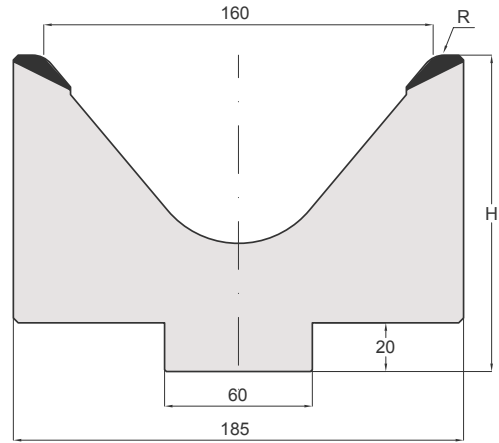

200 mm  
415 mm  
800 mm  
SECTIONED

CODE	$\alpha$	V	R	H	T/Mt	Mt
21.200	70°	200	15.00	185.00	200	■

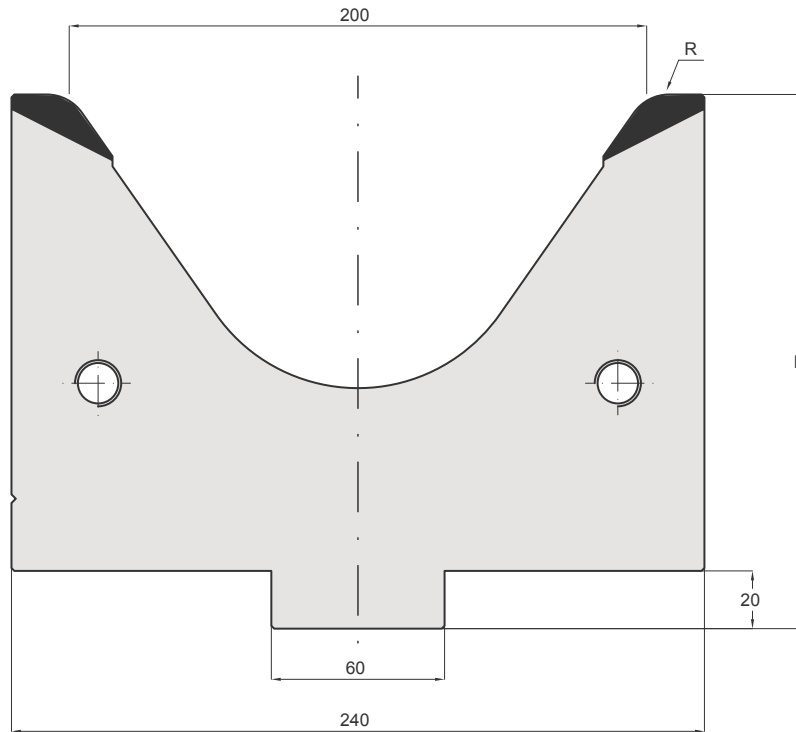

200 mm  
415 mm

# MATRICI / DIES AMADA - PROMECAM STYLE H=80

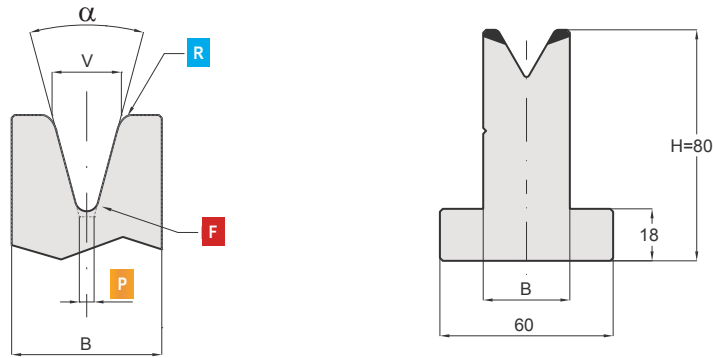

415 mm | 835 mm | 800 mm SECTIONED

LE MATRICI STANDARD SONO DISPONIBILI A MAGAZZINO NELLE LUNGHEZZE DI: 415 mm - 835 mm E FRAZIONATI (800 mm)  
 THE DIES ARE AVAILABLE IN THE FOLLOWING STANDARD LENGTHS: 415 mm - 835 mm AND SECTIONED (800 mm)

<b>LEGENDA</b>	$\alpha$ = ANGOLO	V = AMPIEZZA CAVA	R = RAGGIO	H = ALTEZZA	B = STELO	F = FONDO MATRICE	P = PIANO
<b>LEGEND</b>	$\alpha$ = ANGLE	V = DIE OPENING	R = RADIUS	H = HEIGHT	B = BODY	F = BOTTOM DIE	P = FLAT

CODE	$\alpha$	V	R	H	B	F	T/mt	Mt
20.506	85°	6	1.50	80	14	R0.5	100	■
20.508	85°	8	2.00	80	14	R0.5	100	■
20.510	85°	10	2.50	80	18	R0.5	100	■
20.512	85°	12	3.00	80	18	R0.5	100	■
20.516	85°	16	3.50	80	24	R0.5	100	■
20.520	85°	20	4.00	80	30	R1.0	100	■
20.525	85°	25	5.00	80	35	R1.0	100	■
20.297	60°	6	0.40	80	14	R0.5	60	■
20.298	60°	8	0.50	80	14	R0.5	60	■
20.299	60°	10	0.60	80	18	R0.5	60	■
20.300	60°	12	0.80	80	18	R0.5	60	■
20.301	60°	16	1.60	80	24	R0.7	60	■
20.308	60°	20	2.00	80	30	R1.0	60	■
20.311	60°	25	3.00	80	35	R1.0	60	■
20.406	35°	6	1.50	80	14	R1.0	40	■
20.408	35°	8	2.00	80	18	P2.0	40	■
20.410	35°	10	2.50	80	24	P2.0	55	■
20.412	35°	12	3.00	80	24	P2.0	45	■
20.416	35°	16	3.50	80	30	P2.0	50	■
20.420	35°	20	4.00	80	35	P5.0	60	■
20.425	35°	25	5.00	80	40	P5.0	60	■
20.317	30°	6	0.60	80	14	R1.0	35	■
20.318	30°	8	0.80	80	18	P2.0	35	■
20.319	30°	10	1.00	80	24	P2.0	50	■
20.320	30°	12	1.50	80	24	P2.0	40	■
20.321	30°	16	2.00	80	30	P5.0	45	■
20.322	30°	20	2.50	80	35	P5.0	50	■
20.323	30°	25	3.00	80	40	P5.0	50	■



# MATRICI / DIES AMADA - PROMECAM STYLE H=120

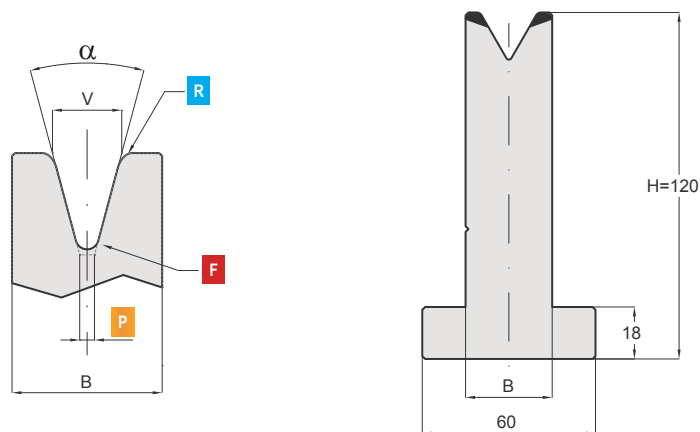

415 mm | 835 mm | 800 mm SECTIONED

LE MATRICI STANDARD SONO DISPONIBILI A MAGAZZINO NELLE LUNGHEZZE DI: 415 mm - 835 mm E FRAZIONATI (800 mm)  
 THE DIES ARE AVAILABLE IN THE FOLLOWING STANDARD LENGTHS: 415 mm - 835 mm AND SECTIONED (800 mm)

<b>LEGENDA</b>	$\alpha$ = ANGOLO	V = AMPIEZZA CAVA	R = RAGGIO	H = ALTEZZA	B = STELO	F = FONDO MATRICE	P = PIANO
<b>LEGEND</b>	$\alpha$ = ANGLE	V = DIE OPENING	R = RADIUS	H = HEIGHT	B = BODY	F = BOTTOM DIE	P = FLAT

CODE	$\alpha$	V	R	H	B	F	T/mt	Mt
21.506	85°	6	1.50	120	14	R0.5	100	■
21.508	85°	8	2.00	120	14	R0.5	100	■
21.510	85°	10	2.50	120	18	R0.5	100	■
21.512	85°	12	3.00	120	18	R0.5	100	■
21.516	85°	16	3.50	120	24	R0.5	100	■
21.520	85°	20	4.00	120	30	R1.0	100	■
21.525	85°	25	5.00	120	35	R1.0	100	■
20.386	60°	6	0.40	120	14	R0.5	60	■
20.387	60°	8	0.50	120	14	R0.5	60	■
20.388	60°	10	0.60	120	18	R0.5	60	■
20.389	60°	12	0.80	120	18	R0.5	60	■
20.390	60°	16	1.60	120	24	R0.7	60	■
20.391	60°	20	2.00	120	30	R1.0	60	■
20.392	60°	25	3.00	120	35	R1.0	60	■
21.406	35°	6	1.50	120	14	R1.0	40	■
21.408	35°	8	2.00	120	18	P2.0	40	■
21.410	35°	10	2.50	120	24	P2.0	55	■
21.412	35°	12	3.00	120	24	P2.0	45	■
21.416	35°	16	3.50	120	30	P2.0	50	■
21.420	35°	20	4.00	120	35	P5.0	60	■
21.425	35°	25	5.00	120	40	P5.0	60	■
20.351	30°	6	0.60	120	14	R1.0	35	■
20.352	30°	8	0.80	120	18	P2.0	35	■
20.353	30°	10	1.00	120	24	P2.0	50	■
20.354	30°	12	1.50	120	24	P2.0	40	■
20.401	30°	16	2.00	120	30	P5.0	45	■
20.402	30°	20	2.50	120	35	P5.0	50	■
20.403	30°	25	3.00	120	40	P5.0	50	■

CODE	H1	H2	T/Mt	Mt
20.200	34.00	20.00	100	■

412 mm  
830 mm

CODE	H1	H2	T/Mt	Mt
20.201	55.00	35.00	100	■

412 mm  
830 mm

CODE	H1	H2	T/Mt	Mt
20.306	75.00	55.00	100	■

412 mm  
830 mm

CODE	H1	H2	T/Mt	Mt
20.316	39.00	20.00	100	■

412 mm  
830 mm

CODE	H1	T/Mt	Mt
20.287	10.00	100	■

412 mm  
830 mm

CODE	H1	T/Mt	Mt
20.400	20.00	100	■

412 mm  
830 mm

CODE	Mt
20.336	■

## SCHEMA DI MONTAGGIO - ASSEMBLY SCHEME

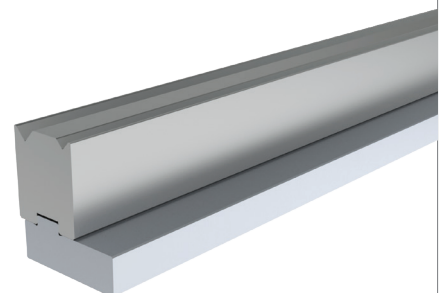
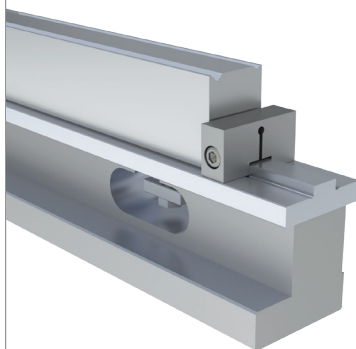
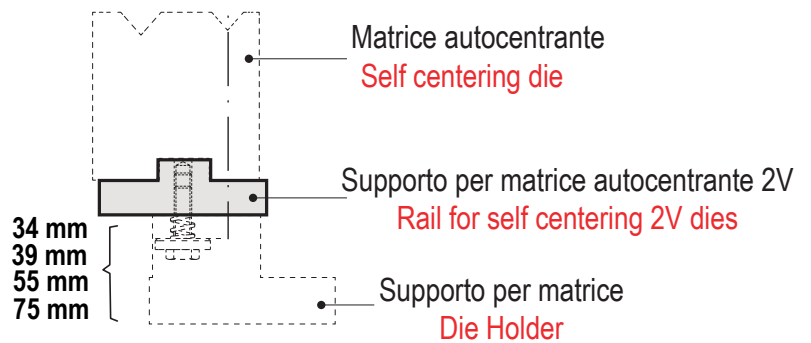

# MATRICI / DIES *AMADA - PROMECAM STYLE* 2V - H=46

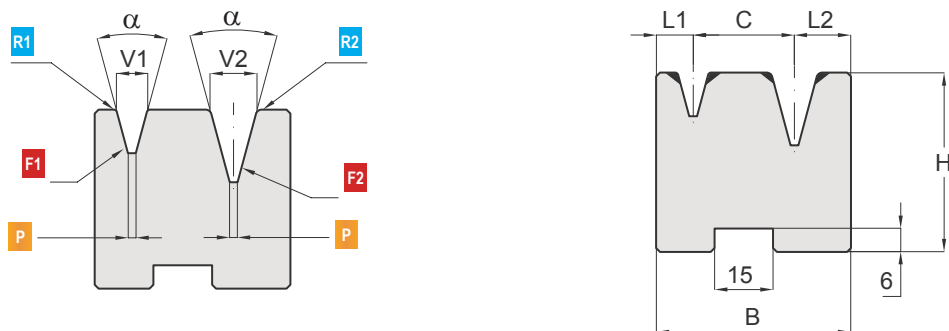

415 mm | 835 mm | 800 mm SECTIONED

LE MATRICI STANDARD SONO DISPONIBILI A MAGAZZINO NELLE LUNGHEZZE DI: 415 mm - 835 mm E FRAZIONATI (800 mm)  
 THE DIES ARE AVAILABLE IN THE FOLLOWING STANDARD LENGTHS: 415 mm - 835 mm AND SECTIONED (800 mm)

<b>LEGENDA</b>	$\alpha$ = ANGOLO	V = AMPIEZZA CAVA	R1 / R2 = RAGGIO	H = ALTEZZA	B = STELO	F1 / F2 = FONDO MATRICE	P = PIANO
<b>LEGEND</b>	$\alpha$ = ANGLE	V = DIE OPENING	R1 / R2 = RADIUS	H = HEIGHT	B = BODY	F1 / F2 = BOTTOM DIE	P = FLAT

CODE	$\alpha$	V1	V2	R1	R2	F1	F2	L1	L2	H	B	C	T/Mt	Mt
20.344	85°	4	7	0.60	1.00	R0.5	R0.5	3.50	5.00	46	34.5	26	80	
20.345	85°	6	10	1.00	1.50	R0.5	R0.5	4.50	6.50	46	37	26	80	
20.346	85°	8	12	1.20	1.75	R0.5	R0.5	5.50	7.50	46	39	26	80	
20.347	85°	12	20	1.75	2.50	R0.5	R0.5	7.50	12.00	46	45.5	26	80	
20.349	85°	14	18	1.50	2.00	R0.5	R0.5	8.50	10.50	46	45	26	80	
20.348	85°	16	25	2.00	3.00	R0.5	R1.0	9.50	14.50	46	50	26	80	
20.438	30°	6	10	0.60	1.00	R1.0	P2.0	7.00	12.00	46	45	26	40	
20.478	30°	8	12	0.80	1.50	P2.0	P2.0	9.50	14.50	46	50	26	40	

ELENCO - LIST - LISTADO - LISTA - LISTE - LISTE

20.344



20.347



20.438



20.345



20.348



20.478



20.346



20.349



# SUPPORTI MATRICE / DIE HOLDERS *AMADA - PROMECAM STYLE*

BLOCCAGGIO STANDARD - 8 VITI  
 NORMAL LOCKING - 8 SCREWS

CODE	Mt
22.010	

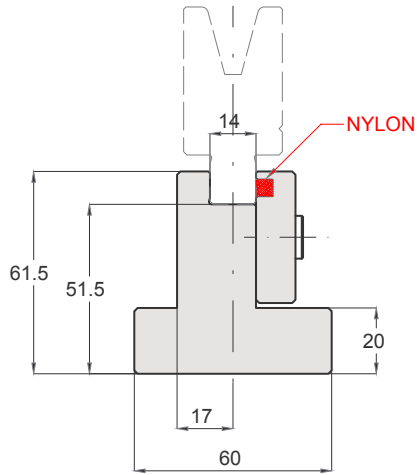

415 mm  
 835 mm



BLOCCAGGIO VELOCE - 2 VITI  
 FAST LOCKING - 2 SCREWS

CODE	Mt
22.020	



**BLOCCAGGIO RAPIDO**  
**FAST LOCKING**

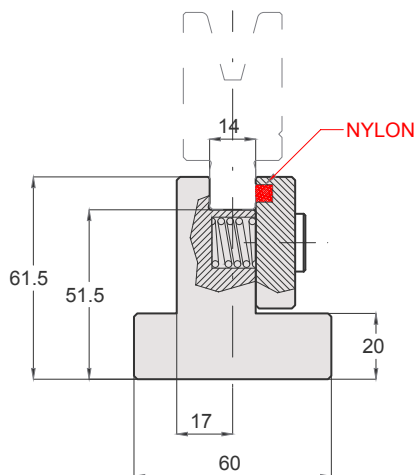

415 mm  
 835 mm



# INSERTI MATRICE / DIE INSERTS **AMADA - PROMECAM STYLE**

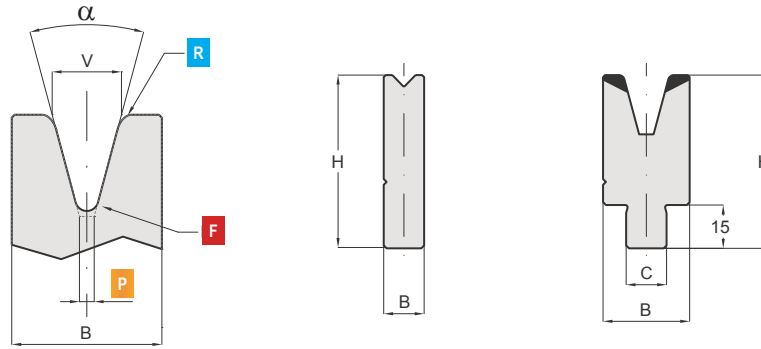

415 mm | 835 mm | 800 mm SECTIONED

LE MATRICI STANDARD SONO DISPONIBILI A MAGAZZINO NELLE LUNGHEZZE DI: 415 mm - 835 mm E FRAZIONATI (800 mm)  
 THE DIES ARE AVAILABLE IN THE FOLLOWING STANDARD LENGTHS: 415 mm - 835 mm AND SECTIONED (800 mm)

<b>LEGENDA</b>	$\alpha$ = ANGOLO	V = AMPIEZZA CAVA	R = RAGGIO	H = ALTEZZA	B = STELO	C = CODOLO	F = FONDO MATRICE	P = PIANO
<b>LEGEND</b>	$\alpha$ = ANGLE	V = DIE OPENING	R = RADIUS	H = HEIGHT	B = BODY	C = TANG	F = BOTTOM DIE	P = FLAT

CODE	$\alpha$	V	R	H	B	C	F	T/mt	Mt
22.904	86°	4	1.00	60	10	14	R0.5	75	■
22.906	86°	6	1.50	60	11	14	R0.5	80	■
22.908	86°	8	1.50	60	12	14	R1.0	90	■
22.910	86°	10	2.00	60	13.5	14	R1.0	100	■
22.912	86°	12	2.50	60	15	14	R1.0	100	■
22.914	86°	14	2.50	60	17	14	R1.0	100	■
22.916	86°	16	2.50	60	20	14	R1.0	100	■
22.918	86°	18	2.50	60	22	14	R1.0	100	■
22.920	86°	20	2.50	60	24.4	14	R1.0	100	■
22.925	86°	25	3.00	60	29.6	14	R2.0	100	■
22.832	84°	32	4.00	60	38	14	R2.0	100	■
22.840	84°	40	4.00	60	46	14	R2.0	100	■
22.606	60°	6	0.60	60	12	14	R0.6	38	■
22.608	60°	8	0.80	60	13.5	14	R0.8	45	■
22.610	60°	10	1.00	60	16	14	R1.0	55	■
22.612	60°	12	1.20	60	17	14	R1.0	55	■
22.616	60°	16	1.60	60	22	14	R1.0	65	■
22.620	60°	20	2.00	60	28	14	R1.0	85	■
22.625	60°	25	2.50	60	31	14	R1.0	85	■
22.432	45°	32	5.00	80	50	14	R5.0	100	■
22.440	45°	40	5.00	80	60	14	R5.0	100	■
22.306	30°	6	0.60	60	14	14	R1.0	35	■
22.308	30°	8	0.80	60	18	14	P2.0	35	■
22.310	30°	10	1.00	60	24	14	P2.0	50	■
22.312	30°	12	1.50	60	24	14	P2.0	40	■
22.316	30°	16	2.00	60	30	14	P5.0	45	■
22.320	30°	20	2.50	60	35	14	P5.0	50	■
22.325	30°	25	3.00	65	45	14	P8.0	50	■

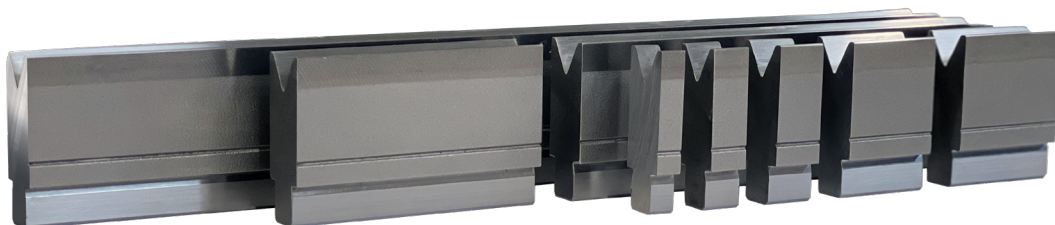



# AMADA - PROMECAM STYLE

PIEGASCHIACCIA

HEMMING TOOLS

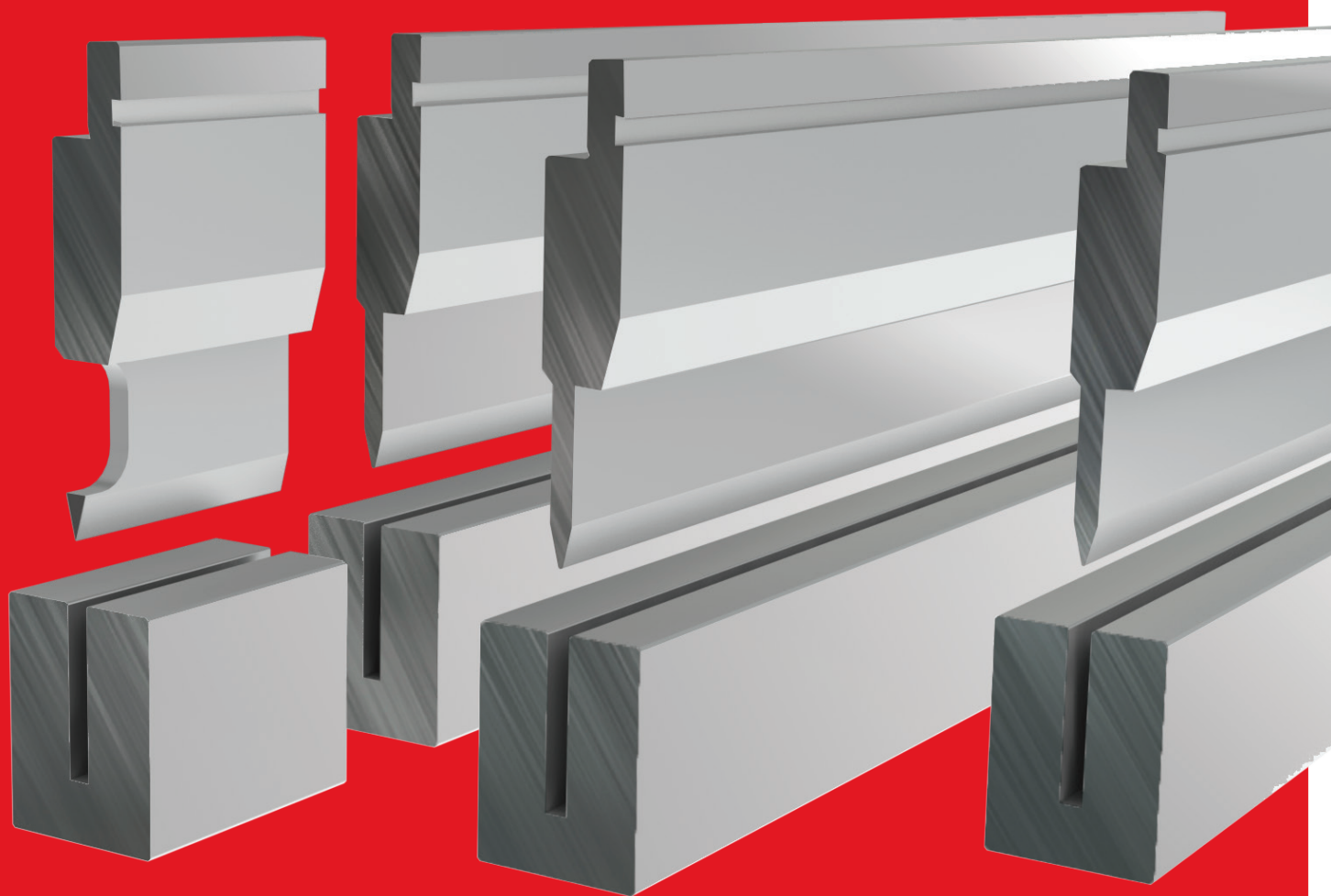

## RED LINE

AMADA - PROMECAM STYLE



# MATRICI PIEGASCHIACCIA / HEMMING DIES **AMADA STYLE**

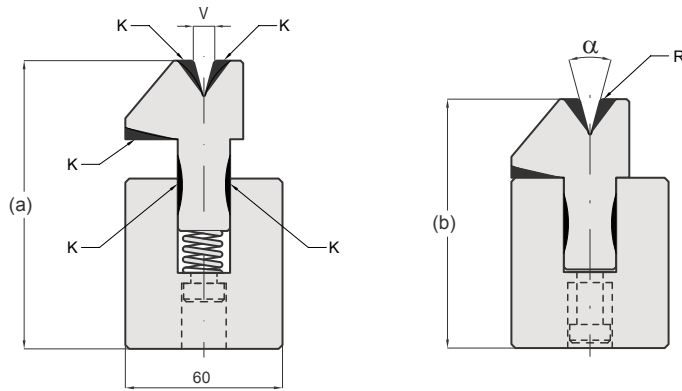

<b>LEGENDA</b>	(a) = APERTO	(b) = CHIUSO	(α) = ANGOLO	V = AMPIEZZA CAVA	R = RAGGIO	K = PARTI USURABILI
<b>LEGEND</b>	(a) = OPEN	(b) = CLOSED	(α) = ANGLE	V = DIE OPENING	R = RADIUS	K = WEAR PARTS

415 mm | 835 mm

CODE	α	V	R	T/Mt	Mt
20.264	35°	6	1.00	60	

Max sp 1mm  
Max tk 1mm  
415 mm  
835 mm

CODE	α	V	R	T/Mt	Mt
20.303	30°	8	1.50	80	

Max sp 1,5mm  
Max tk 1,5mm  
415 mm  
835 mm

CODE	α	V	R	T/Mt	Mt
20.450	30°	8	1.50	60	

Max sp 1,5mm  
Max tk 1,5mm  
415 mm  
835 mm

CODE	α	V	R	T/Mt	Mt
20.231	26°	10	1.50	100	

Max sp 2mm  
Max tk 2mm  
415 mm  
835 mm

CODE	α	V	R	T/Mt	Mt
20.305	26°	12	3.00	100	

Max sp 3mm  
Max tk 3mm  
415 mm  
835 mm

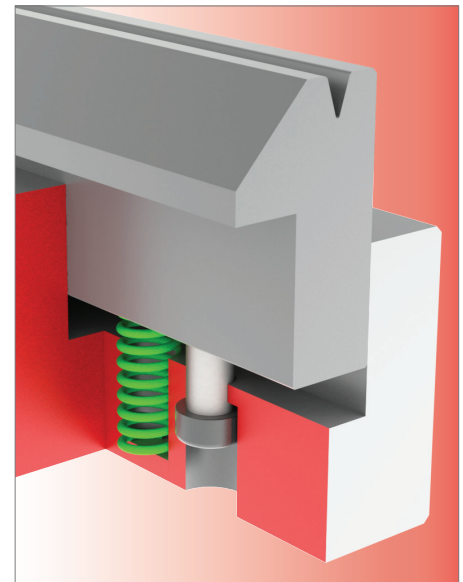

**CODE**  
70.100

**SPARE PARTS**

**CODE**  
70.102

**SPARE PARTS**



# MATRICI PIEGASCHIACCIA PNEUMATICHE / PNEUMATIC HEMMING DIES **AMADA STYLE**

I PIEGASCHIACCIA PNEUMATICI SONO EQUIPAGGIATI CON CILINDRI AD ARIA, RICAVANDONE I SEGUENTI VANTAGGI:

- A) RECUPERO DI 15 MM DI LUCE E DI CORSA CON CONSEGUENTE RIDUZIONE DEI TEMPI DI LAVORAZIONE.
- B) MAGGIOR PRECISIONE DI PIEGA
- C) MINOR USURA DEGLI UTENSILI
- D) COLLEGAMENTO AL CNC

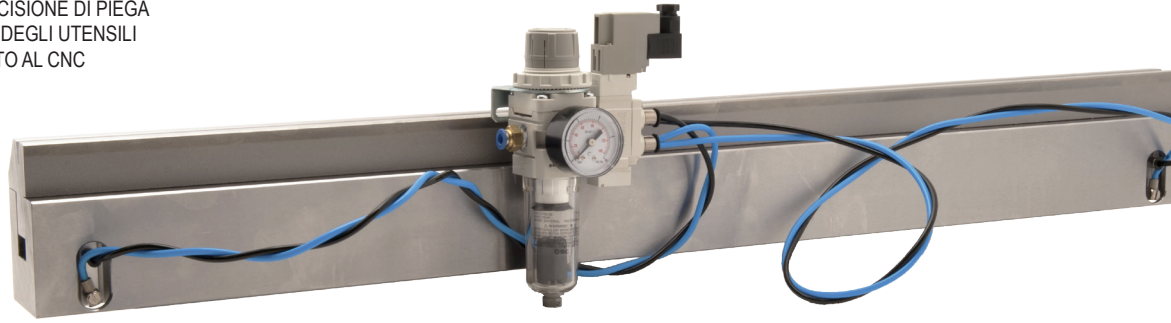

PNEUMATIC FLATTENING DIES ARE EQUIPPED WITH AIR CYLINDERS, GETTING THE FOLLOWING BENEFITS:

- A) SAVING 15 MM LIGHT AND STROKE WITH REDUCTION OF WORKING TIME.
- B) MORE PRECISE BENDING
- C) LESS WEAR
- D) CONNETTABLE TO EXISTING FREE CONTROL-OUTPUT I/O

CODE	$\alpha$	V	R	T/Mt	Mt
21.264	35°	6	1.00	60	

Max sp 1mm  
Max tk 1mm  
415 mm  
835 mm

CODE	$\alpha$	V	R	T/Mt	Mt
21.303	30°	8	1.50	80	

Max sp 1,5mm  
Max tk 1,5mm  
415 mm  
835 mm

CODE	$\alpha$	V	R	T/Mt	Mt
21.450	30°	8	1.50	60	

Max sp 1,5mm  
Max tk 1,5mm  
415 mm  
835 mm

CODE	$\alpha$	V	R	T/Mt	Mt
21.231	26°	10	1.50	100	

Max sp 2mm  
Max tk 2mm  
415 mm  
835 mm

CODE	$\alpha$	V	R	T/Mt	Mt
21.305	26°	12	3.00	100	

Max sp 3mm  
Max tk 3mm  
415 mm  
835 mm

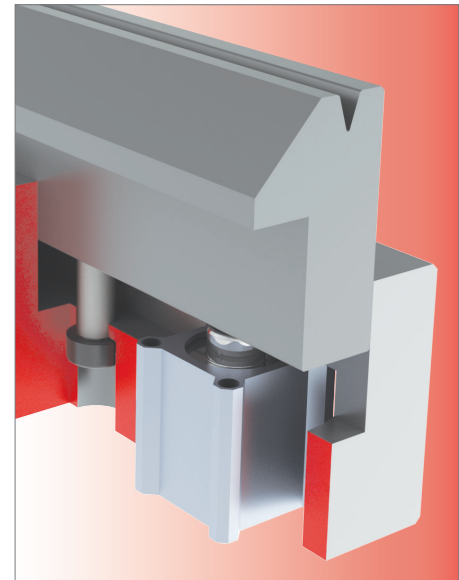

CODE  
50.720

SPARE PARTS

CODE  
70.121

SPARE PARTS

CODE  
70.123

SPARE PARTS

CODE  
70.120

SPARE PARTS

# PIEGASCHIACCIA / HEMMING TOOLS *AMADA - PROMECAM STYLE*

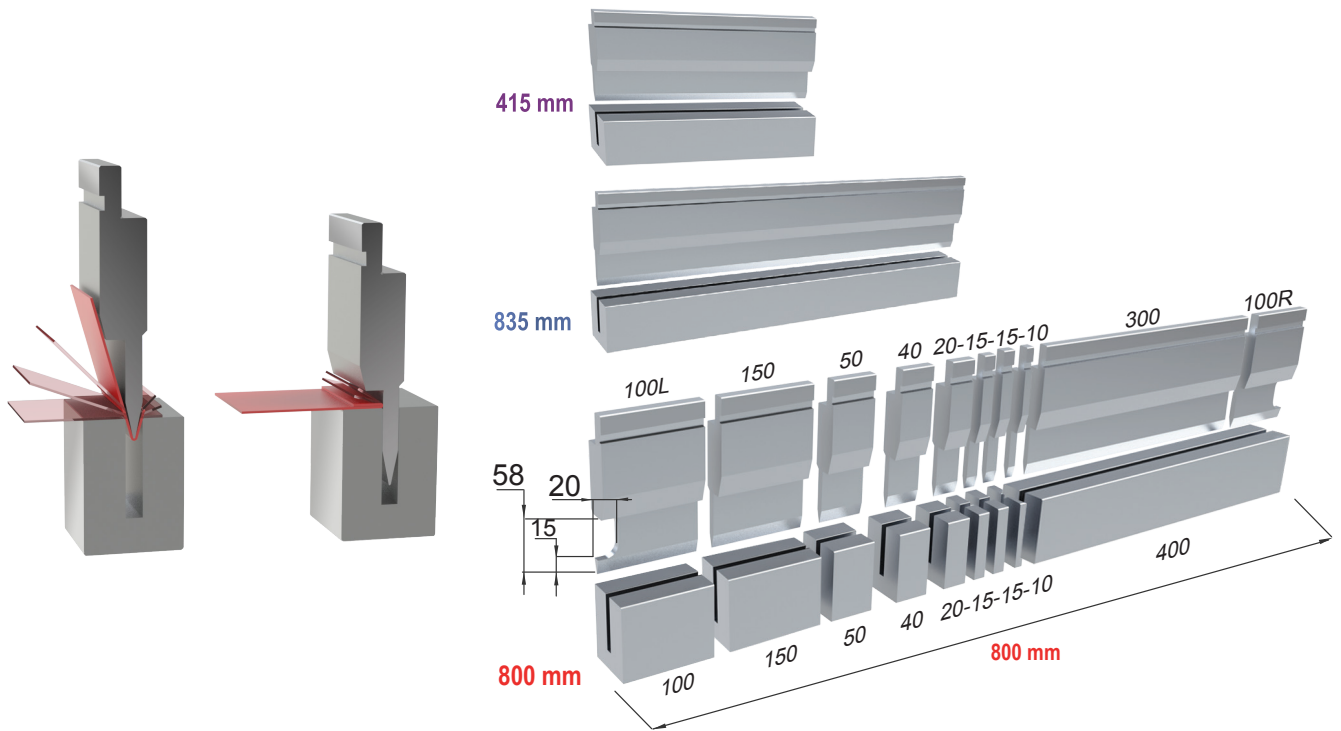

IL CARICO MASSIMO DELLE SCARPETTE CORRISPONDE AL 50% DEL CARICO MASSIMO INDICATO SUL PUNZONE.  
 THE MAX LOAD OF THE HORN EXTENSIONS IS 50% OF THE MAX LOAD OF THE PUNCH.

MATERIAL ACC.R ~ 40 Kg/MM <sup>2</sup>					MATERIAL ACC.R ~ 70 Kg/MM <sup>2</sup>				
MATERIAL ACC.R ~ 40 Kg/MM <sup>2</sup>					MATERIAL ACC.R ~ 70 Kg/MM <sup>2</sup>				
S (mm)	(t/m)	T (mm)	(t/m)	2S(mm)	S (mm)	(t/m)	T (mm)	(t/m)	2S(mm)
0,6	9	3	23	1,2	0,6	15	3	35	1,2
0,8	12	3	32	1,6	0,8	20	3	50	1,6
1,0	15	3,5	40	2,0	1,0	25	3,5	60	2,0
1,25	17	3,5	50	2,5	1,25	26	3,5	80	2,5
1,5	22	4,6	63	3,0	1,5	38	4,6	95	3,0
2,0	30	5,5	80	4,0	2,0	50	5,5	130	4,0
2,5	55	6,5	90	5,0					
3,0	70	8,0	100	6,0					

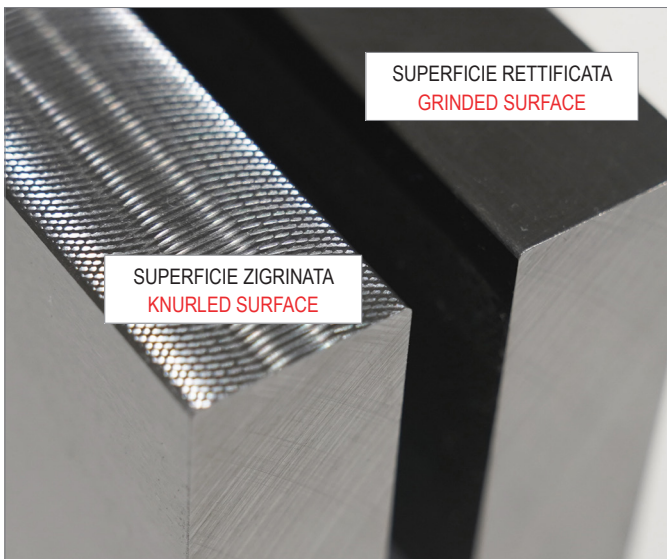

CODE	$\alpha$	R	H	T/Mt	Mt
11.550	24°	0.60	128.00	80	<span style="background-color: red; color: white;"> </span>

415 mm  
835 mm  
800 mm SECTIONED

CODE	$\alpha$	R	H	T/Mt	Mt
11.554	24°	0.60	128.00	80	<span style="background-color: red; color: white;"> </span>

415 mm  
835 mm  
800 mm SECTIONED

CODE	$\alpha$	R	H	T/Mt	Mt
11.560	24°	0.60	128.00	80	<span style="background-color: red; color: white;"> </span>

415 mm  
835 mm  
800 mm SECTIONED

CODE	R	H	T/Mt	Mt
20.550	1.00	80.00	50	<span style="background-color: red; color: white;"> </span>

SUPERFICIE ZIGRINATA  
KNURLED SURFACE

SUPERFICIE RETTIFICATA  
GRINDED SURFACE

415 mm  
835 mm  
800 mm SECTIONED

Max sp 1mm  
Max tk 1mm

CODE	R	H	T/Mt	Mt
20.554	1.00	80.00	50	<span style="background-color: red; color: white;"> </span>

SUPERFICIE ZIGRINATA  
KNURLED SURFACE

SUPERFICIE RETTIFICATA  
GRINDED SURFACE

415 mm  
835 mm  
800 mm SECTIONED

Max sp 1,5mm  
Max tk 1,5mm

CODE	R	H	T/Mt	Mt
20.560	1.00	80.00	50	<span style="background-color: red; color: white;"> </span>

SUPERFICIE ZIGRINATA  
KNURLED SURFACE

SUPERFICIE RETTIFICATA  
GRINDED SURFACE

415 mm  
835 mm  
800 mm SECTIONED

Max sp 2mm  
Max tk 2mm



# TRUMPF STYLE

## PUNZONI

## PUNCHES



## BLUE LINE

**TRUMPF STYLE**



# PUNZONI / PUNCHES TRUMPF STYLE

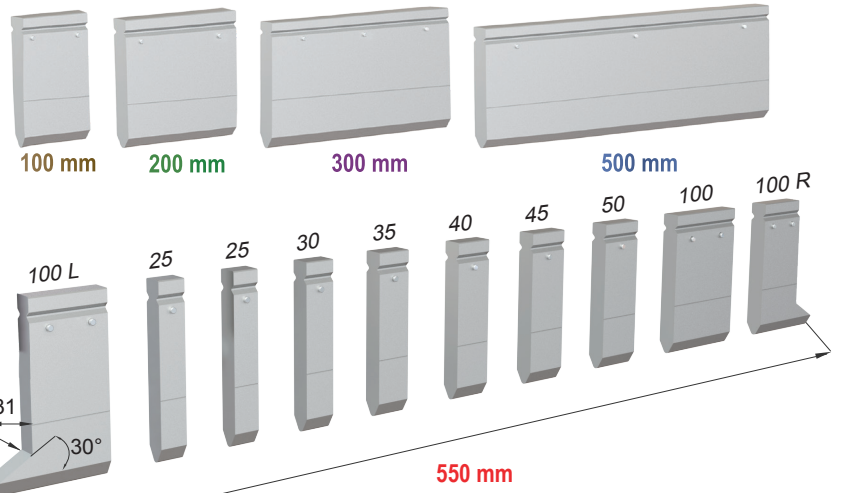
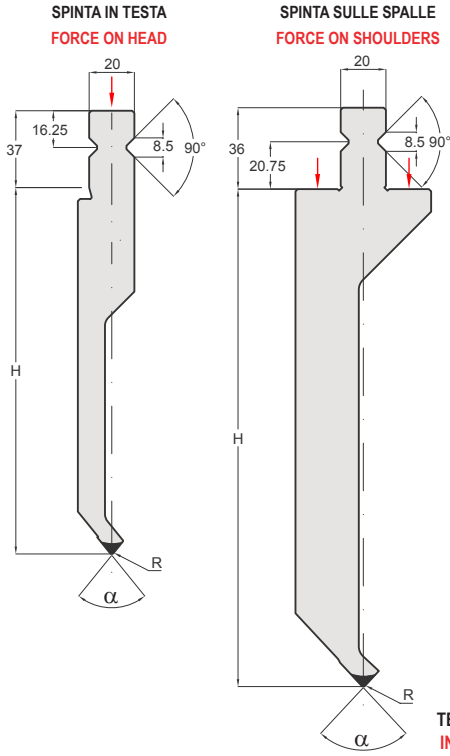

IL CARICO MASSIMO DELLE SCARPETTE CORRISPONDE AL 50% DEL CARICO MASSIMO INDICATO SUL PUNZONE.  
THE MAX LOAD OF THE HORN EXTENSIONS IS 50% OF THE MAX LOAD OF THE PUNCH.

<b>LEGENDA</b>	$\alpha$ = ANGOLO	R = RAGGIO	H = ALTEZZA
<b>LEGEND</b>	$\alpha$ = ANGLE	R = RADIUS	H = HEIGHT

TEMPRA AD INDUZIONE 52-55 HRC  
INDUCTION HARDENED 52-55 HRC

I PUNZONI STANDARD SONO DISPONIBILI A MAGAZZINO NELLE LUNGHEZZE DI: 100 / 200 / 300 mm - 500 mm E FRAZIONATI (550 mm)  
THE PUNCHES ARE AVAILABLE IN THE FOLLOWING STANDARD LENGTHS: 100 / 200 / 300 mm - 500 mm AND SECTIONED (550 mm)

## MONTAGGIO E SMONTAGGIO LATERALE DEGLI UTENSILI SIDE INSTALLATION AND DISINSTALLATION OF TOOLS

SPINTA IN TESTA  
FORCE ON HEAD



SPINTA SULLE SPALLE  
FORCE ON SHOULDERS

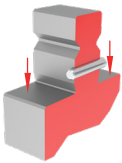

CODE

70.130

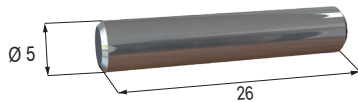

SPARE PARTS

CODE

70.150

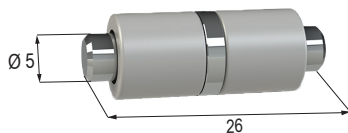

Pag.160

I PUNZONI POSSONO ESSERE FORNITI CON SPINA ROTANTE SU CUSCINETTI - SOLO SU RICHIESTA  
PUNCHES CAN BE SUPPLIED WITH ROLL PIN ON BEARINGS - ONLY ON REQUEST

## MONTAGGIO E SMONTAGGIO FRONTALE DEGLI UTENSILI FRONT INSTALLATION AND DISINSTALLATION OF TOOLS

SPINTA IN TESTA  
FORCE ON HEAD



SPINTA SULLE SPALLE  
FORCE ON SHOULDERS

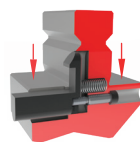

SOLO PER STAMPI FINO ≤ 12,5 KG  
ONLY FOR TOOLS ≤ 12,5 KG

70.714



15.310

70.715



15.320

70.716



15.330 15.335 15.902  
15.904 15.905

70.717

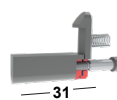

15.450 15.710 15.720  
15.730 15.750

70.718

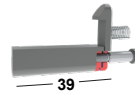

15.370 15.480

70.719

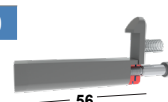

15.380 15.700 15.800

# PUNZONI / PUNCHES TRUMPF STYLE 60° / 80° / 86°

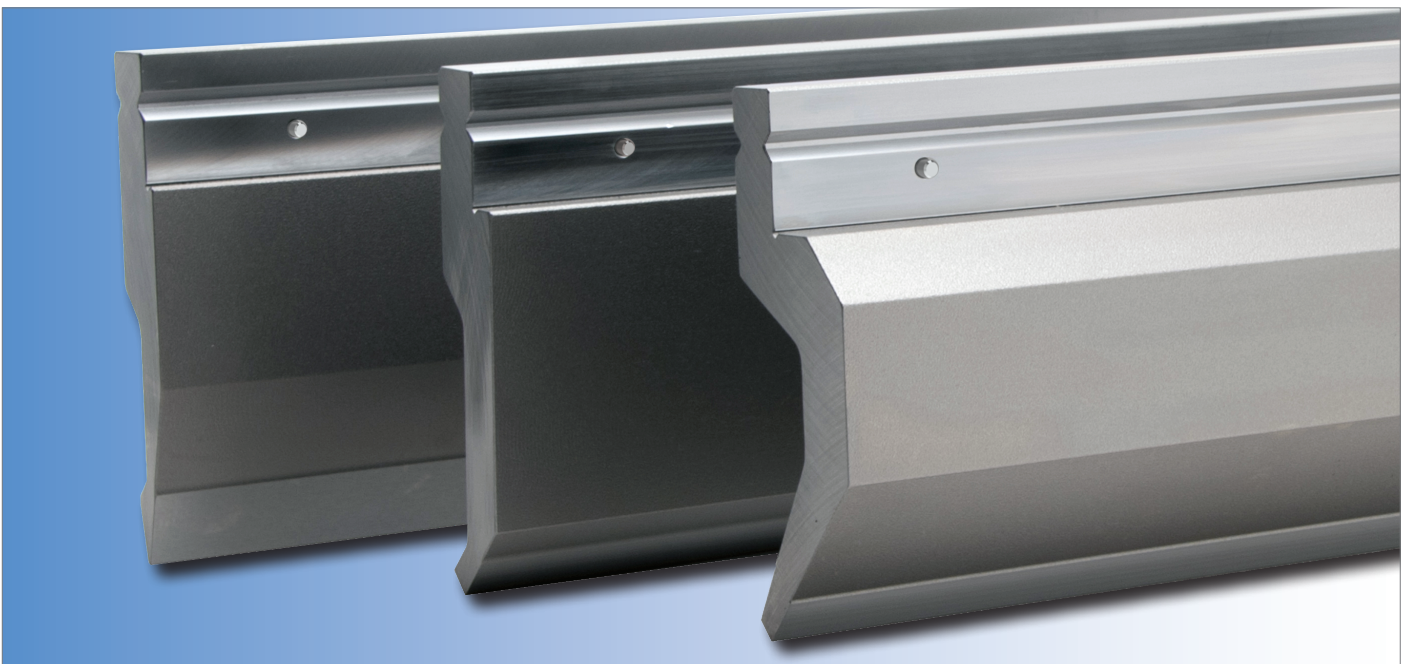
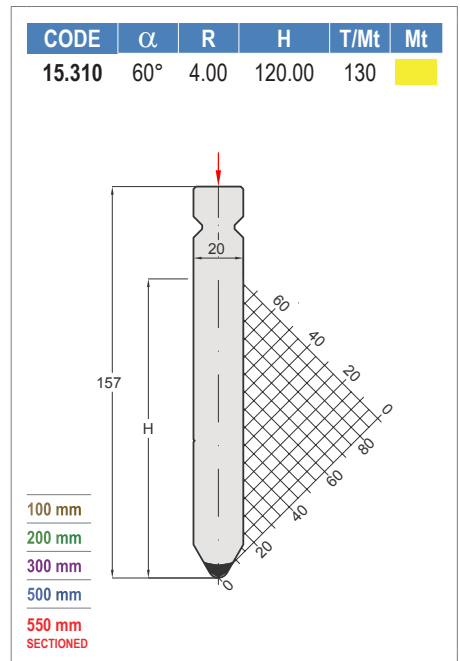
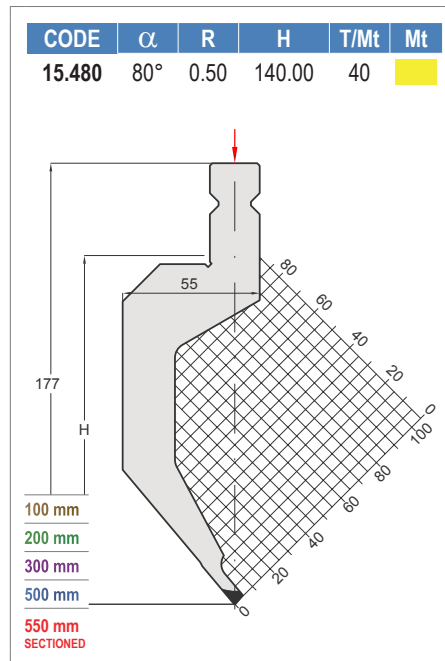
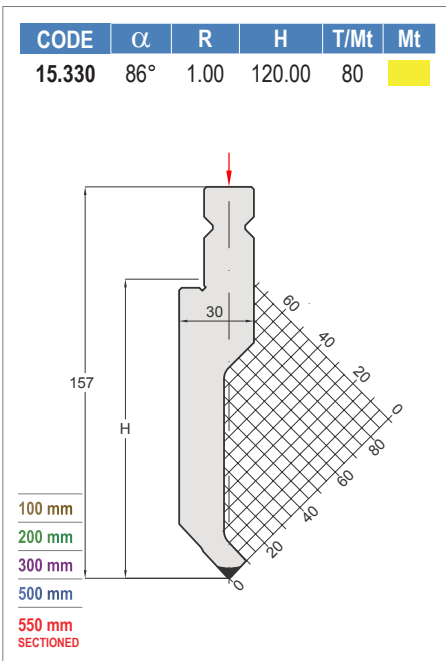
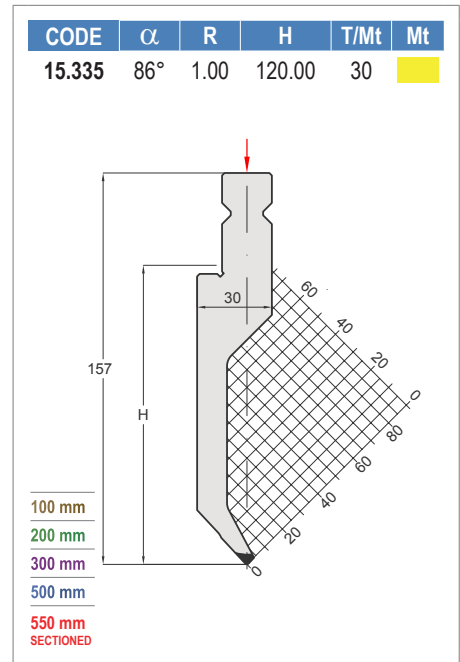
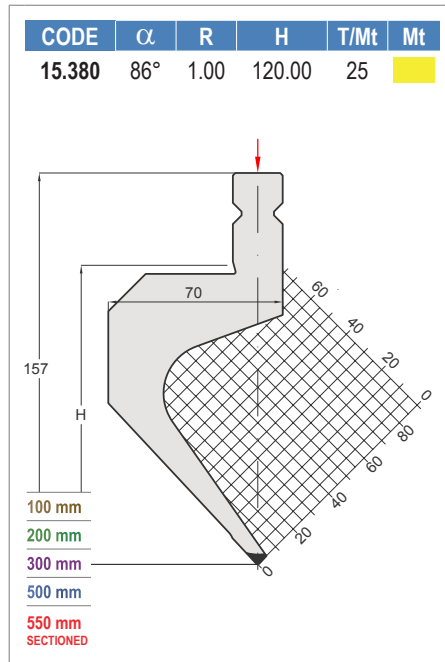
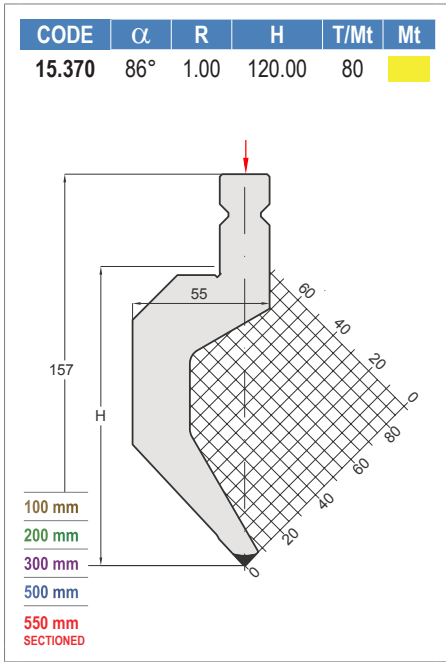

# PUNZONI / PUNCHES TRUMPF STYLE 84° / 86°

CODE	$\alpha$	R	H	T/Mt	Mt
15.700	86°	1.00	220.00	80	<span style="background-color: yellow;"> </span>

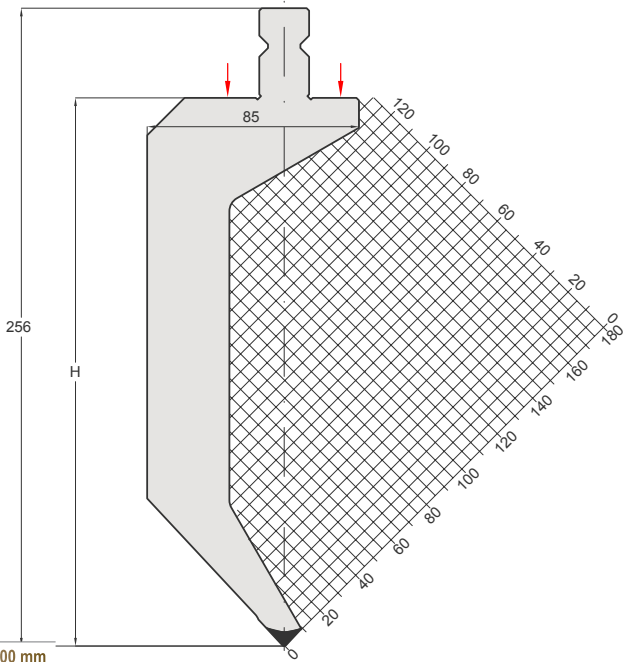

100 mm  
200 mm  
300 mm  
500 mm  
550 mm  
SECTIONED

CODE	$\alpha$	R	H	T/Mt	Mt
15.710	86°	1.00	220.00	80	<span style="background-color: yellow;"> </span>

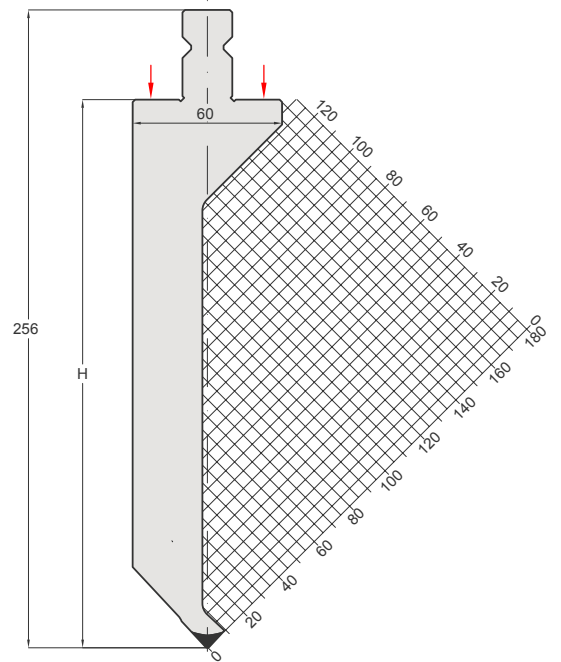

100 mm  
200 mm  
300 mm  
500 mm  
550 mm  
SECTIONED

CODE	$\alpha$	R	H	T/Mt	Mt
15.790	84°	1.00	220.00	60	<span style="background-color: yellow;"> </span>

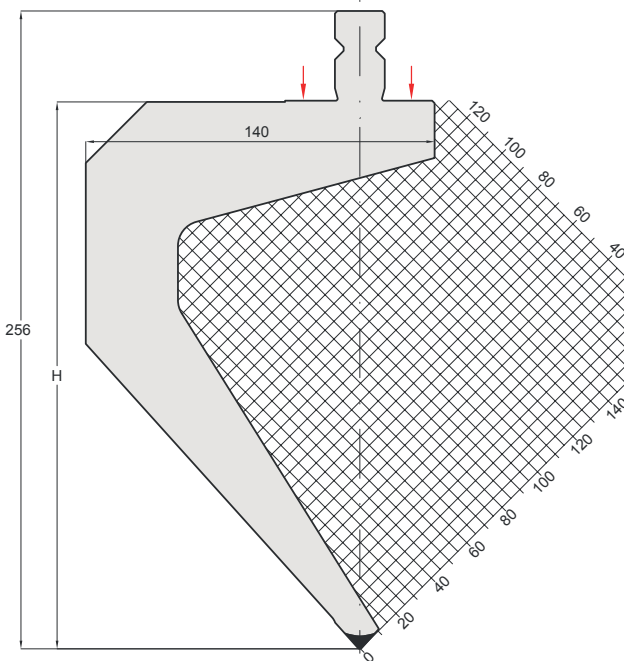

100 mm  
200 mm  
300 mm  
550 mm  
SECTIONED

CODE	$\alpha$	R	H	T/Mt	Mt
15.800	86°	1.00	300.00	80	<span style="background-color: yellow;"> </span>

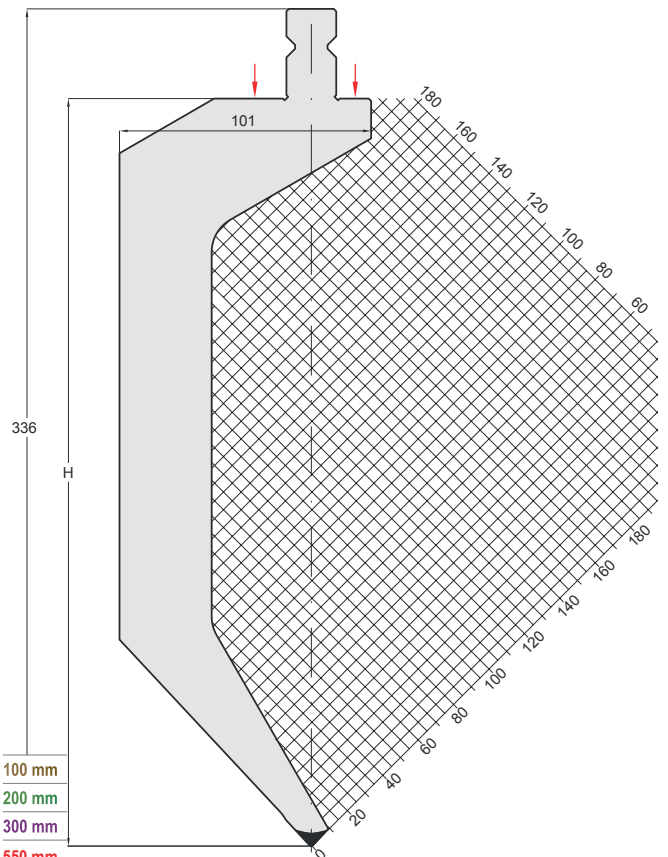

100 mm  
200 mm  
300 mm  
550 mm  
SECTIONED



# PUNZONI / PUNCHES TRUMPF STYLE 28° / 60°

CODE	$\alpha$	R	H	T/Mt	Mt
15.320	28°	1.00	120.00	80	■

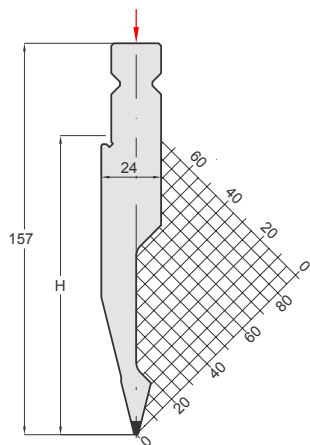

100 mm  
200 mm  
300 mm  
500 mm  
550 mm  
SECTIONED

CODE	$\alpha$	R	H	T/Mt	Mt
15.450	28°	1.00	140.00	40	■

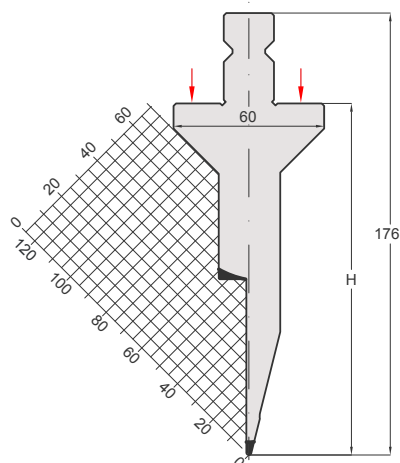

100 mm  
200 mm  
300 mm  
500 mm  
550 mm  
SECTIONED

CODE	$\alpha$	R	H	T/Mt	Mt
15.730	60°	4.00	220.00	130	■

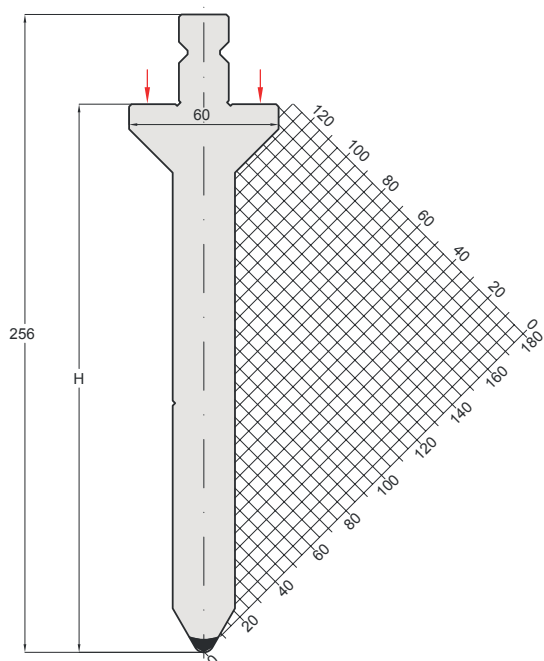

100 mm  
200 mm  
300 mm  
500 mm  
550 mm  
SECTIONED



# PUNZONI / PUNCHES TRUMPF STYLE 28°

CODE	$\alpha$	R	H	T/Mt	Mt
15.720	28°	1.00	220.00	80	<span style="background-color: yellow;"> </span>

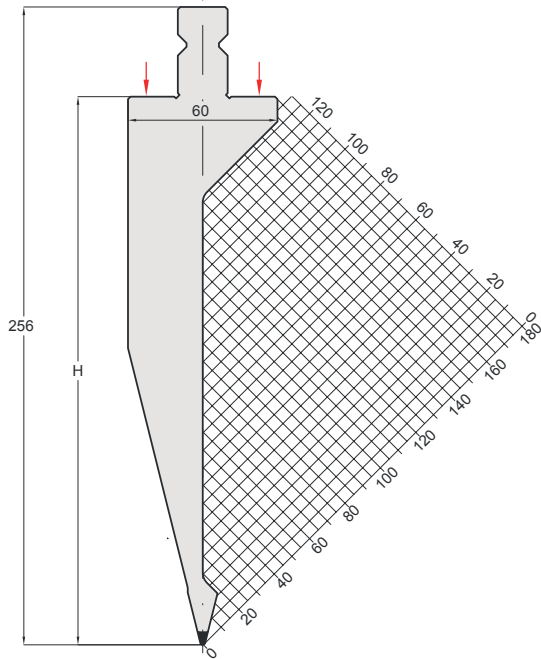

- 100 mm
- 200 mm
- 300 mm
- 500 mm
- 550 mm SECTIONED

CODE	$\alpha$	R	H	T/Mt	Mt
15.750	28°	1.00	240.00	40	<span style="background-color: yellow;"> </span>

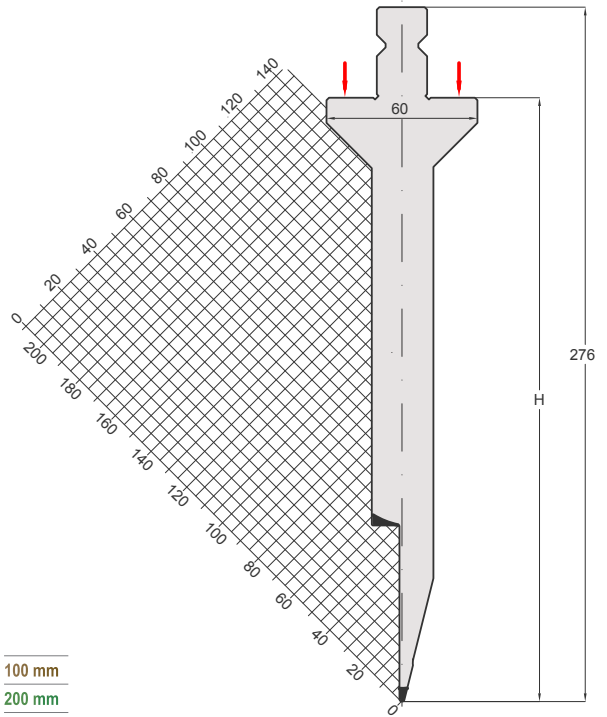

- 100 mm
- 200 mm
- 300 mm
- 500 mm
- 550 mm SECTIONED

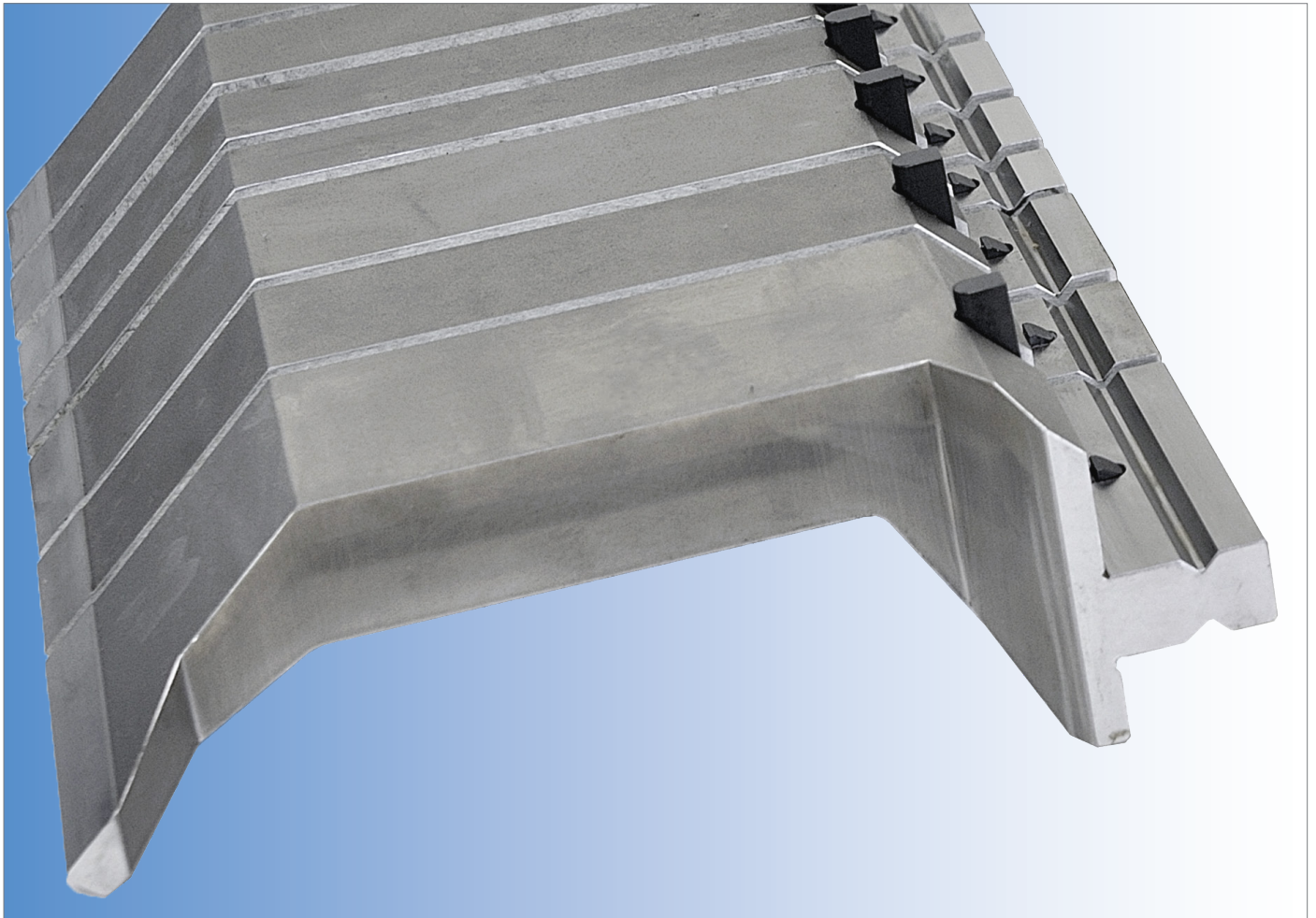

# TRUMPF STYLE

## MATRICI

## DIES

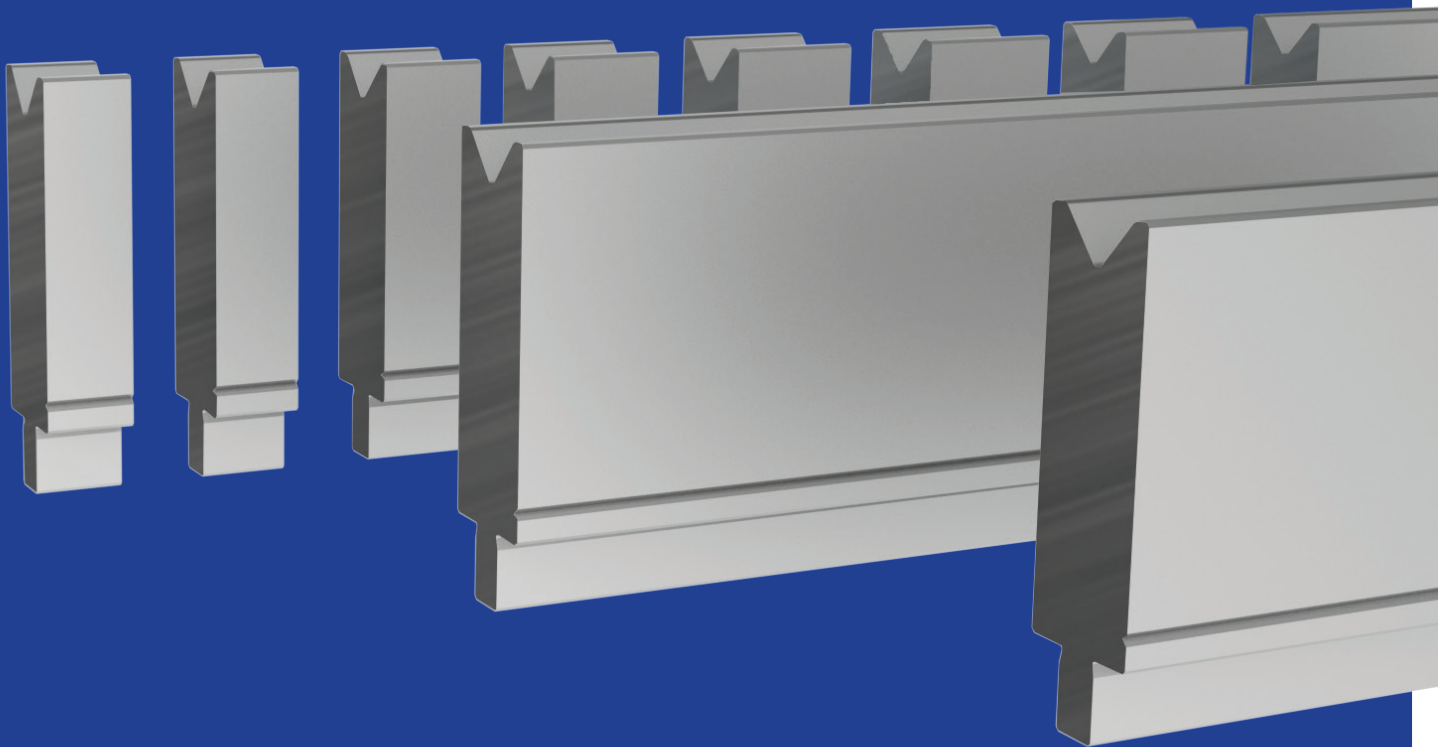

## BLUE LINE

**TRUMPF STYLE**



# MATRICI / DIES TRUMPF STYLE

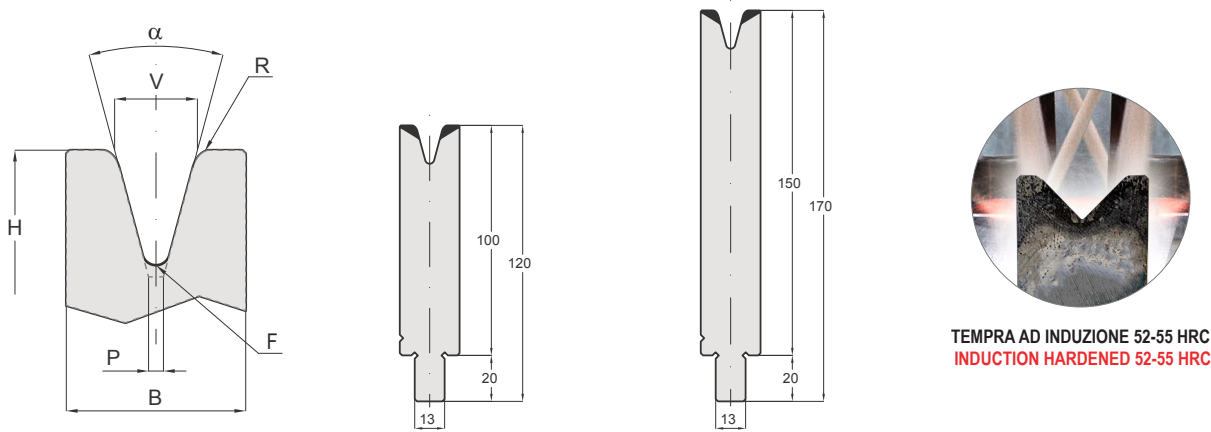

100 mm | 200 mm | 300 mm | 500 mm | 550 mm SECTIONED

LE MATRICI STANDARD SONO DISPONIBILI A MAGAZZINO NELLE LUNGHEZZE DI: 100 / 200 / 300 mm - 500 mm E FRAZIONATI (550 mm)  
THE DIES ARE AVAILABLE IN THE FOLLOWING STANDARD LENGTHS: 100 / 200 / 300 mm - 500 mm AND SECTIONED (550 mm)

<b>LEGENDA</b>	$\alpha$ = ANGOLO	V = AMPIEZZA CAVA	R = RAGGIO	H = ALTEZZA	F = FONDO MATRICE	P = PIANO	B = BASE
<b>LEGEND</b>	$\alpha$ = ANGLE	V = DIE OPENING	R = RADIUS	H = HEIGHT	F = BOTTOM DIE	P = FLAT	B = WIDTH

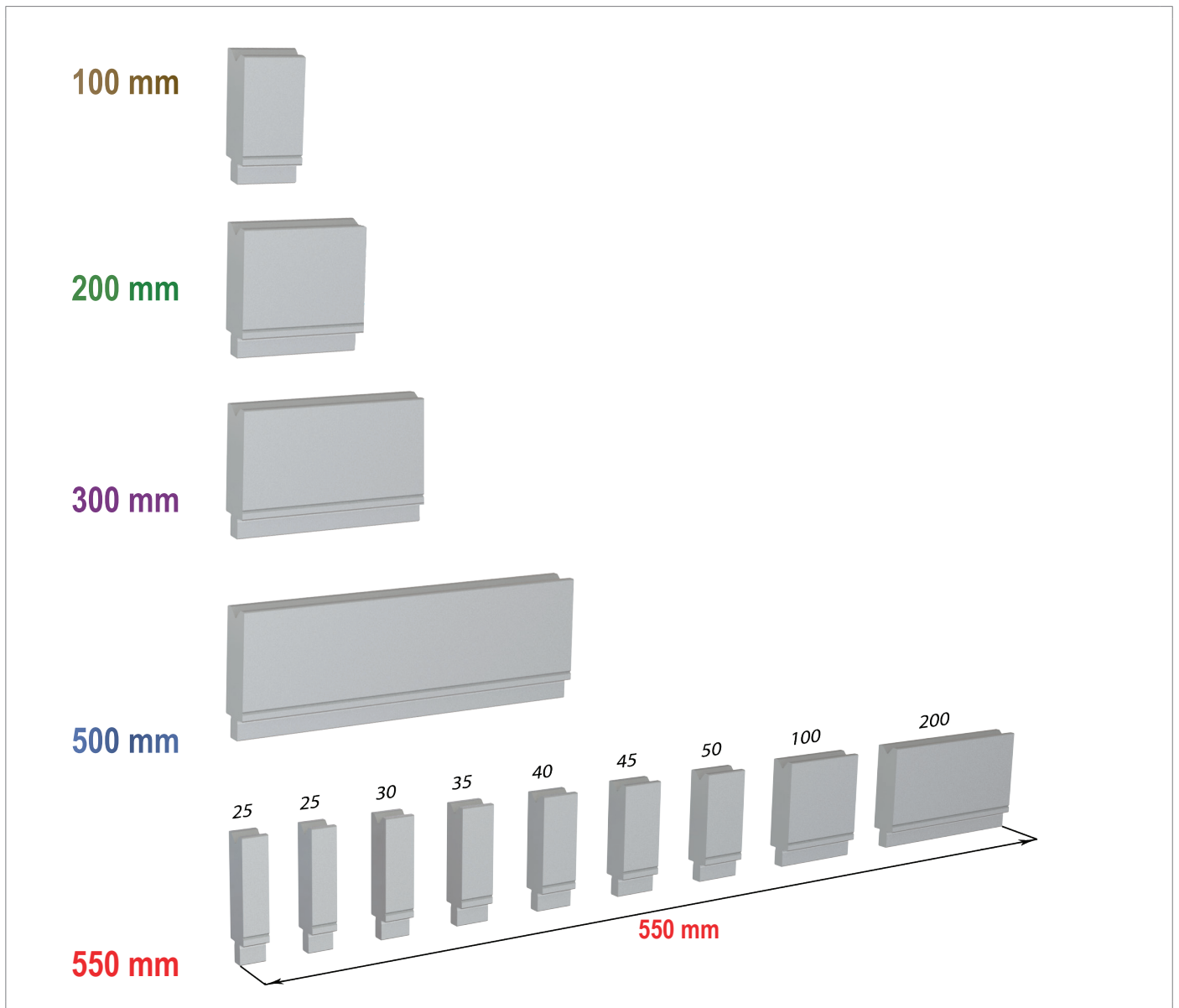

# MATRICI / DIES TRUMPF STYLE H=100 / 120

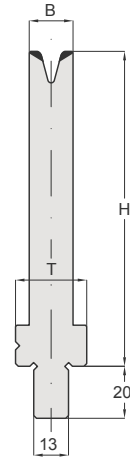
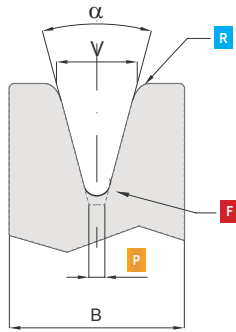

100 mm | 200 mm | 300 mm | 500 mm | 550 mm SECTIONED

LE MATRICI STANDARD SONO DISPONIBILI A MAGAZZINO NELLE LUNGHEZZE DI: 100 / 200 / 300 mm - 500 mm E FRAZIONATI (550 mm)  
 THE DIES ARE AVAILABLE IN THE FOLLOWING STANDARD LENGTHS: 100 / 200 / 300 mm - 500 mm AND SECTIONED (550 mm)

LEGENDA	$\alpha$ = ANGOLO	V = AMPIEZZA CAVA	R = RAGGIO	H = ALTEZZA	B = STELO	T = BASE	F = FONDO MATRICE	P = PIANO
LEGEND	$\alpha$ = ANGLE	V = DIE OPENING	R = RADIUS	H = HEIGHT	B = BODY	T = BASE	F = BOTTOM DIE	P = FLAT

CODE	$\alpha$	V	R	H	B	T	F	T/mt	Mt	CODE	$\alpha$	V	R	H	B	T	F	T/mt	Mt
25.100	86°	4	0.60	100	8	20	R0.6	25	■	25.111	80°	60	5.00	100	75	75	R5.0	150	■
25.101	86°	6	0.60	100	20	20	R0.6	100	■	25.112	80°	70	5.00	100	85	85	R5.0	150	■
25.102	86°	8	0.80	100	20	20	R0.8	100	■	25.113	80°	80	5.00	100	100	100	R5.0	150	■
25.103	86°	10	1.00	100	20	20	R1.0	100	■	25.114	80°	90	8.00	120	110	110	R5.0	150	■
25.104	86°	12	1.00	100	25	25	R1.0	100	■	25.115	80°	100	8.00	120	120	120	R5.0	150	■
25.105	86°	16	1.60	100	30	30	R1.6	100	■	25.116	60°	120	8.00	120	145	145	P38	160	■
25.106	86°	20	2.00	100	30	30	R2.0	100	■	25.400	30°	4	0.60	100	15	20	R0.6	20	■
25.107	86°	24	2.50	100	35	35	R2.5	100	■	25.401	30°	6	0.60	100	20	20	R0.6	40	■
25.108	86°	30	3.00	100	45	45	R3.0	100	■	25.402	30°	8	1.00	100	20	20	R1.0	40	■
25.109	86°	40	3.00	100	55	55	R3.0	120	■	25.403	30°	10	1.00	100	20	20	R1.0	40	■
25.110	86°	50	3.00	100	75	75	R5.0	150	■	25.404	30°	12	1.00	100	25	25	R1.0	40	■
25.350	86°	5	0.60	100	8	20	R0.6	25	■	25.405	30°	16	1.60	100	30	30	R1.6	50	■
25.200	84°	4	0.60	100	8	20	R0.6	25	■	25.406	30°	20	2.00	100	35	35	R2.0	60	■
25.201	84°	6	0.60	100	20	20	R0.6	100	■	25.407	30°	24	2.50	100	40	40	R2.5	65	■
25.202	84°	8	0.80	100	20	20	R0.8	100	■	25.408	30°	30	3.00	100	55	55	R3.0	90	■
25.203	84°	10	1.00	100	20	20	R1.0	100	■	25.409	30°	40	5.00	100	60	60	R5.0	90	■
25.204	84°	12	1.00	100	25	25	R1.0	100	■	25.410	30°	50	5.00	100	75	75	P17	100	■
25.205	84°	16	1.60	100	30	30	R1.6	100	■	25.421	30°	6	3.00	100	20	20	R0.6	40	■
25.206	84°	20	2.00	100	30	30	R2.0	100	■	25.422	30°	8	3.00	100	20	20	R1.0	40	■
25.300	84°	5	0.60	100	8	20	R0.6	25	■	25.423	30°	10	3.00	100	20	20	R1.0	40	■
25.301	84°	6	0.60	100	10	20	R0.6	25	■	25.424	30°	12	3.00	100	25	25	R1.0	40	■
25.302	84°	8	0.80	100	12	20	R0.8	35	■	25.425	30°	16	3.00	100	30	30	R1.6	50	■
25.303	84°	10	1.00	100	14	20	R1.0	40	■	25.500	30°	5	0.60	100	15	20	R0.6	15	■
25.304	84°	12	1.00	100	16	20	R1.0	40	■	25.501	30°	6	0.60	100	16	20	R0.6	17	■
25.207	80°	24	2.50	100	35	35	R2.5	100	■	25.502	30°	8	1.00	100	17	20	R1.0	20	■
25.208	80°	30	5.00	100	45	45	R3.0	100	■	25.503	30°	10	1.00	100	18	20	R1.0	20	■
25.209	80°	40	5.00	100	55	55	R3.0	120	■	25.504	30°	12	1.00	100	21.5	25	R1.0	25	■
25.210	80°	50	5.00	100	65	65	R5.0	150	■										

# MATRICI / DIES TRUMPF STYLE H=150

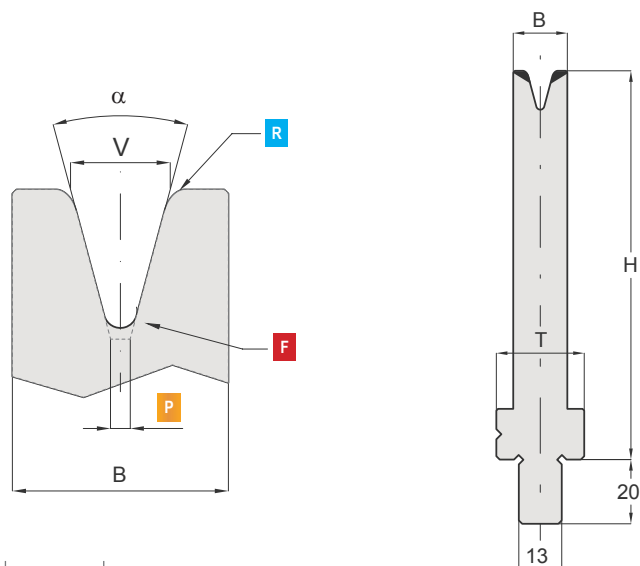

100 mm | 200 mm | 300 mm | 500 mm | 550 mm SECTIONED

LE MATRICI STANDARD SONO DISPONIBILI A MAGAZZINO NELLE LUNGHEZZE DI: 100 / 200 / 300 mm - 500 mm E FRAZIONATI (550 mm)  
 THE DIES ARE AVAILABLE IN THE FOLLOWING STANDARD LENGTHS: 100 / 200 / 300 mm - 500 mm AND SECTIONED (550 mm)

<b>LEGENDA</b>	α = ANGOLO	V = AMPIEZZA CAVA	R = RAGGIO	H = ALTEZZA	B = STELO	T = BASE	F = FONDO MATRICE	P = PIANO
<b>LEGEND</b>	α = ANGLE	V = DIE OPENING	R = RADIUS	H = HEIGHT	B = BODY	T = BASE	F = BOTTOM DIE	P = FLAT

CODE	α	V	R	H	B	T	F	T/mt	Mt
25.601	86°	6	0.60	150	20	20	R0.6	100	■
25.602	86°	8	0.80	150	20	20	R0.8	100	■
25.603	86°	10	1.00	150	20	20	R1.0	100	■
25.604	86°	12	1.00	150	25	25	R1.0	100	■
25.605	86°	16	1.60	150	30	30	R1.6	100	■
25.606	86°	20	2.00	150	30	30	R2.0	100	■
25.607	86°	24	2.50	150	35	35	R2.5	100	■
25.621	84°	6	0.60	150	20	20	R0.6	100	■
25.622	84°	8	0.80	150	20	20	R0.8	100	■
25.623	84°	10	1.00	150	20	20	R1.0	100	■
25.624	84°	12	1.00	150	25	25	R1.0	100	■
25.625	84°	16	1.60	150	30	30	R1.6	100	■
25.626	84°	20	2.00	150	30	30	R2.0	100	■
25.627	80°	24	2.50	150	35	35	R2.5	100	■
25.628	80°	30	5.00	150	45	45	R3.0	100	■
25.629	80°	40	5.00	150	55	55	R3.0	100	■
25.630	80°	50	5.00	150	65	65	R5.0	100	■
25.901	30°	6	0.60	150	20	20	R0.6	40	■
25.902	30°	8	1.00	150	20	20	R1.0	40	■
25.903	30°	10	1.00	150	20	20	R1.0	40	■
25.904	30°	12	1.00	150	25	25	R1.0	40	■
25.905	30°	16	1.60	150	30	30	R1.6	50	■
25.906	30°	20	2.00	150	35	35	R2.0	60	■
25.907	30°	24	2.50	150	40	40	R2.5	65	■
25.908	30°	30	3.00	150	55	55	R3.0	90	■
25.909	30°	40	5.00	150	60	60	R5.0	90	■

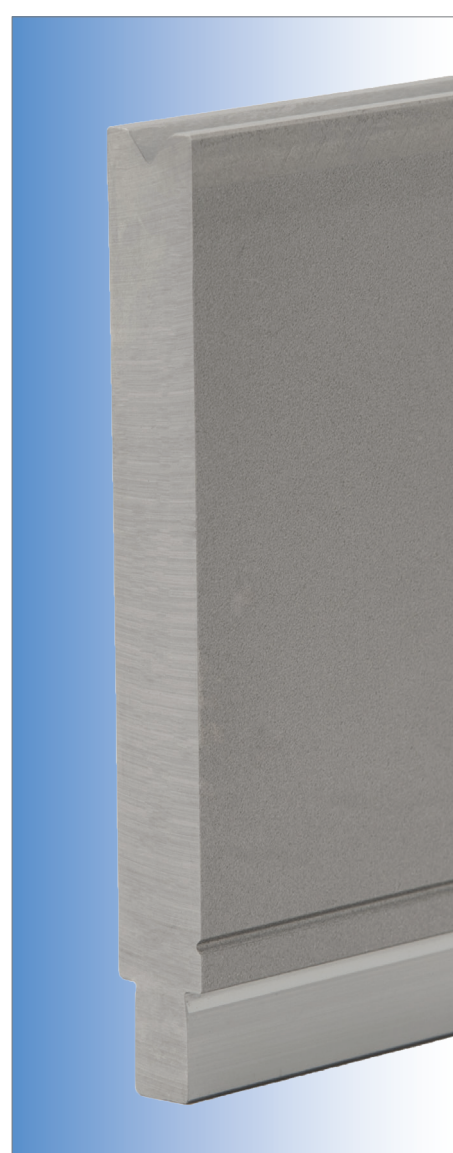

# TRUMPF STYLE

PIEGASCHIACCIA

HEMMING TOOLS

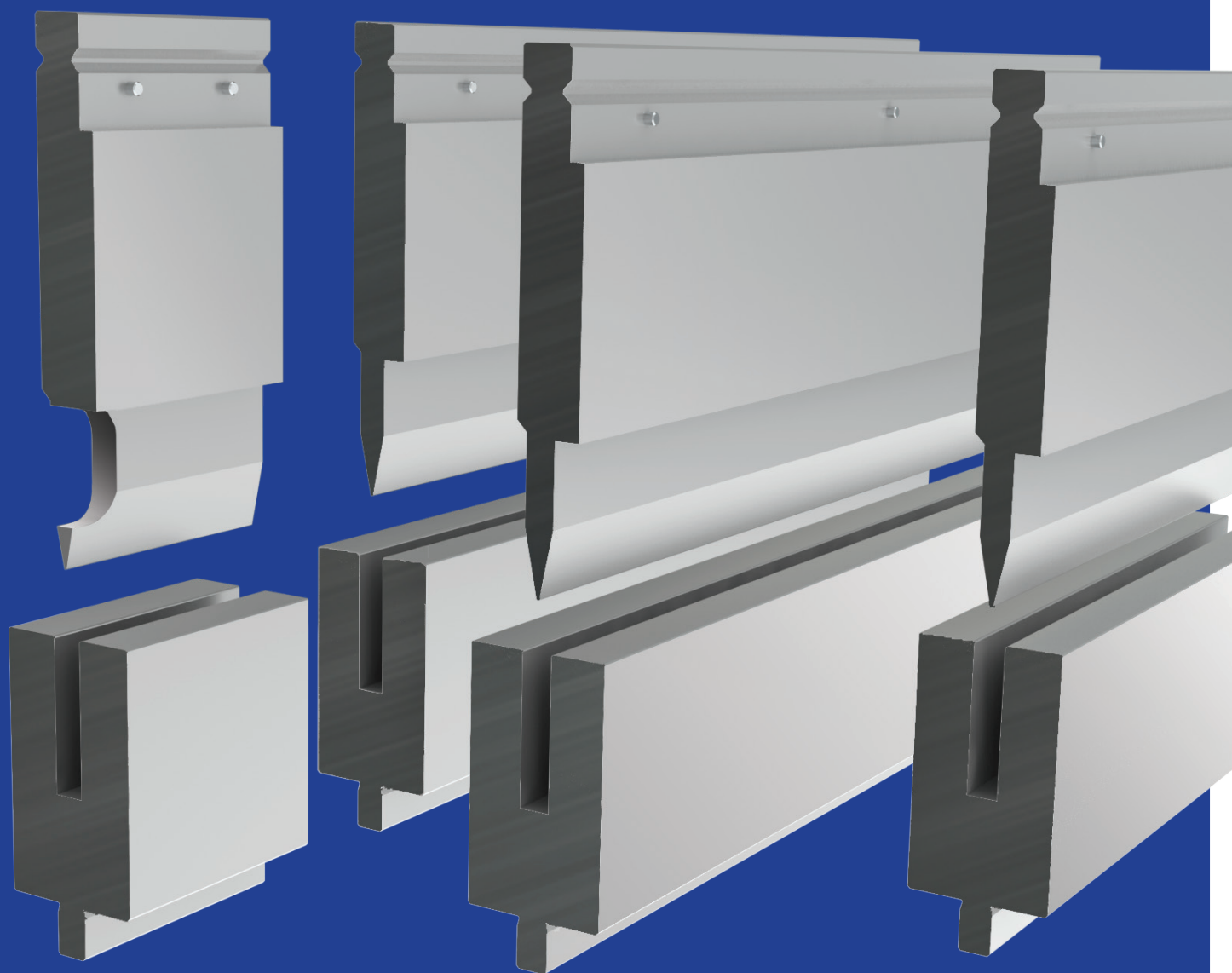

## BLUE LINE

TRUMPF STYLE



# PIEGASCHIACCIA / HEMMING TOOLS TRUMPF STYLE

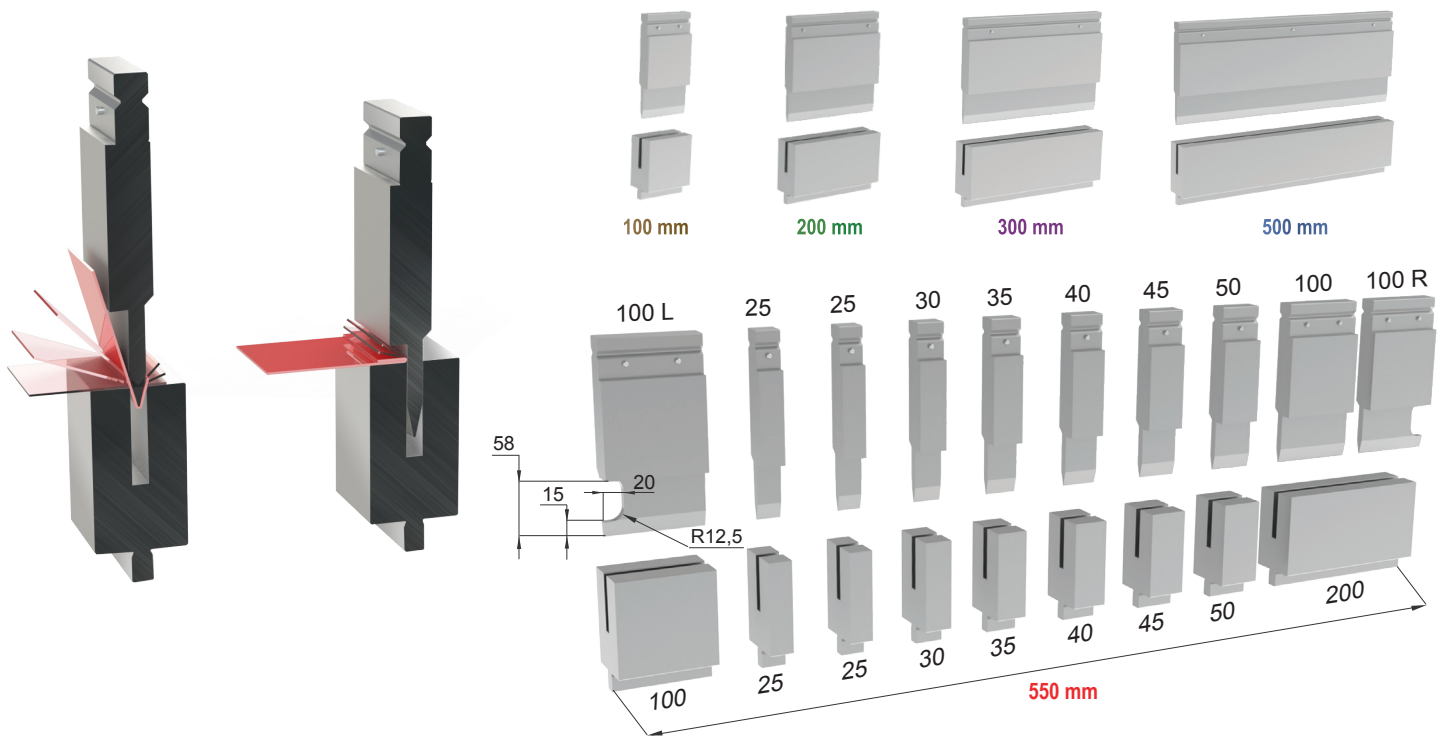

100 mm | 200 mm | 300 mm | 500 mm | 550 mm SECTIONED

IL CARICO MASSIMO DELLE SCARPETTE CORRISPONDE AL 50% DEL CARICO MASSIMO INDICATO SUL PUNZONE.  
 THE MAX LOAD OF THE HORN EXTENSIONS IS 50% OF THE MAX LOAD OF THE PUNCH.

MATERIAL ACC.R ~ 40 Kg/MM <sup>2</sup>					MATERIAL ACC.R ~ 70 Kg/MM <sup>2</sup>						
S		T		2S		S		2S		S	
MATERIAL ACC.R ~ 40 Kg/MM <sup>2</sup>					MATERIAL ACC.R ~ 70 Kg/MM <sup>2</sup>						
S (mm)	(t/m)	T (mm)	(t/m)	2S(mm)	S (mm)	(t/m)	T (mm)	(t/m)	2S(mm)	S (mm)	(t/m)
0,6	9	3	23	1,2	0,6	15	3	35	1,2	0,6	15
0,8	12	3	32	1,6	0,8	20	3	50	1,6	0,8	20
1,0	15	3,5	40	2,0	1,0	25	3,5	60	2,0	1,0	25
1,25	17	3,5	50	2,5	1,25	26	3,5	80	2,5	1,25	26
1,5	22	4,6	63	3,0	1,5	38	4,6	95	3,0	1,5	38
2,0	30	5,5	80	4,0	2,0	50	5,5	130	4,0	2,0	50
2,5	55	6,5	90	5,0							
3,0	70	8,0	100	6,0							

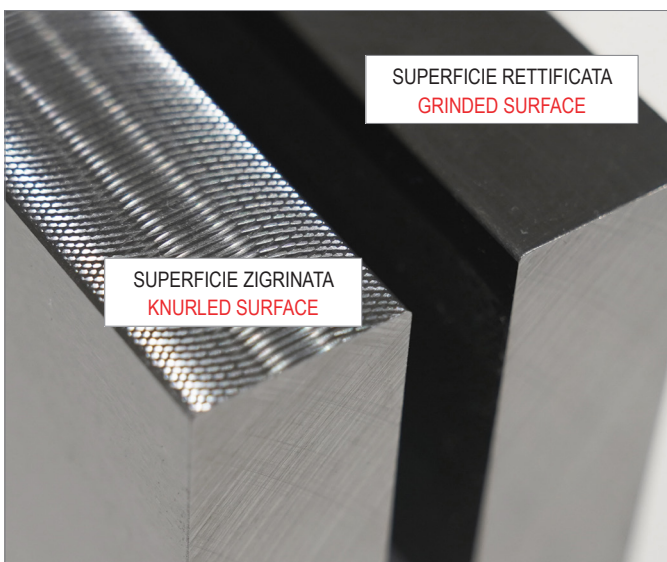



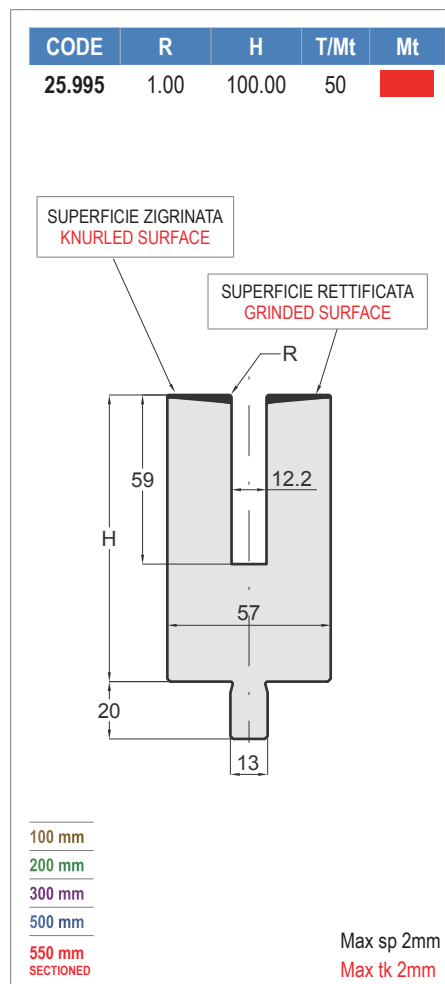
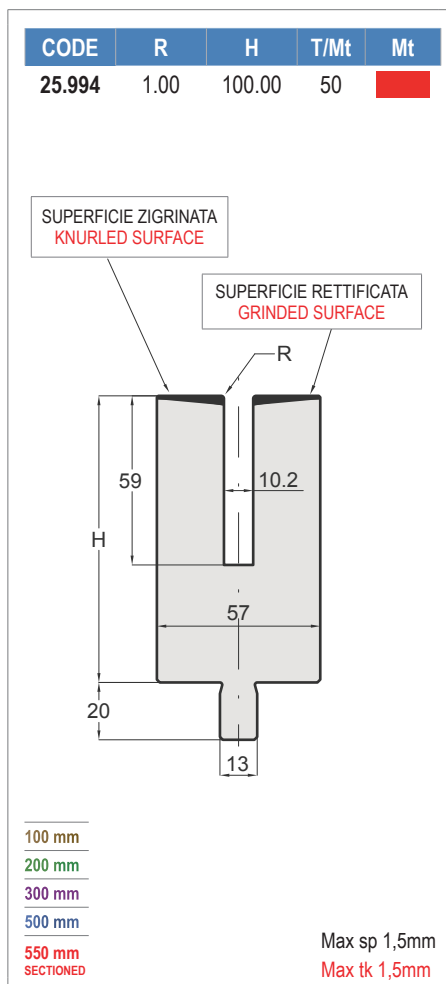
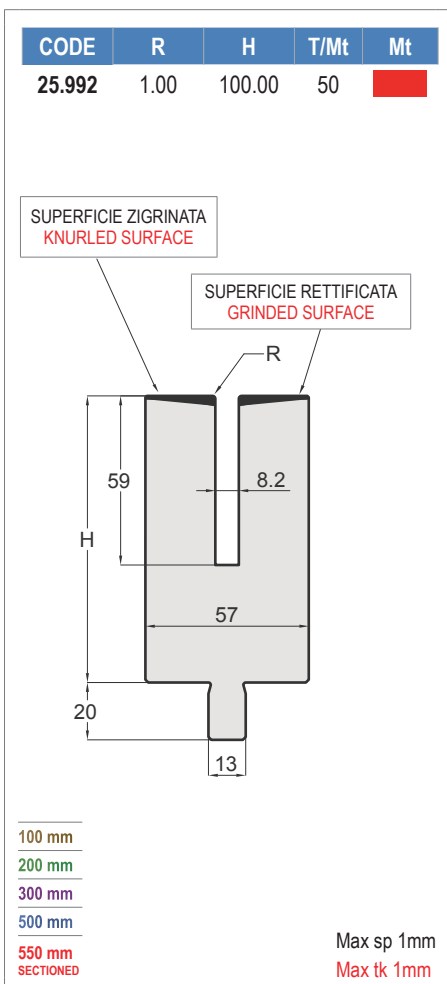
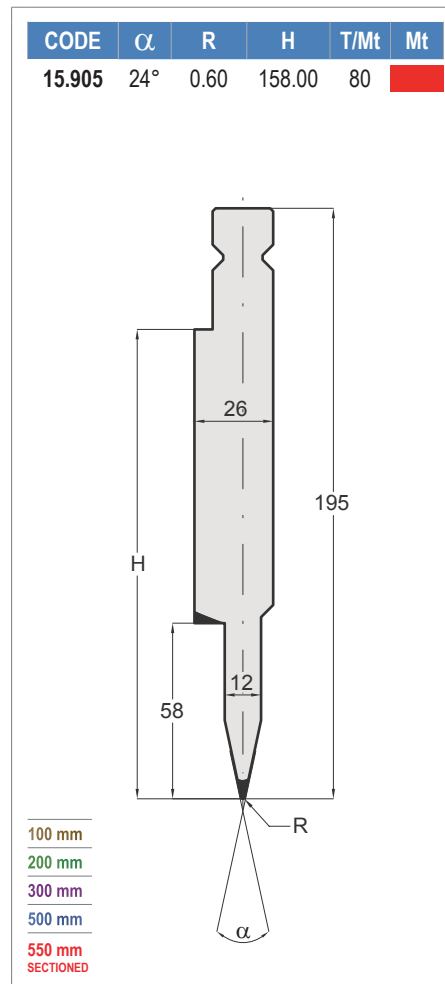
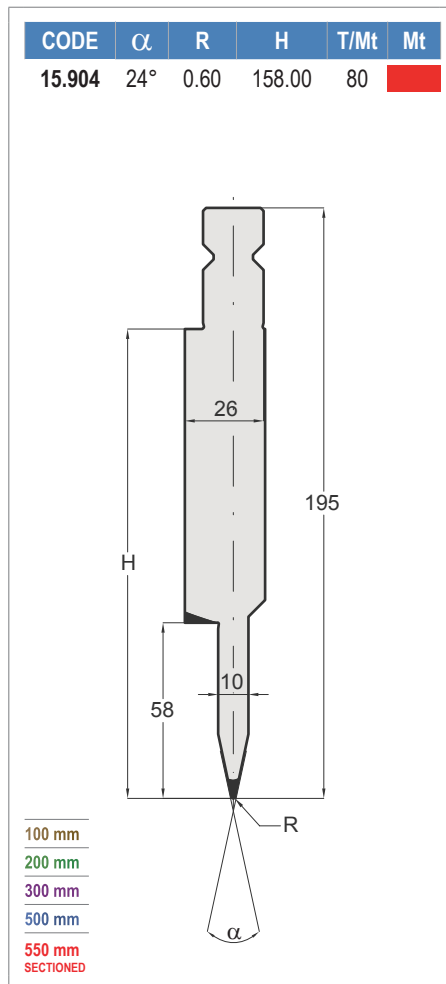
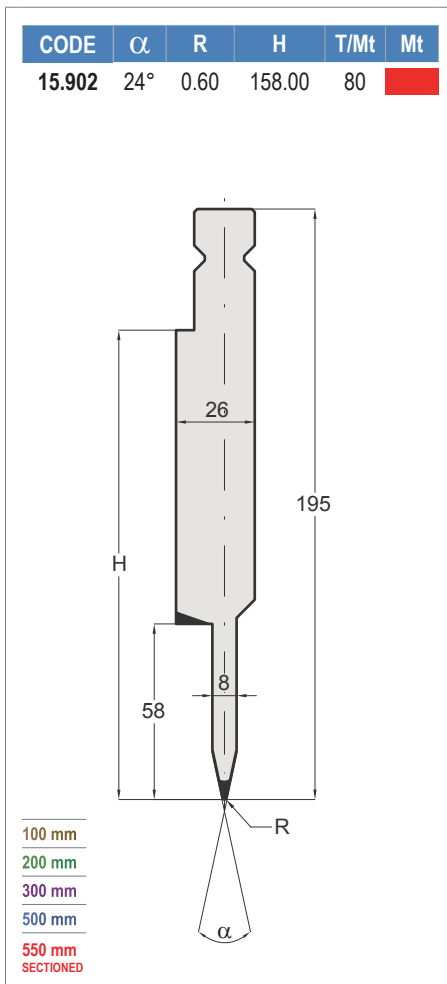

CODE	H	T/Mt	Mt
60.120	100.00	120	

100 mm  
200 mm  
300 mm  
500 mm  
550 mm SECTIONED

**CODE**  
**70.800**

CODICE FORATURA MATRICI PER APPLICARE L'INSERTO SCHIACCIATORE 60.120

CODE OF DRILL HOLES IN THE DIE FOR USE OF SCREWABLE FLATTENING DIE 60.120

100 mm  
200 mm  
300 mm  
500 mm  
550 mm SECTIONED

CODE	H	T/Mt	Mt
60.130	150.00	120	

100 mm  
200 mm  
300 mm  
500 mm  
550 mm SECTIONED

**CODE**  
**70.810**

CODICE FORATURA MATRICI PER APPLICARE L'INSERTO SCHIACCIATORE 60.130

CODE OF DRILL HOLES IN THE DIE FOR USE OF SCREWABLE FLATTENING DIE 60.130

100 mm  
200 mm  
300 mm  
500 mm  
550 mm SECTIONED

# WILA STYLE

## PUNZONI

## PUNCHES

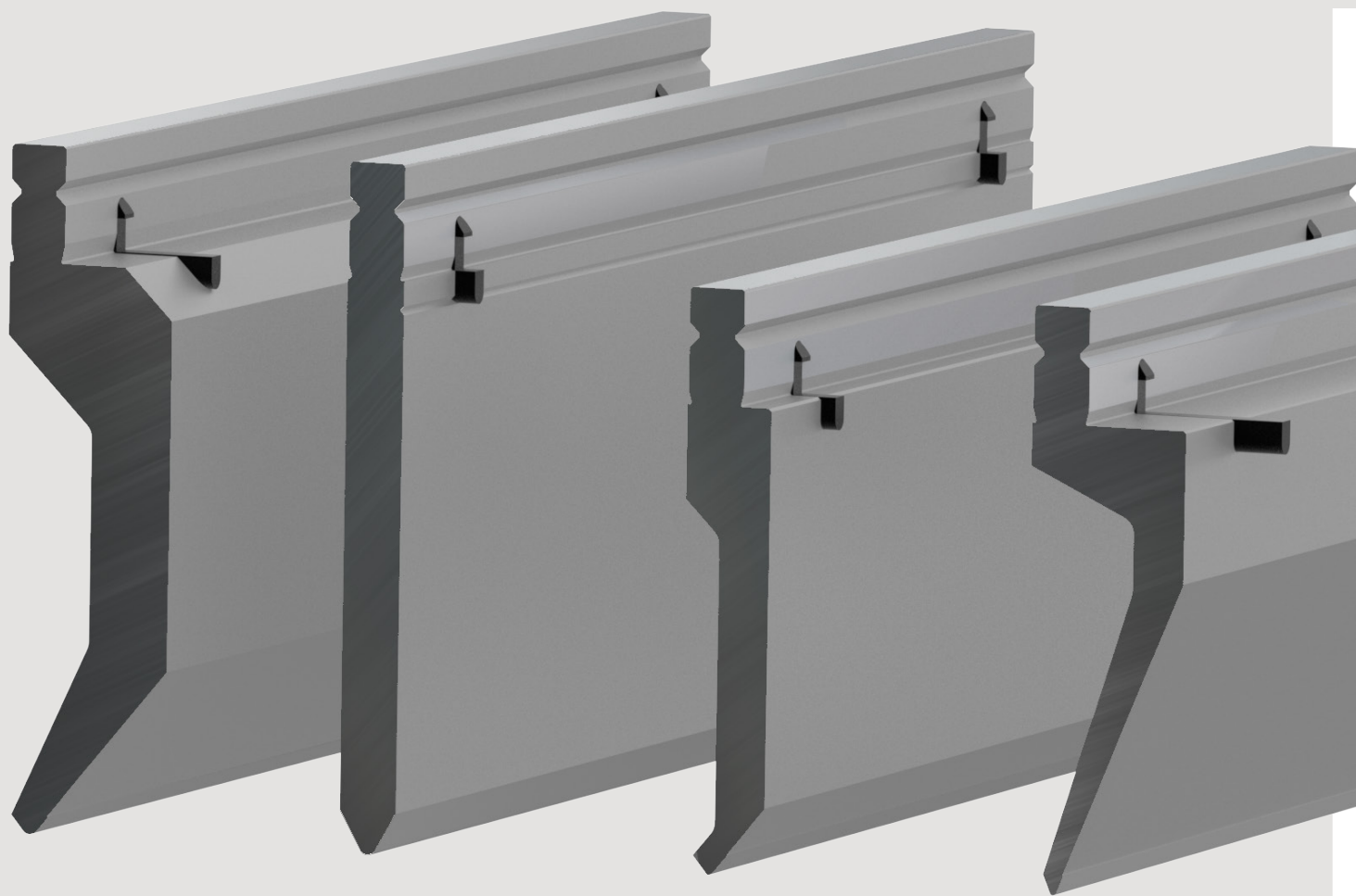

# PLATINUM LINE

WILA STYLE



# PUNZONI / PUNCHES WILA STYLE

**SPINTA IN TESTA**  
**FORCE ON HEAD**

**SPINTA SULLE SPALLE**  
**FORCE ON SHOULDERS**

100 mm    200 mm    300 mm    515 mm

25    25    30    35    40    45    50    100    100 R

550 mm

41/47    100 L    30°    R=8    31    30°    12

IL CARICO MASSIMO DELLE SCARPETTE CORRISPONDE AL 50% DEL CARICO MASSIMO INDICATO SUL PUNZONE.  
THE MAX LOAD OF THE HORN EXTENSIONS IS 50% OF THE MAX LOAD OF THE PUNCH.

TEMPRA AD INDUZIONE 52-55 HRC  
INDUCTION HARDENED 52-55 HRC

<b>LEGGENDA</b>	$\alpha$ = ANGOLO	R = RAGGIO	H = ALTEZZA
<b>LEGEND</b>	$\alpha$ = ANGLE	R = RADIUS	H = HEIGHT

I PUNZONI STANDARD SONO DISPONIBILI A MAGAZZINO NELLE LUNGHEZZE DI: 100 / 200 / 300 mm - 515 mm E FRAZIONATI (550 mm)  
THE PUNCHES ARE AVAILABLE IN THE FOLLOWING STANDARD LENGTHS: 100 / 200 / 300 mm - 515 mm AND SECTIONED (550 mm)

**MONTAGGIO E SMONTAGGIO LATERALE DEGLI UTENSILI**  
**SIDE INSTALLATION AND DISINSTALLATION OF TOOLS**

**SPINTA IN TESTA**  
**FORCE ON HEAD**

**SPINTA SULLE SPALLE**  
**FORCE ON SHOULDERS**

**WEIGHT LIMIT > 12.5 Kg**

**CODE**  
70.130

$\varnothing 5$     26

**SPARE PARTS**

---

**CODE**  
70.150

$\varnothing 5$     26

Pag.160

I PUNZONI POSSONO ESSERE FORNITI CON SPINA ROTANTE SU CUSCINETTI - SOLO SU RICHIESTA  
PUNCHES CAN BE SUPPLIED WITH ROLL PIN ON BEARINGS - ONLY ON REQUEST

**MONTAGGIO E SMONTAGGIO FRONTALE DEGLI UTENSILI**  
**FRONT INSTALLATION AND DISINSTALLATION OF TOOLS**

**SPINTA IN TESTA**  
**FORCE ON HEAD**

**SPINTA SULLE SPALLE**  
**FORCE ON SHOULDERS**

**WEIGHT LIMIT ≤ 12.5 Kg**

SOLO PER STAMPI FINO ≤ 12,5 KG  
ONLY FOR TOOLS ≤ 12,5 KG

<b>70.714</b>		19.024	19.034	
<b>70.715</b>		19.021	19.031	19.221
		19.224	19.231	
<b>70.716</b>		19.022	19.032	
<b>70.718</b>		19.023	19.033	19.225    19.233
		19.235		
<b>70.719</b>		19.226		

# PUNZONI / PUNCHES WILA STYLE 28° / 45° / 60° / 80° / 86° H=163 - 200

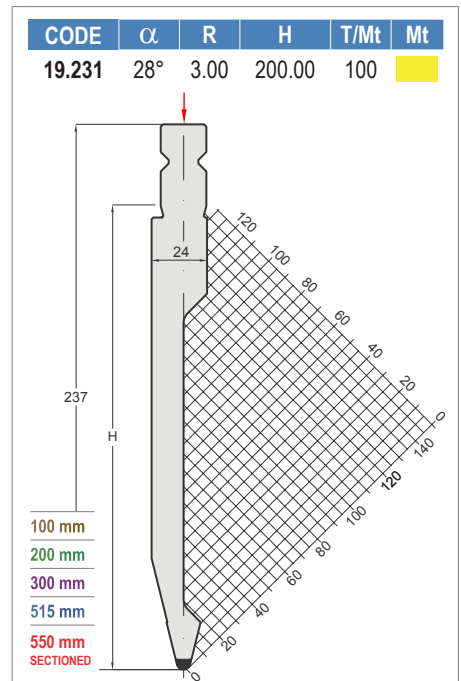
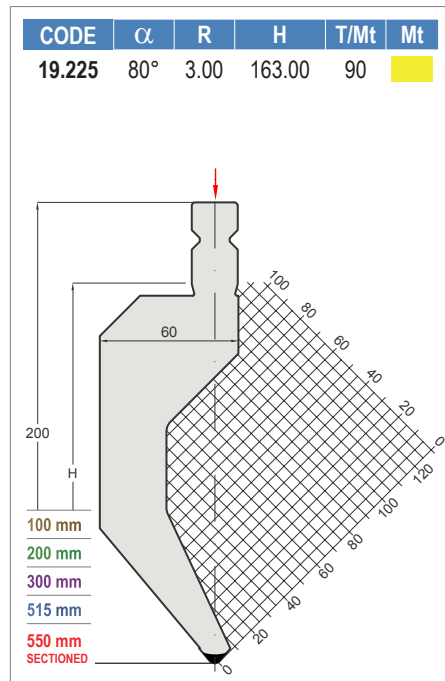
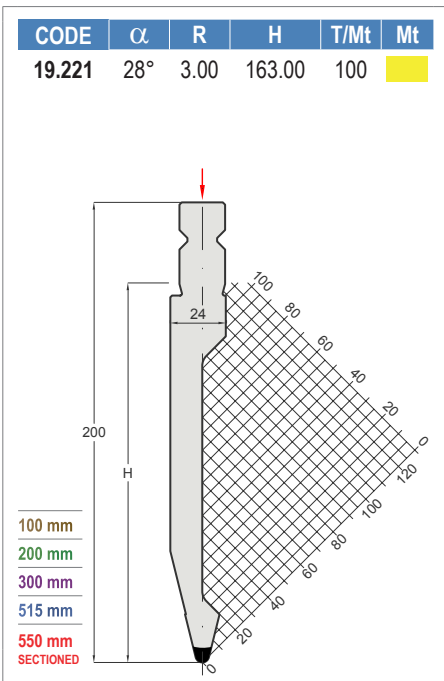
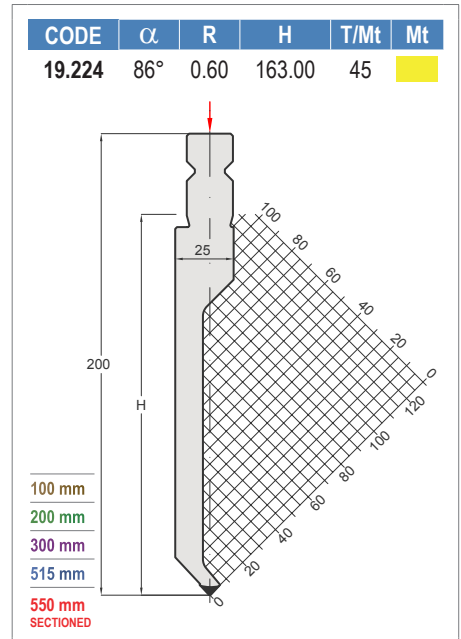
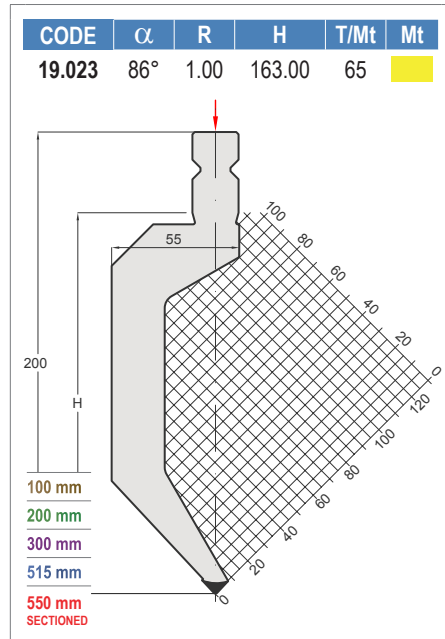
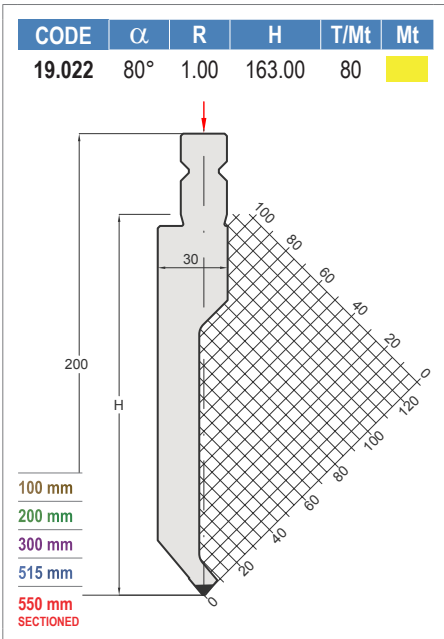
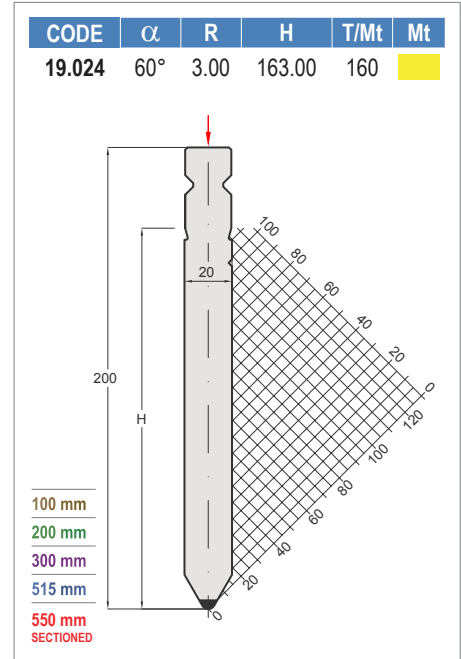
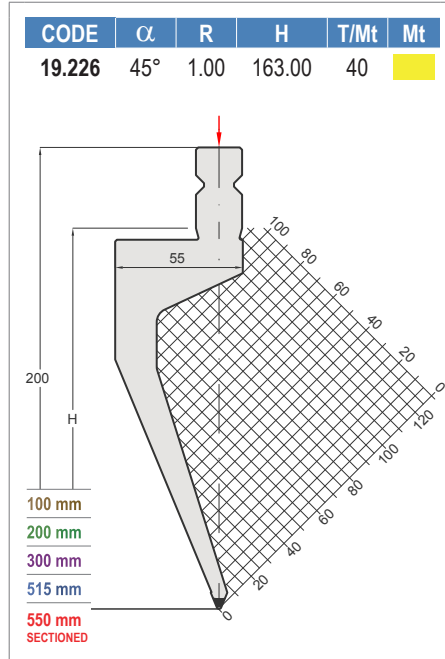
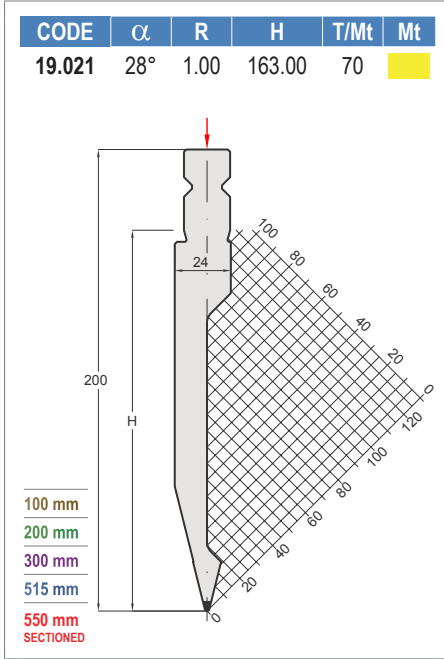

# PUNZONI / PUNCHES WILA STYLE 28° / 60° / 80° / 86° H=200

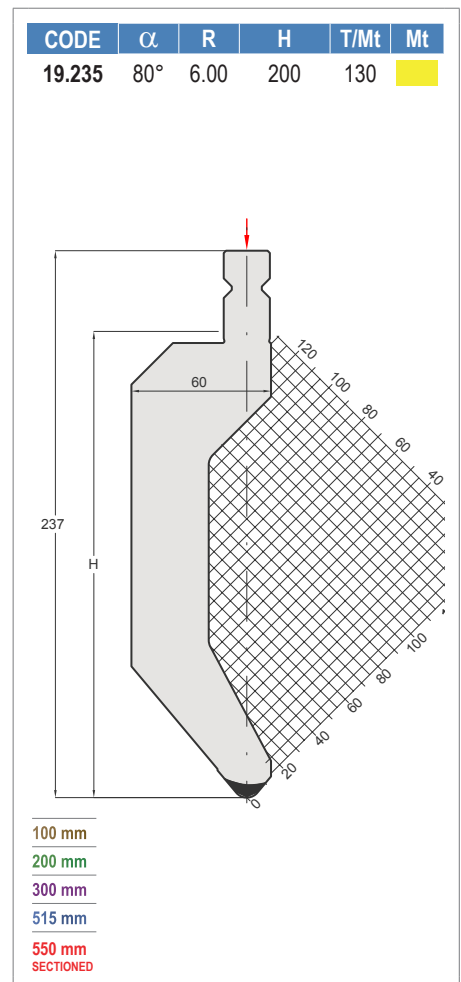
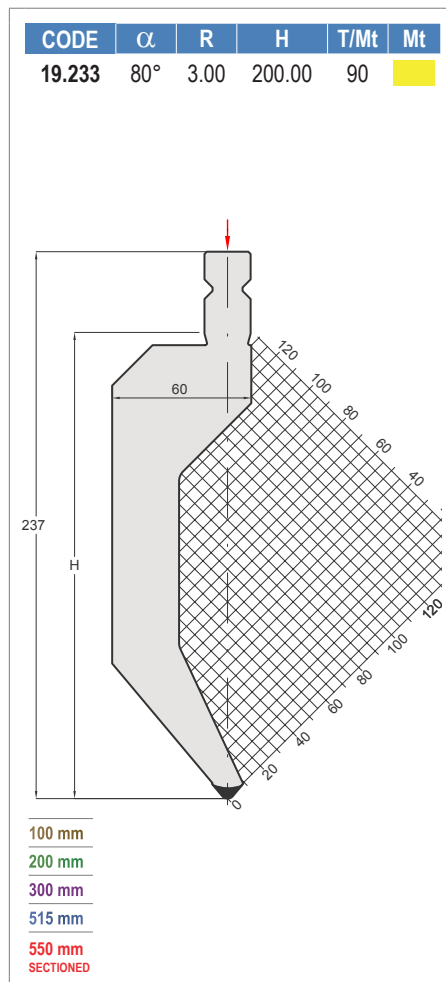
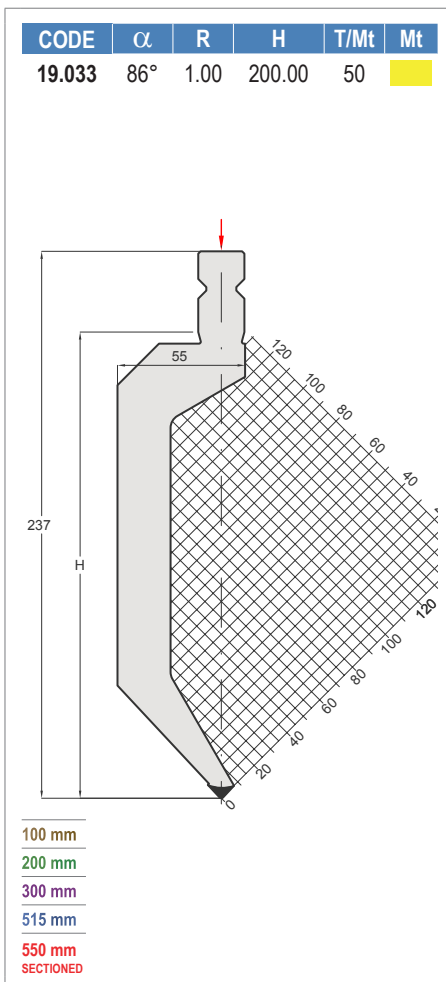
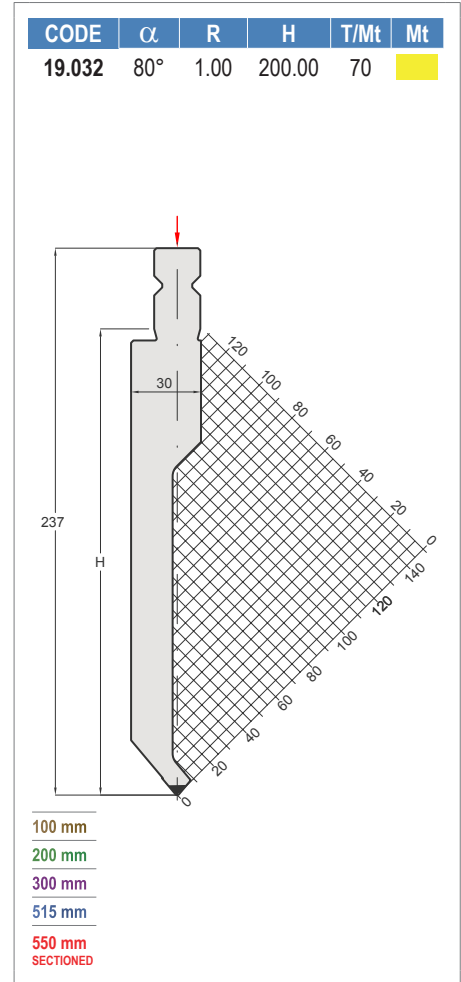
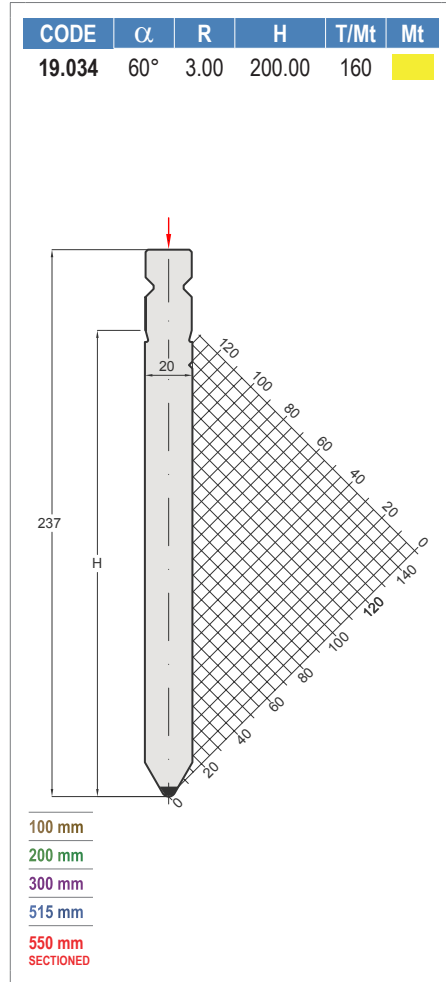
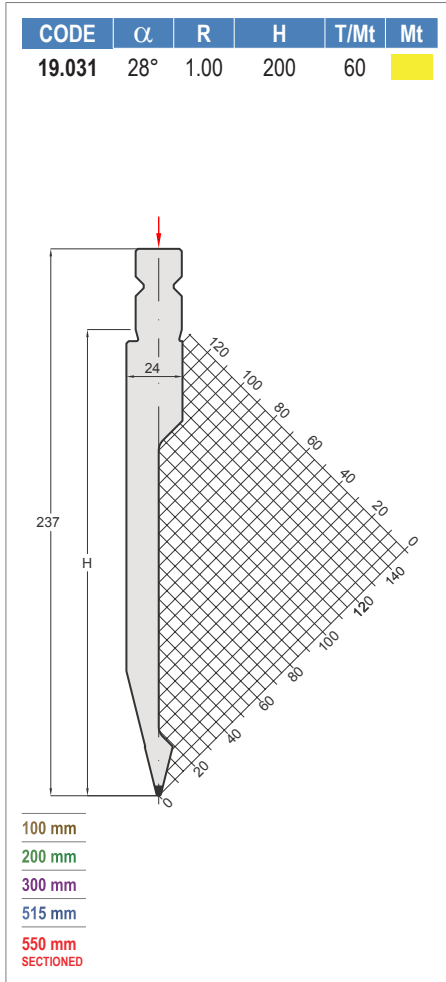

# WILA STYLE

## MATRICI

## DIES

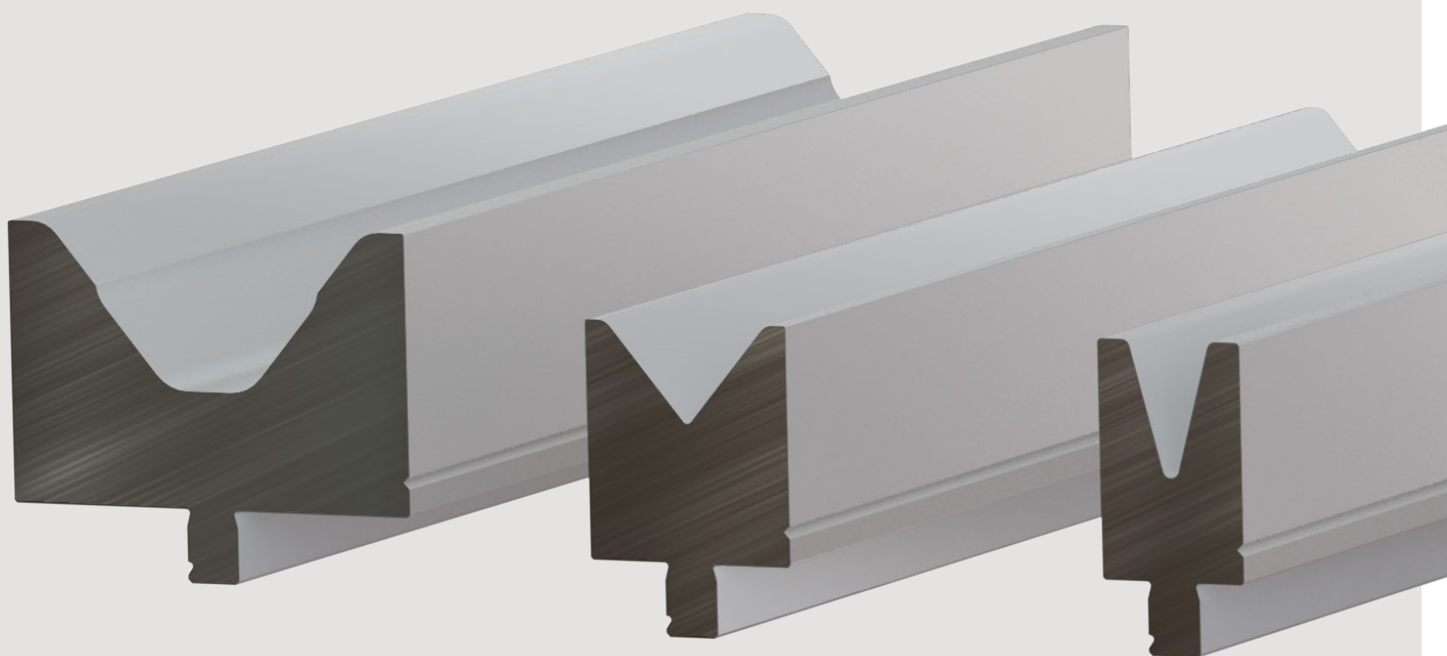

## PLATINUM LINE

WILA STYLE

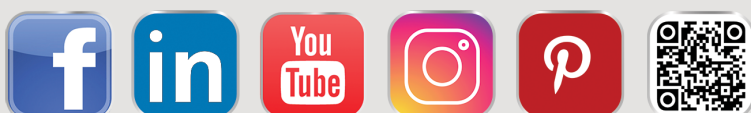

# MATRICI / DIES WILA STYLE H=55 / H=65

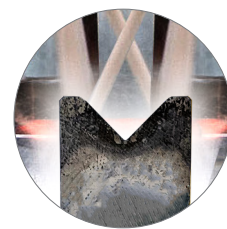

TEMPRA AD INDUZIONE 52-55 HRC  
INDUCTION HARDENED 52-55 HRC

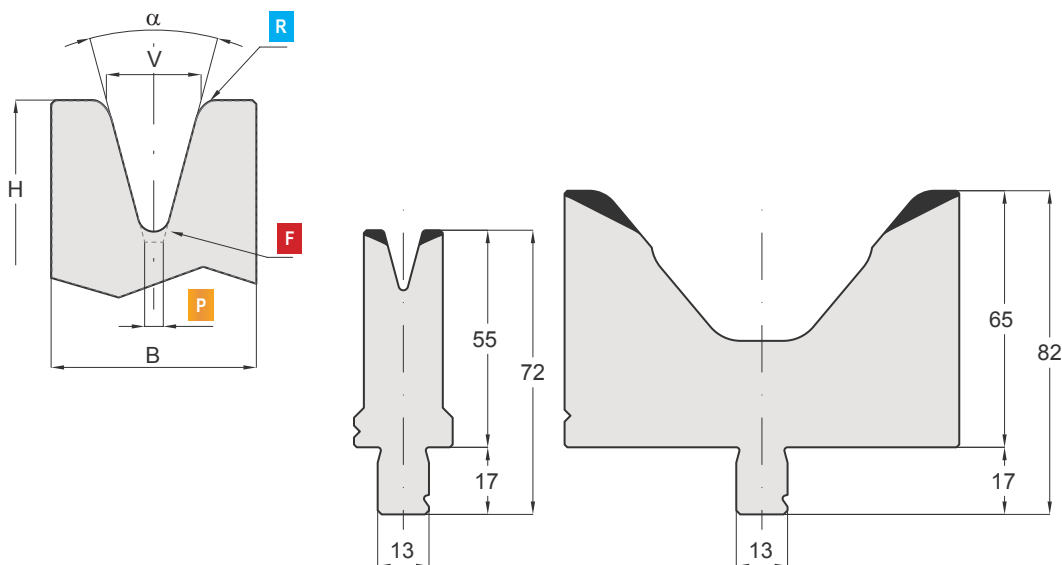

100 mm | 200 mm | 300 mm | 515 mm | 550 mm SECTIONED

LE MATRICI STANDARD SONO DISPONIBILI A MAGAZZINO NELLE LUNGHEZZE DI: 100 / 200 / 300 mm - 515 mm E FRAZIONATI (550 mm)  
THE DIES ARE AVAILABLE IN THE FOLLOWING STANDARD LENGTHS: 100 / 200 / 300 mm - 515 mm AND SECTIONED (550 mm)

<b>LEGENDA</b>	$\alpha$ = ANGOLO	V = AMPIEZZA CAVA	R = RAGGIO	H = ALTEZZA	B = STELO	T = BASE	F = FONDO MATRICE	P = PIANO
<b>LEGEND</b>	$\alpha$ = ANGLE	V = DIE OPENING	R = RADIUS	H = HEIGHT	B = BODY	T = BASE	F = BOTTOM DIE	P = FLAT

CODE	$\alpha$	V	R	H	B	T	F	T/mt	Mt
29.524	86°	4	0.40	55	10	25	R0.6	45	■
29.521	86°	6	1.00	55	16	25	R0.8	120	■
29.510	86°	8	1.00	55	16	25	R0.8	120	■
29.522	86°	10	1.00	55	20	25	R1.0	120	■
29.511	86°	12	1.00	55	20	25	R1.2	120	■
29.512	86°	16	1.50	55	25	25	R1.2	120	■
29.523	86°	20	2.00	55	30	30	R1.2	120	■
29.513	80°	24	2.50	55	35	35	R1.2	125	■
29.514	80°	30	3.00	55	40	40	R1.2	125	■
29.515	80°	40	4.00	55	50	50	R1.2	125	■
29.535	80°	50	5.00	55	75	75	R6.0	150	■
29.517	80°	80	8.00	65	100	100	P20.1	150	■
29.561	30°	6	1.00	55	16	25	R1.0	80	■
29.551	30°	8	1.00	55	16	25	R1.2	80	■
29.562	30°	10	1.00	55	20	25	R1.2	80	■
29.552	30°	12	1.00	55	20	25	R1.2	80	■
29.553	30°	16	1.50	55	30	30	R1.2	80	■
29.563	30°	20	2.00	55	35	35	R2.0	80	■
29.554	30°	24	2.50	55	40	40	R4.5	80	■

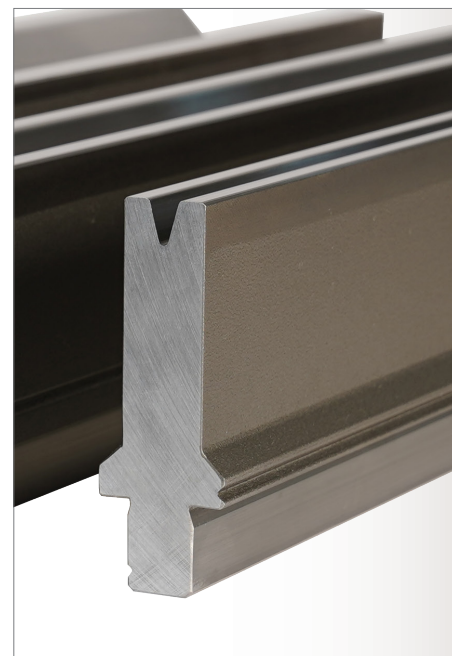



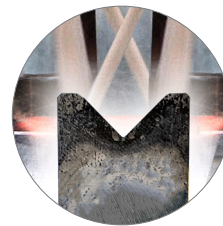
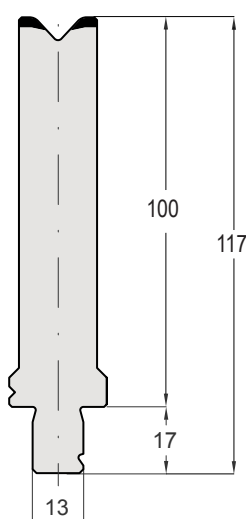
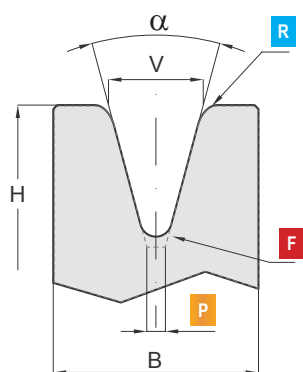

TEMPRA AD INDUZIONE 52-55 HRC  
INDUCTION HARDENED 52-55 HRC

100 mm | 200 mm | 300 mm | 515 mm | 550 mm SECTIONED

LE MATRICI STANDARD SONO DISPONIBILI A MAGAZZINO NELLE LUNGHEZZE DI: 100 / 200 / 300 mm - 515 mm E FRAZIONATI (550 mm)  
THE DIES ARE AVAILABLE IN THE FOLLOWING STANDARD LENGTHS: 100 / 200 / 300 mm - 515 mm AND SECTIONED (550 mm)

<b>LEGENDA</b>	$\alpha$ = ANGOLO	V = AMPIEZZA CAVA	R = RAGGIO	H = ALTEZZA	B = STELO	T = BASE	F = FONDO MATRICE	P = PIANO
<b>LEGEND</b>	$\alpha$ = ANGLE	V = DIE OPENING	R = RADIUS	H = HEIGHT	B = BODY	T = BASE	F = BOTTOM DIE	P = FLAT

CODE	$\alpha$	V	R	H	B	T	F	T/mt	Mt
29.336	86°	4	0.80	100	10	25	R0.8	45	■
29.321	86°	6	2.00	100	16	25	R0.8	120	■
29.290	86°	8	2.50	100	16	25	R1.0	120	■
29.322	86°	10	2.50	100	20	25	R1.2	120	■
29.291	86°	12	3.00	100	20	25	R1.2	120	■
29.292	86°	16	3.50	100	25	25	R1.2	120	■
29.323	86°	20	4.00	100	30	30	R1.2	120	■
29.293	80°	24	5.00	100	35	35	R1.2	125	■
29.324	80°	30	6.00	100	40	40	R1.2	125	■
29.325	80°	40	8.00	100	55	55	R1.2	125	■
29.326	80°	50	10.00	100	65	65	R6.0	150	■
29.297	80°	80	16.00	100	105	105	P20.1	150	■
29.361	30°	6	2.00	100	16	25	R1.0	80	■
29.351	30°	8	2.50	100	16	25	R1.0	80	■
29.362	30°	10	2.50	100	20	25	R1.6	80	■
29.352	30°	12	3.00	100	20	25	R1.2	80	■
29.353	30°	16	3.50	100	30	30	R1.2	80	■
29.363	30°	20	4.00	100	35	35	R2.0	80	■
29.354	30°	24	5.00	100	40	40	R4.0	80	■
29.330	30°	50	10.00	100	80	80	P22.7	150	■





20 H=60

# WILA STYLE PIEGASCHIACCIA HEMMING TOOLS

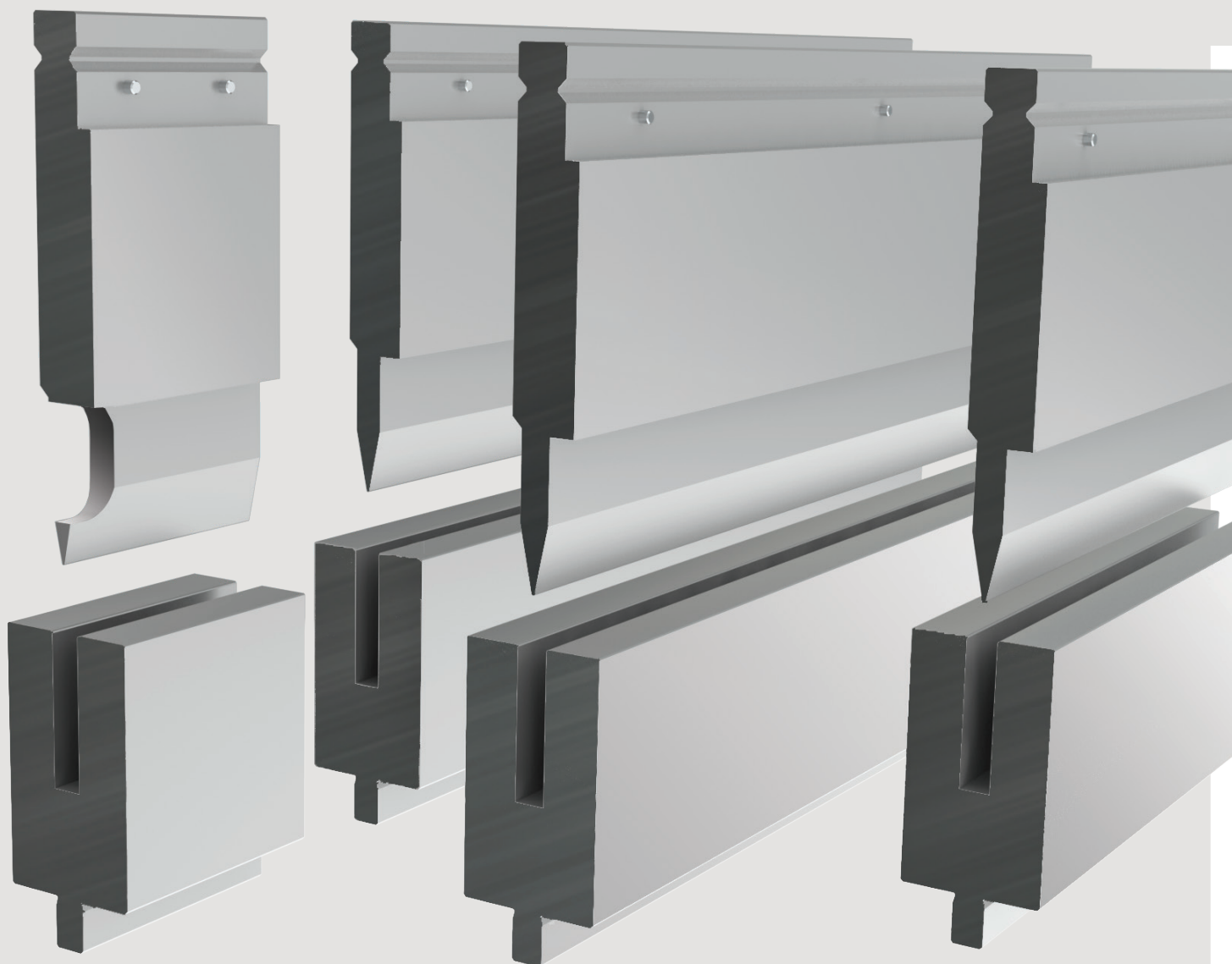

## PLATINUM LINE

WILA STYLE

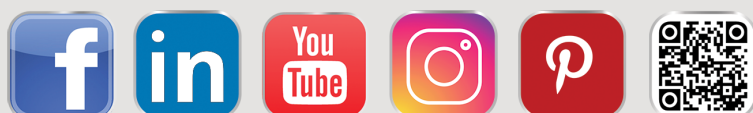

# PIEGASCHIACCIA / HEMMING TOOLS WILA STYLE

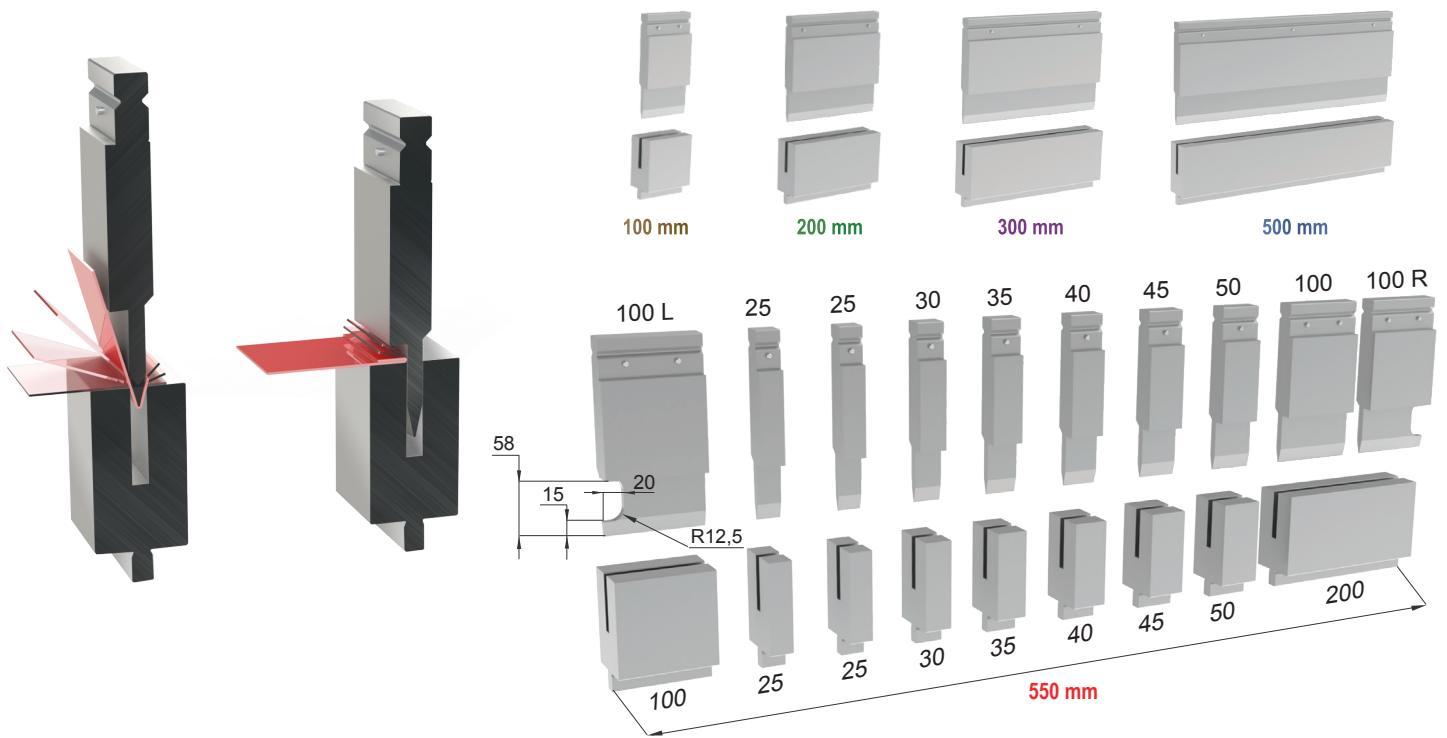

100 mm | 200 mm | 300 mm | 500 mm | 550 mm SECTIONED

IL CARICO MASSIMO DELLE SCARPETTE CORRISPONDE AL 50% DEL CARICO MASSIMO INDICATO SUL PUNZONE.  
 THE MAX LOAD OF THE HORN EXTENSIONS IS 50% OF THE MAX LOAD OF THE PUNCH.

MATERIAL ACC.R ~ 40 Kg/MM <sup>2</sup>					MATERIAL ACC.R ~ 70 Kg/MM <sup>2</sup>						
T		S		2S		T		S		2S	
MATERIAL ACC.R ~ 40 Kg/MM <sup>2</sup>					MATERIAL ACC.R ~ 70 Kg/MM <sup>2</sup>						
S (mm)	(t/m)	T (mm)	(t/m)	2S(mm)	S (mm)	(t/m)	T (mm)	(t/m)	2S(mm)		
0,6	9	3	23	1,2	0,6	15	3	35	1,2		
0,8	12	3	32	1,6	0,8	20	3	50	1,6		
1,0	15	3,5	40	2,0	1,0	25	3,5	60	2,0		
1,25	17	3,5	50	2,5	1,25	26	3,5	80	2,5		
1,5	22	4,6	63	3,0	1,5	38	4,6	95	3,0		
2,0	30	5,5	80	4,0	2,0	50	5,5	130	4,0		
2,5	55	6,5	90	5,0							
3,0	70	8,0	100	6,0							

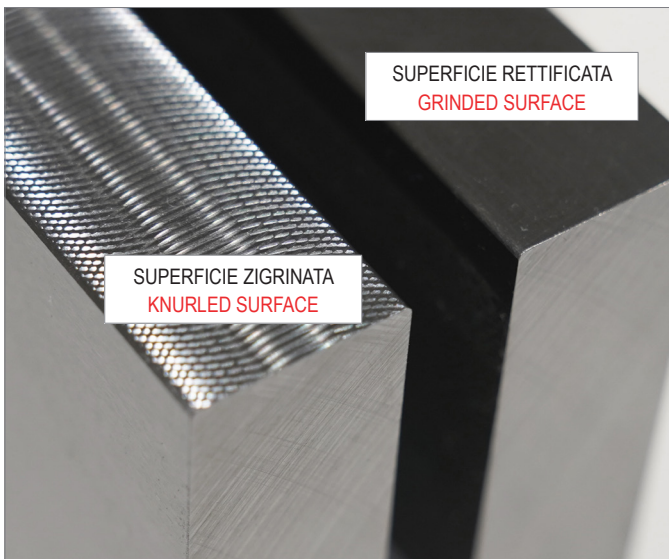

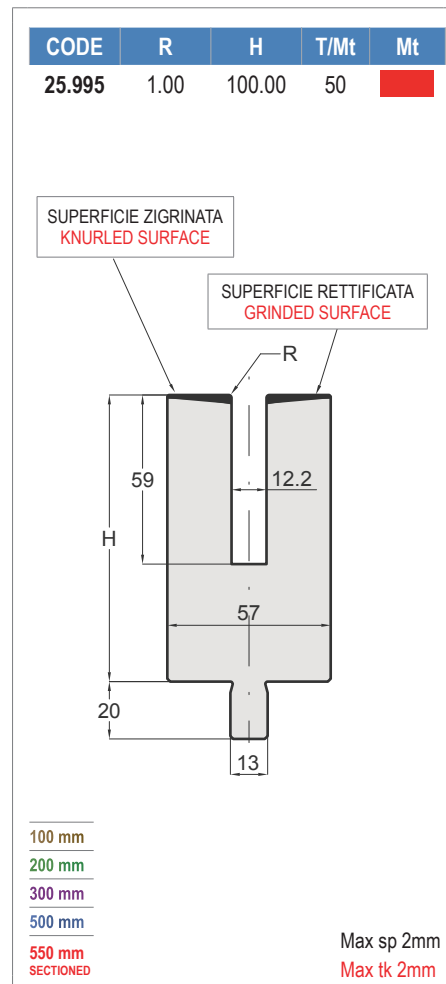
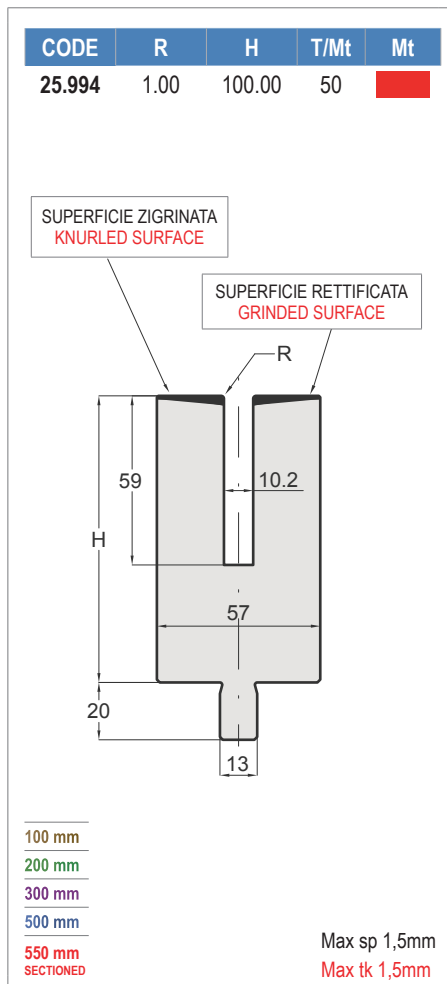
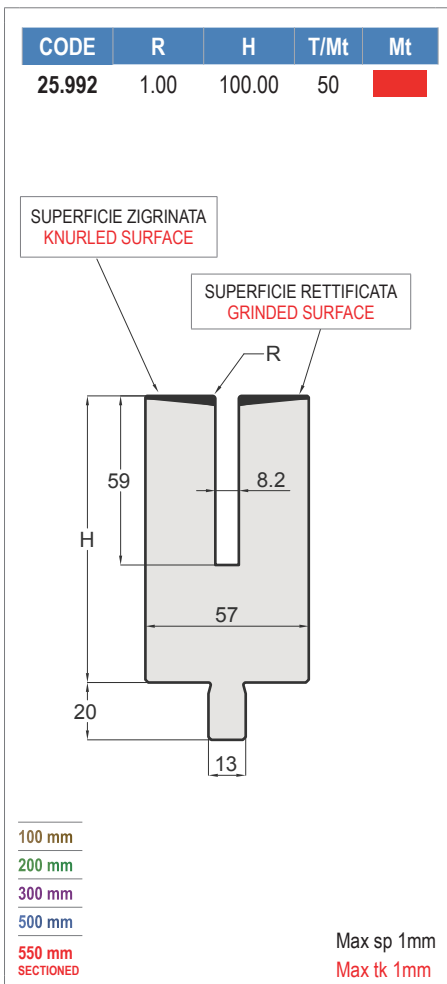
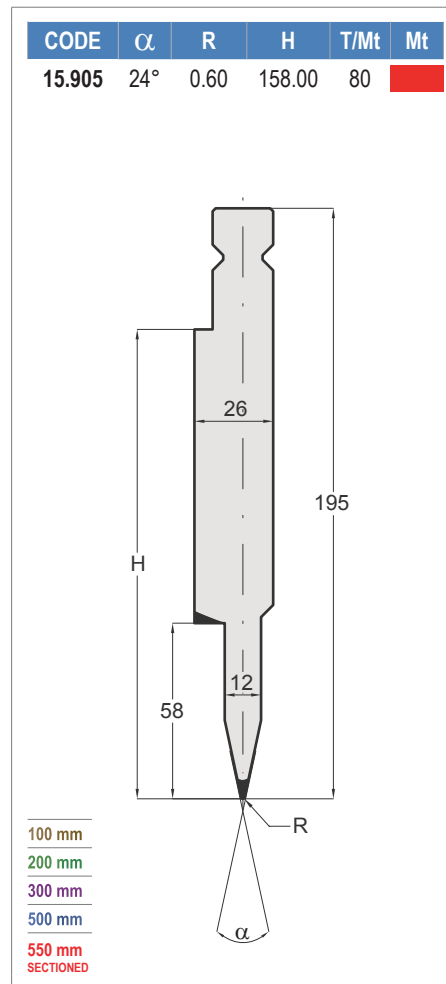
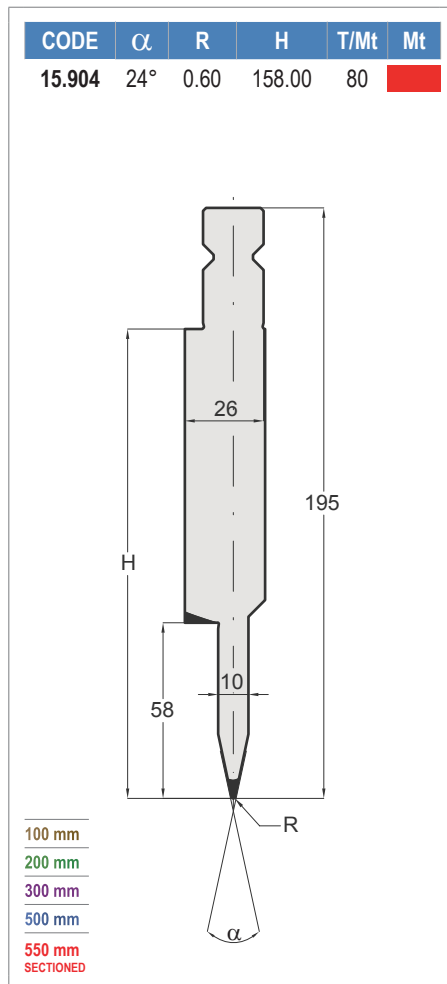
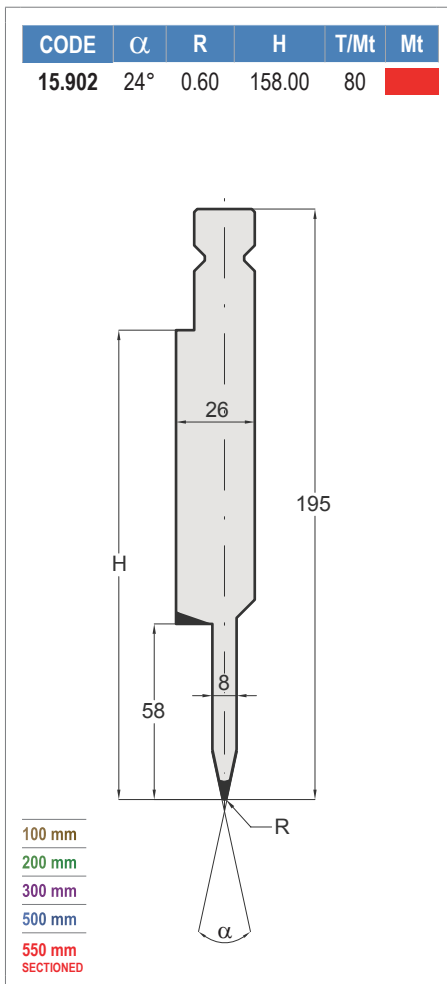

# SCHIACCIATORE / HEMMING TOOL WILA STYLE

CODE	H	T/Mt	Mt
19.041	120.00	120	

FRAZIONATO SENZA SCARPETTE  
SECTIONED WITHOUT HORNS

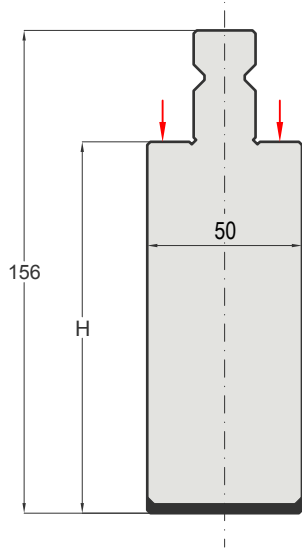

- 100 mm
- 200 mm
- 300 mm
- 515 mm
- 550 mm SECTIONED

CODE	H	T/Mt	Mt
29.384	100.00	100	

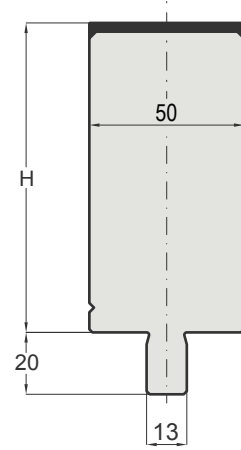

- 100 mm
- 200 mm
- 300 mm
- 515 mm
- 550 mm SECTIONED



# BYSTRONIC - BEYELER STYLE

PUNZONI

PUNCHES

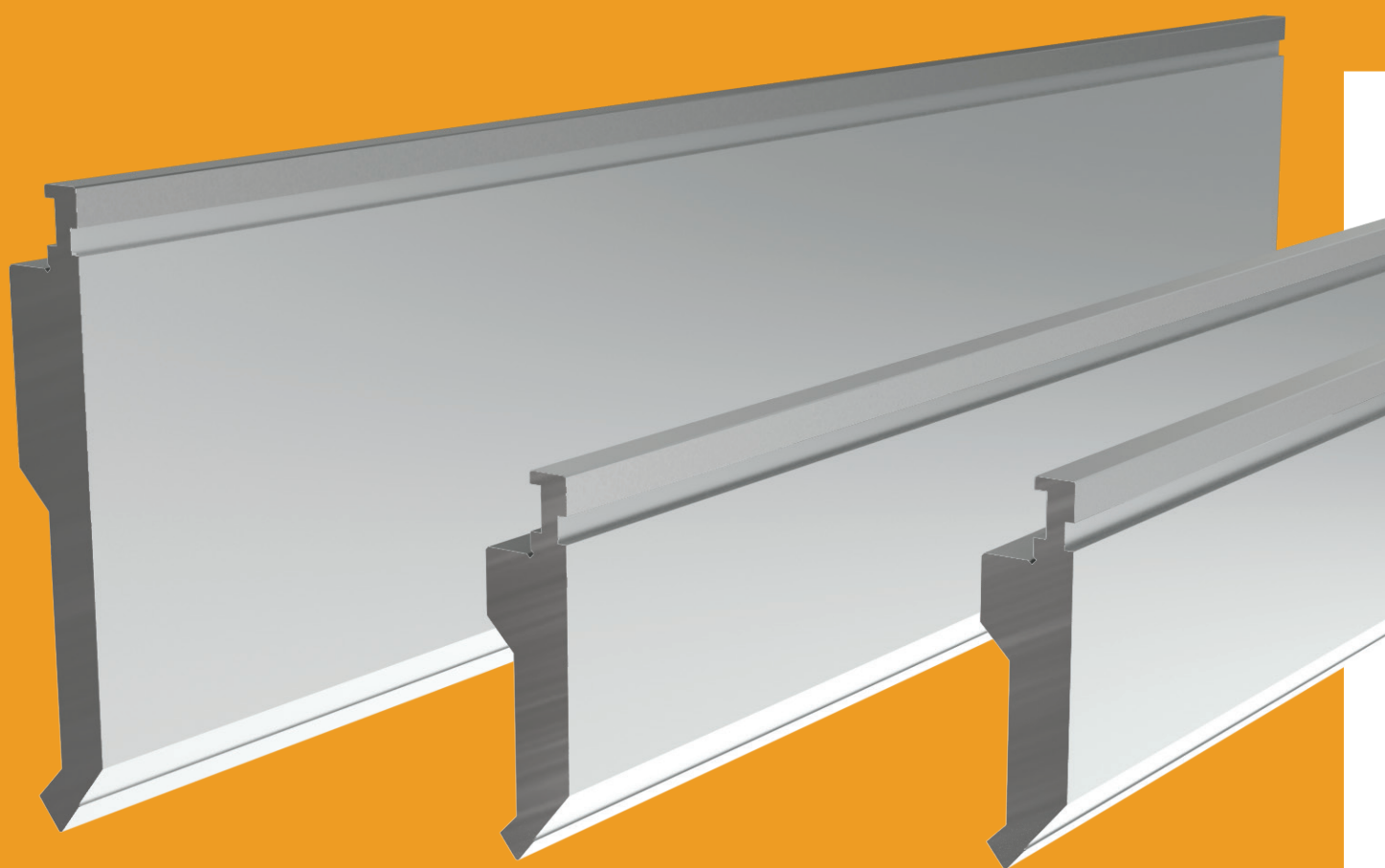

## ORANGE LINE

*BYSTRONIC - BEYELER STYLE*



# PUNZONI / PUNCHES *EURO - BYSTRONIC - BEYELER STYLE*

I PUNZONI STANDARD SONO DISPONIBILI A MAGAZZINO NELLE LUNGHEZZE DI: 100 / 200 / 300 mm - 500 mm E FRAZIONATI (550 mm)  
 THE PUNCHES ARE AVAILABLE IN THE FOLLOWING STANDARD LENGTHS: 100 / 200 / 300 mm - 500 mm AND SECTIONED (550 mm)

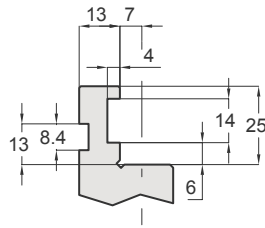
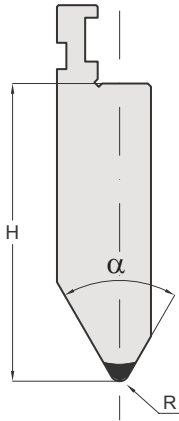

**EURO-BEYELER  
SAFAN**

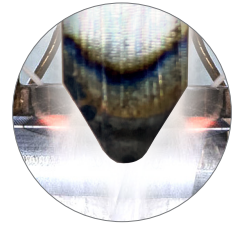

**TEMPRA AD INDUZIONE 52-55 HRC  
INDUCTION HARDENED 52-55 HRC**

<b>LEGENDA</b>	$\alpha$ = ANGOLO	R = RAGGIO	H = ALTEZZA
<b>LEGEND</b>	$\alpha$ = ANGLE	R = RADIUS	H = HEIGHT

**100 mm**

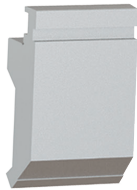

**200 mm**

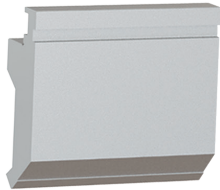

**300 mm**

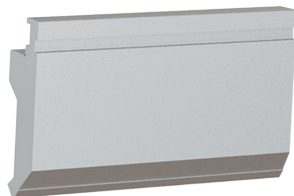

**500mm**

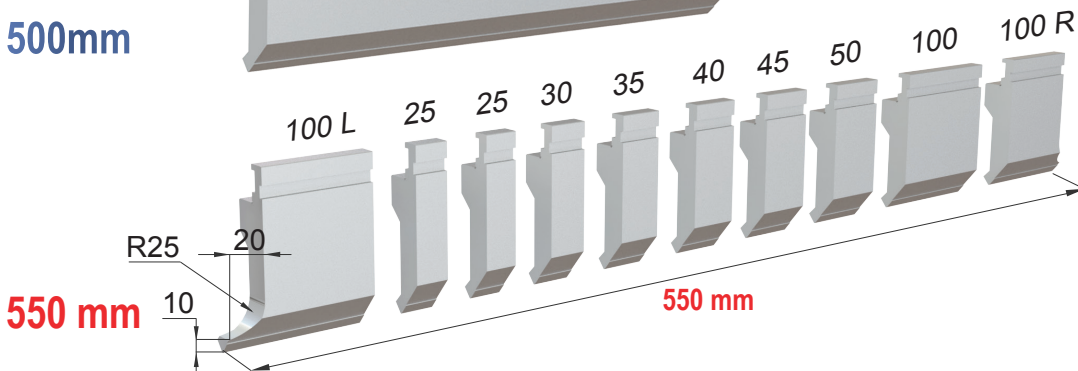
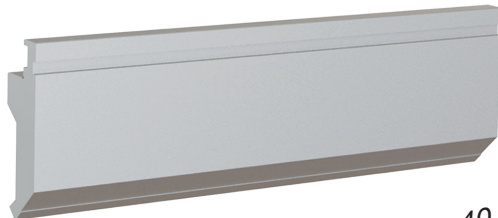

IL CARICO MASSIMO DELLE SCARPETTE CORRISPONDE AL 50% DEL CARICO MASSIMO INDICATO SUL PUNZONE.  
 THE MAX LOAD OF THE HORN EXTENSIONS IS 50% OF THE MAX LOAD OF THE PUNCH.



# PUNZONI / PUNCHES *EURO - BYSTRONIC - BEYELER STYLE* 28° / 60° / 80° / 86°

CODE	$\alpha$	R	H	T/Mt	Mt
14.040	86°	1.00	95.00	75	<span style="color: red;">■</span>

100 mm  
200 mm  
300 mm  
500 mm  
550 mm SECTIONED

CODE	$\alpha$	R	H	T/Mt	Mt
14.020	80°	1.00	95.00	75	<span style="color: red;">■</span>

100 mm  
200 mm  
300 mm  
500 mm  
550 mm SECTIONED

CODE	$\alpha$	R	H	T/Mt	Mt
14.010	60°	3.00	95.00	100	<span style="color: red;">■</span>

100 mm  
200 mm  
300 mm  
500 mm  
550 mm SECTIONED

CODE	$\alpha$	R	H	T/Mt	Mt
14.030	28°	1.00	95.00	70	<span style="color: red;">■</span>

100 mm  
200 mm  
300 mm  
500 mm  
550 mm SECTIONED

CODE	$\alpha$	R	H	T/Mt	Mt
14.060	80°	1.00	175.00	80	<span style="color: red;">■</span>

100 mm  
200 mm  
300 mm  
500 mm  
550 mm SECTIONED

CODE	$\alpha$	R	H	T/Mt	Mt
14.050	28°	1.00	175.00	100	<span style="color: red;">■</span>

100 mm  
200 mm  
300 mm  
500 mm  
550 mm SECTIONED

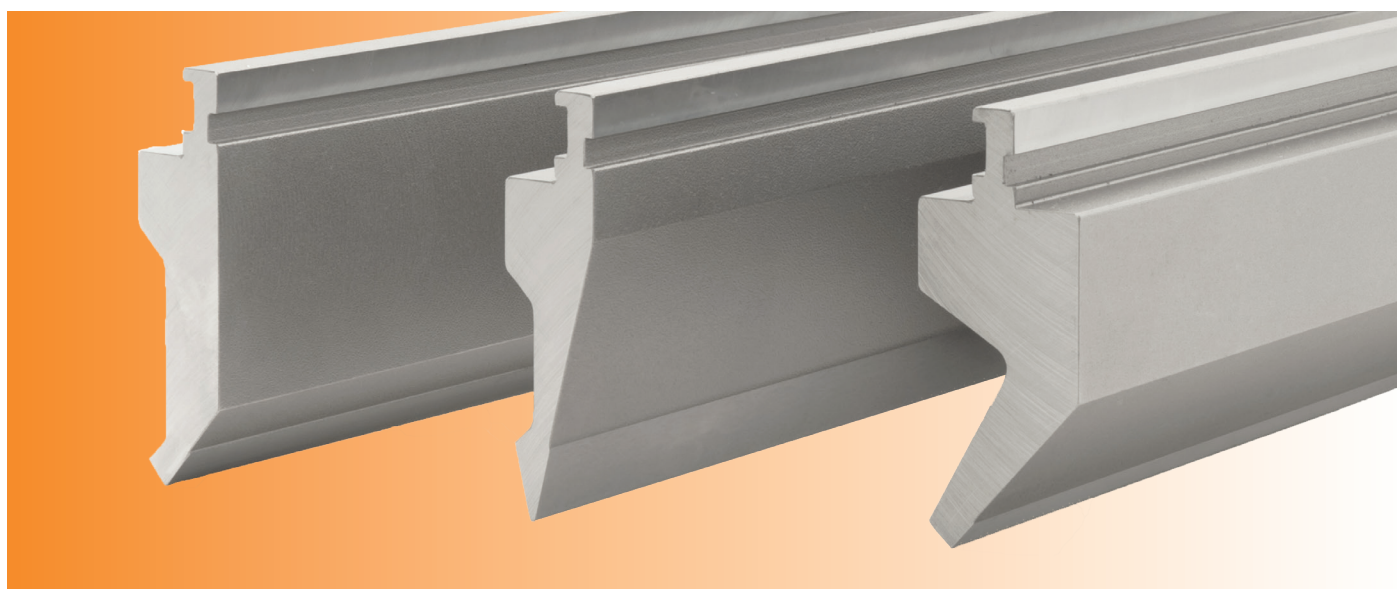

# PUNZONI / PUNCHES *BYSTRONIC - BEYELER RF-A STYLE*

I PUNZONI STANDARD SONO DISPONIBILI A MAGAZZINO NELLE LUNGHEZZE DI: 100 / 200 / 300 mm - 515 mm E FRAZIONATI (550 mm)  
 THE PUNCHES ARE AVAILABLE IN THE FOLLOWING STANDARD LENGTHS: 100 / 200 / 300 mm - 515 mm AND SECTIONED (550 mm)

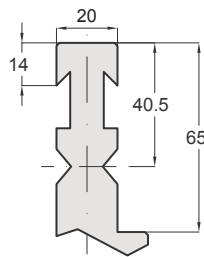
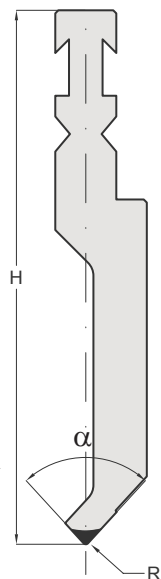

BEYELER RF-A

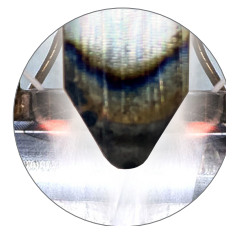

TEMPRA AD INDUZIONE 52-55 HRC  
 INDUCTION HARDENED 52-55 HRC

LEGENDA	$\alpha$ = ANGOLO	R = RAGGIO	H = ALTEZZA
LEGEND	$\alpha$ = ANGLE	R = RADIUS	H = HEIGHT

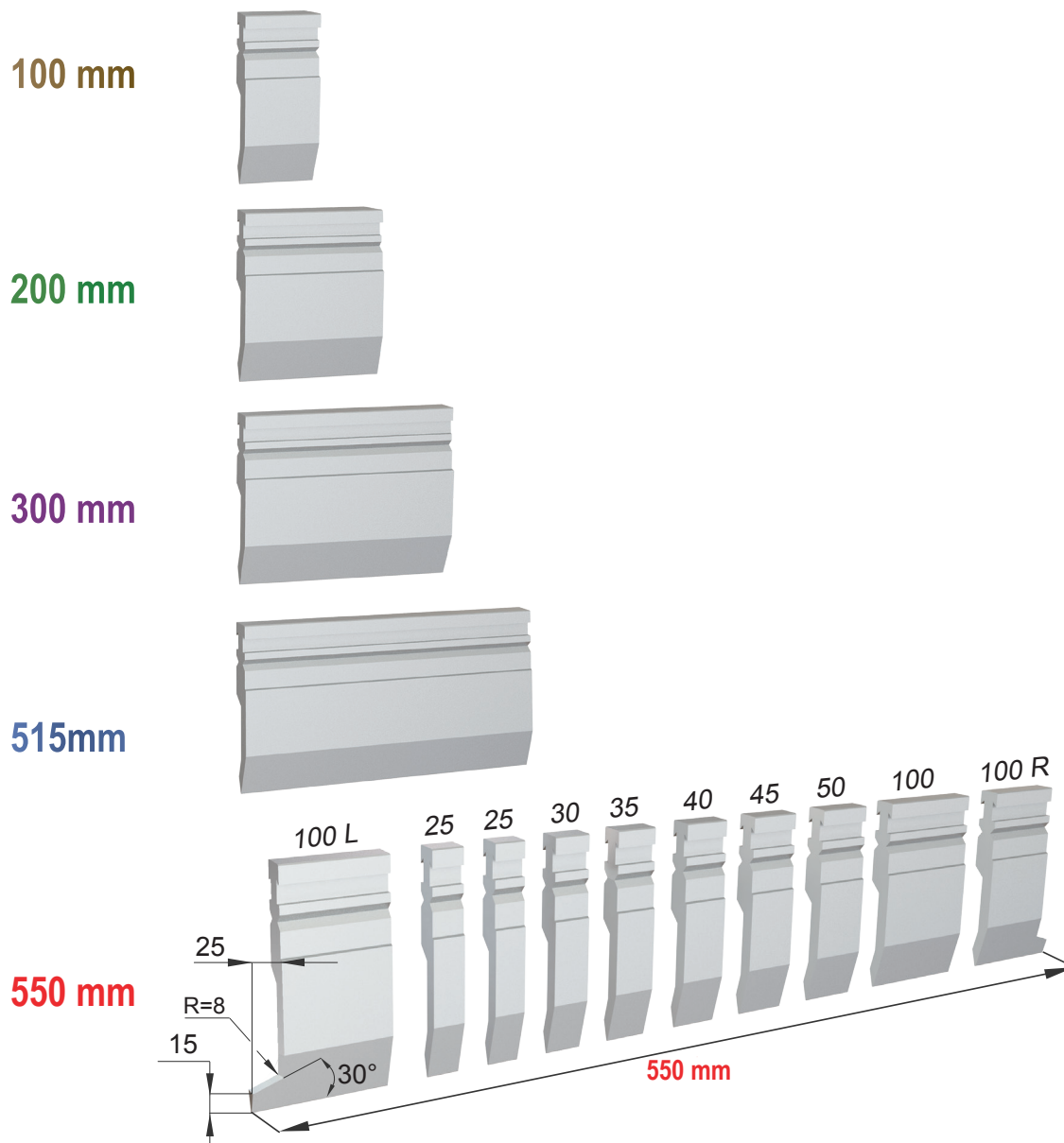

IL CARICO MASSIMO DELLE SCARPETTE CORRISPONDE AL 50% DEL CARICO MASSIMO INDICATO SUL PUNZONE.  
 THE MAX LOAD OF THE HORN EXTENSIONS IS 50% OF THE MAX LOAD OF THE PUNCH.

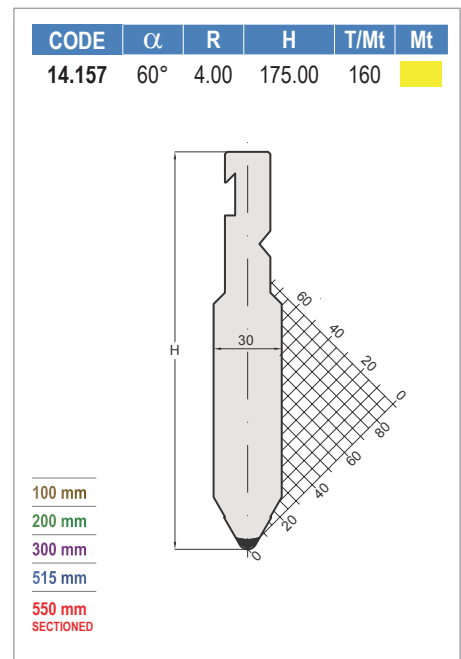
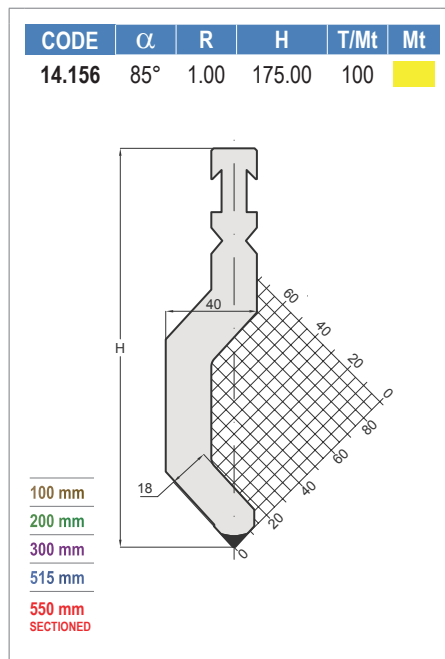
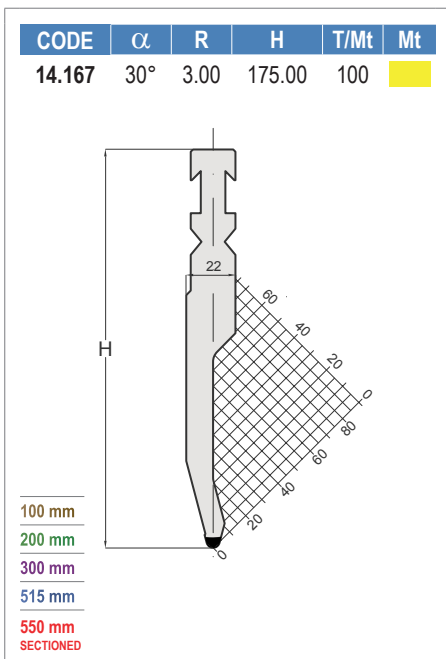
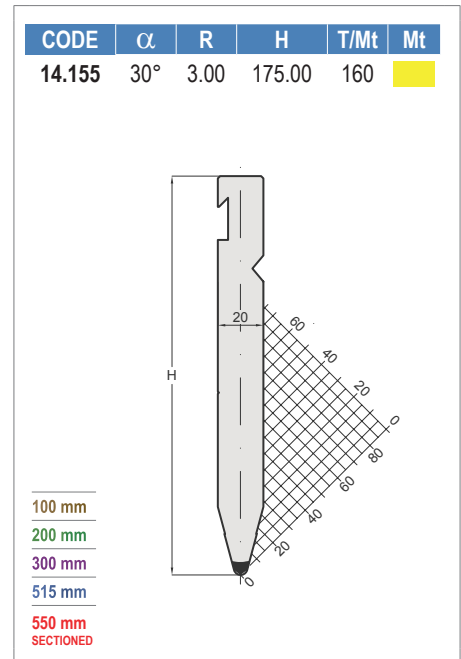
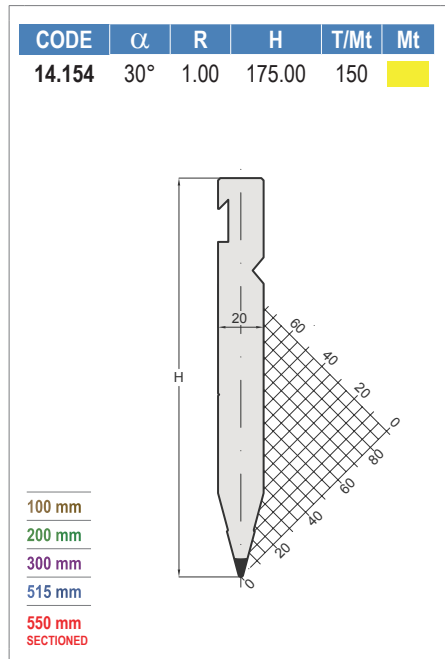
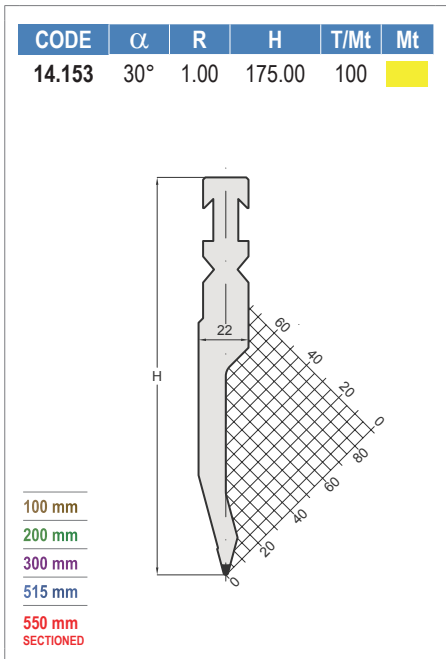
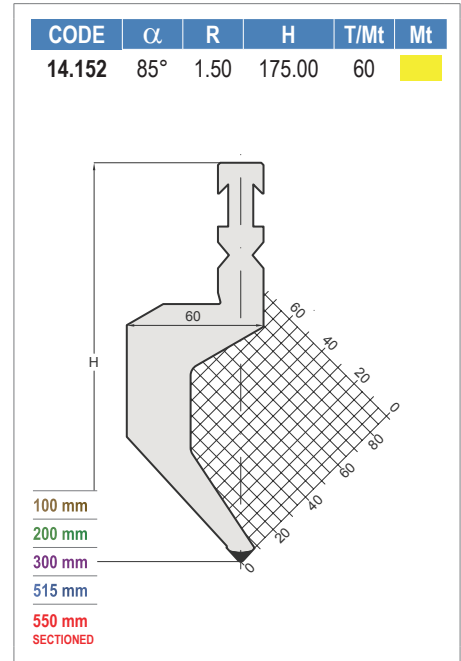
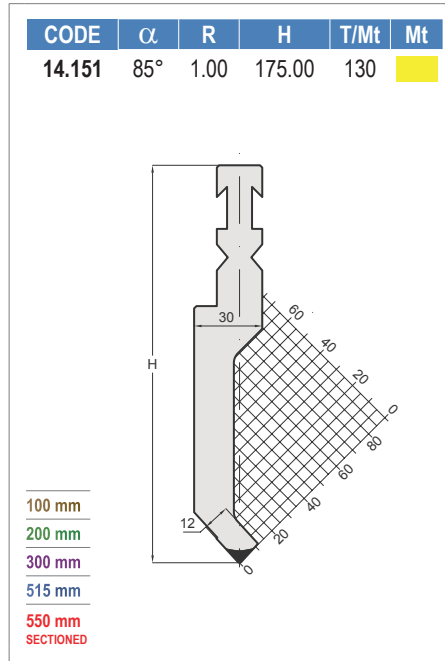
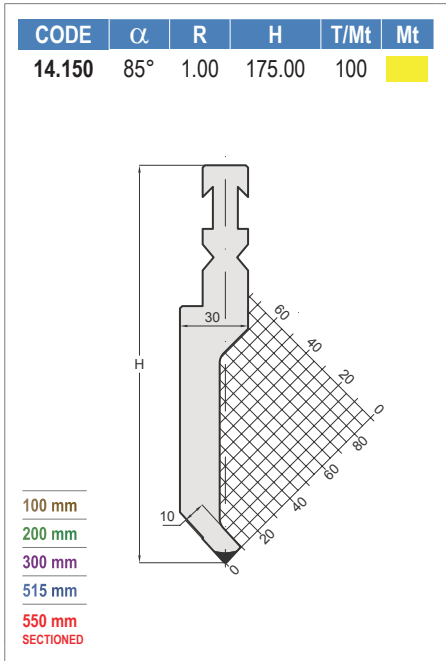

# PUNZONI / PUNCHES *BYSTRONIC - BEYELER RF-A STYLE* 60° / 85°

CODE	$\alpha$	R	H	T/Mt	Mt
14.166	85°	3.00	175.00	60	<span style="background-color: yellow;"> </span>

100 mm  
200 mm  
300 mm  
515 mm  
550 mm SECTIONED

CODE	$\alpha$	R	H	T/Mt	Mt
14.158	85°	1.00	250.00	100	<span style="background-color: yellow;"> </span>

100 mm  
200 mm  
300 mm  
515 mm  
550 mm SECTIONED

CODE	$\alpha$	R	H	T/Mt	Mt
14.159	85°	1.00	250.00	140	<span style="background-color: yellow;"> </span>

100 mm  
200 mm  
300 mm  
515 mm  
550 mm SECTIONED

CODE	$\alpha$	R	H	T/Mt	Mt
14.168	85°	3.00	250.00	60	<span style="background-color: yellow;"> </span>

100 mm  
200 mm  
300 mm  
515 mm  
550 mm SECTIONED

CODE	$\alpha$	R	H	T/Mt	Mt
14.160	85°	1.50	250.00	60	<span style="background-color: yellow;"> </span>

100 mm  
200 mm  
300 mm  
515 mm  
550 mm SECTIONED

CODE	$\alpha$	R	H	T/Mt	Mt
14.165	60°	4.00	250.00	160	<span style="background-color: yellow;"> </span>

100 mm  
200 mm  
300 mm  
515 mm  
550 mm SECTIONED

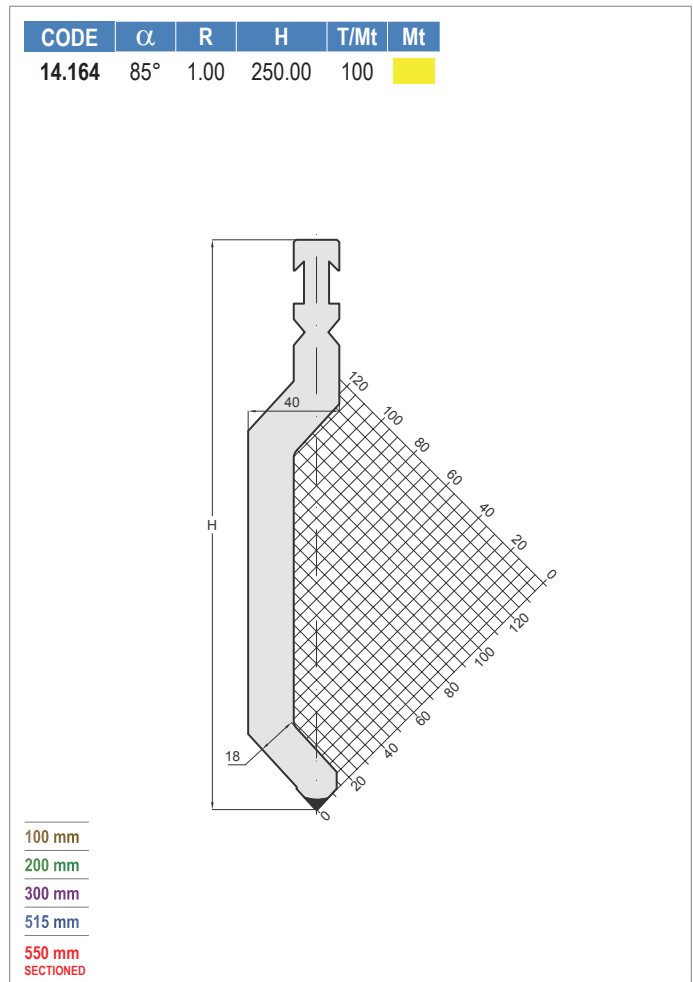
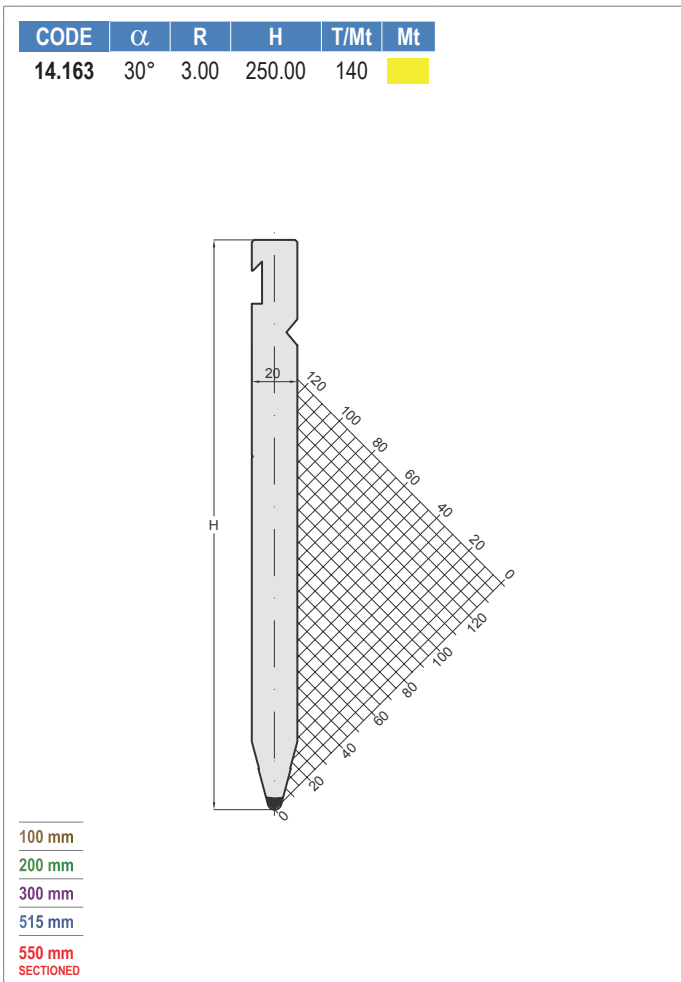
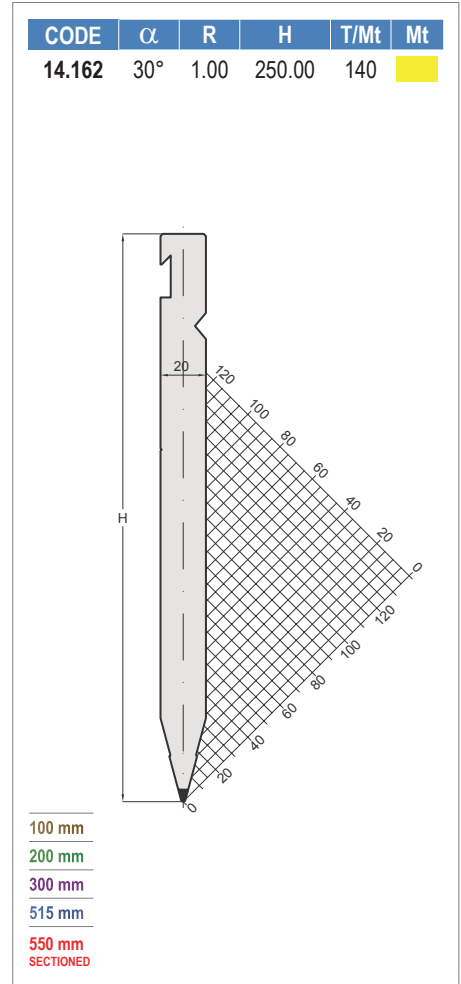
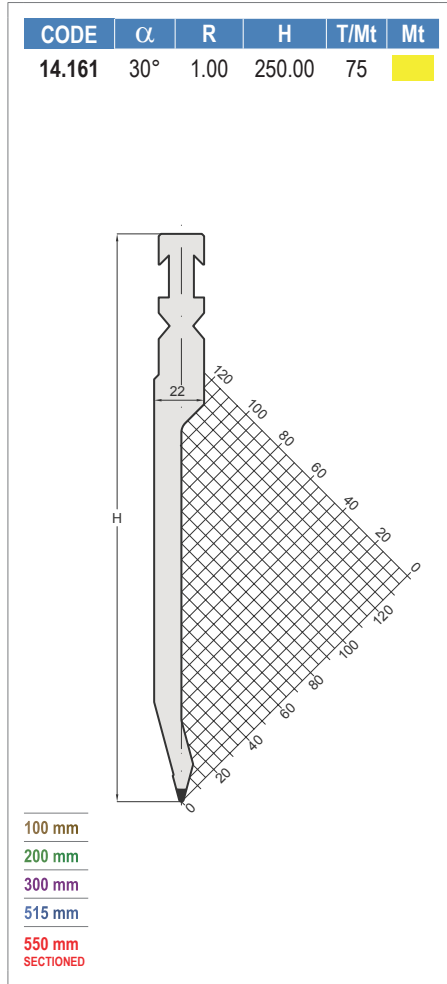
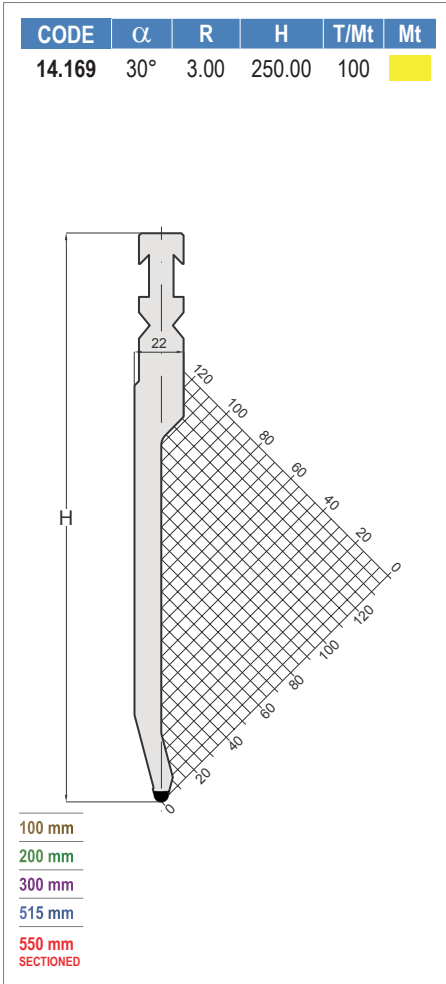

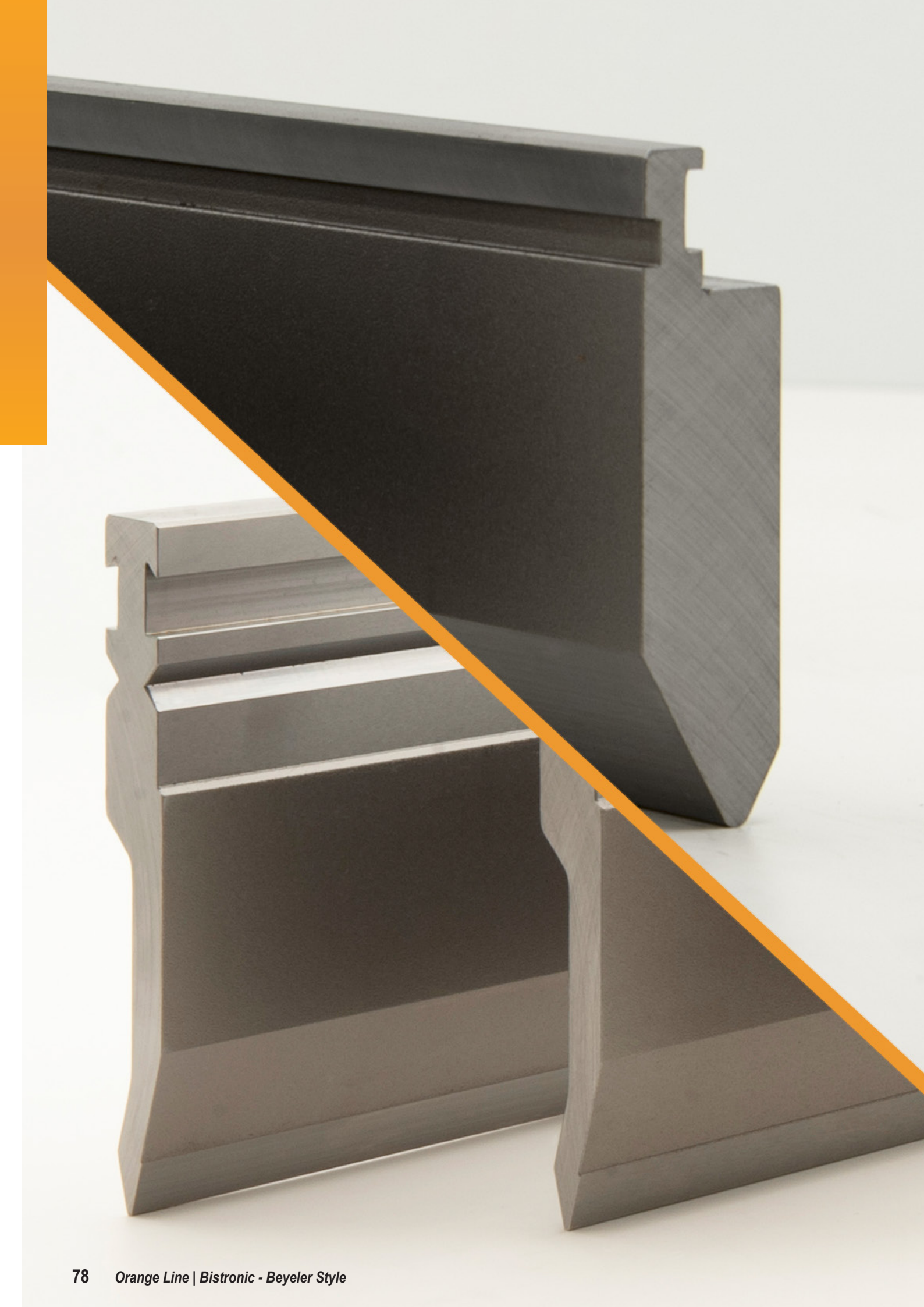

# BYSTRONIC - BEYELER STYLE

MATRICI

DIES

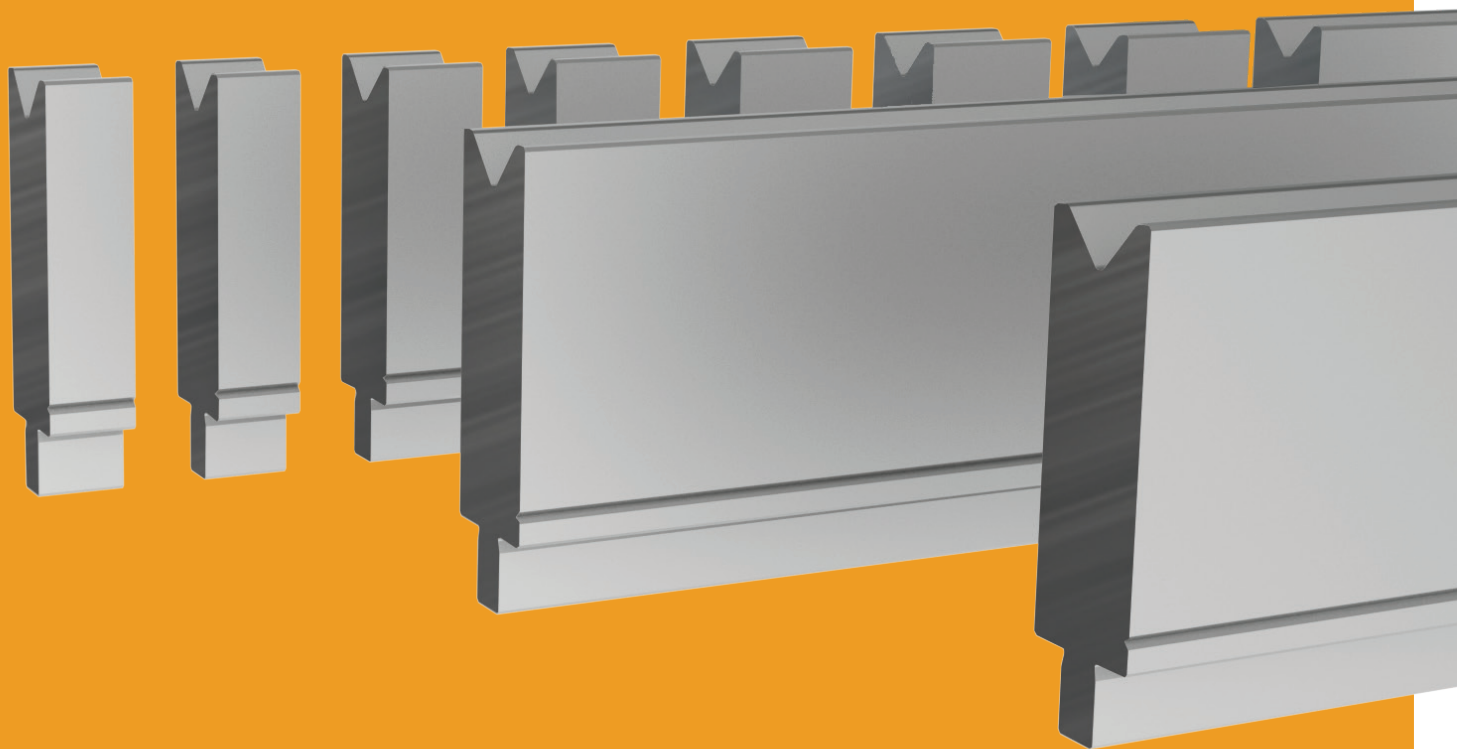

## ORANGE LINE

*BYSTRONIC - BEYELER STYLE*



# MATRICI / DIES *BYSTRONIC - BEYELER STYLE H=55 -65 -85*

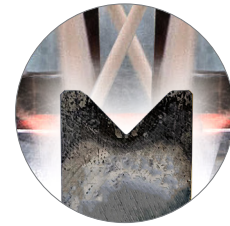
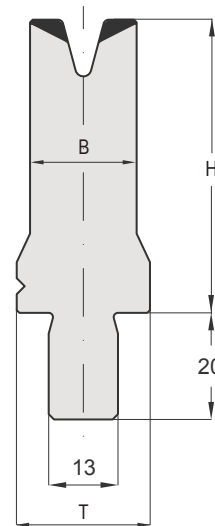
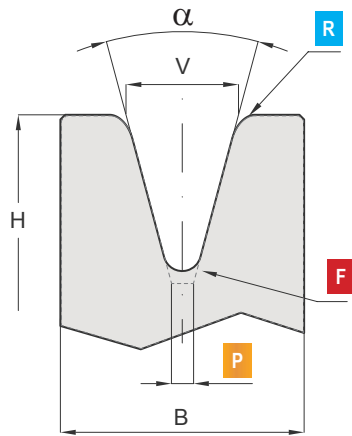

TEMPRA AD INDUZIONE 52-55 HRC  
INDUCTION HARDENED 52-55 HRC

100 mm | 200 mm | 300 mm | 515 mm | 550 mm SECTIONED

LE MATRICI STANDARD SONO DISPONIBILI A MAGAZZINO NELLE LUNGHEZZE DI: 100 / 200 / 300 mm - 515 mm E FRAZIONATI (550 mm)  
THE DIES ARE AVAILABLE IN THE FOLLOWING STANDARD LENGTHS: 100 / 200 / 300 mm - 515 mm AND SECTIONED (550 mm)

<b>LEGENDA</b>	$\alpha$ = ANGOLO	V = AMPIEZZA CAVA	R = RAGGIO	H = ALTEZZA	B = STELO	T = BASE	F = FONDO MATRICE	P = PIANO
<b>LEGEND</b>	$\alpha$ = ANGLE	V = DIE OPENING	R = RADIUS	H = HEIGHT	B = BODY	T = BASE	F = BOTTOM DIE	P = FLAT

CODE	$\alpha$	V	R	H	B	T	F	T/mt	Mt
24.403	85°	6	0,75	55	20	25	R0,5	80	■
24.404	85°	6	0,75	55	12	25	R0,5	80	■
24.405	85°	8	0,75	55	20	25	R0,5	85	■
24.406	85°	8	0,75	55	14	25	R0,5	80	■
24.407	85°	10	1,00	55	20	25	R0,5	80	■
24.408	85°	10	1,00	55	16	25	R0,5	70	■
24.409	85°	12	1,50	55	25	25	R0,5	90	■
24.410	85°	12	1,50	55	18	25	R0,5	70	■
24.411	85°	16	2,00	55	30	30	R0,5	120	■
24.412	85°	16	2,00	55	24	30	R0,5	100	■
24.413	85°	20	2,50	55	30	30	R1,0	140	■
24.414	85°	24	3,00	55	40	40	R1,0	170	■
24.415	85°	32	4,00	55	48	48	R2,0	250	■
24.080	80°	80	10,00	65	100	100	P15,0	140	■
24.180	80°	100	12,00	85	125	125	P15,0	175	■
24.040	60°	40	5,00	55	55	55	R5,0	110	■
24.050	60°	50	5,00	55	70	70	P15,0	100	■
24.060	60°	60	7,00	65	80	80	P15,0	100	■
24.453	30°	6	0,75	55	20	25	P1,0	28	■
24.454	30°	6	0,75	55	12	25	P1,0	11	■
24.455	30°	8	1,00	55	20	25	P2,0	30	■
24.456	30°	8	1,00	55	14	25	P2,0	11	■
24.457	30°	10	1,00	55	20	25	P2,0	20	■
24.458	30°	10	1,00	55	16	25	P2,0	10	■
24.459	30°	12	1,50	55	25	25	P2,0	25	■
24.460	30°	12	1,50	55	18	25	P2,0	10	■
24.017	30°	16	2,00	55	30	30	P5,0	30	■
24.462	30°	16	2,00	55	24	30	P5,0	15	■
24.320	30°	20	2,50	55	30	30	P5,0	18	■
24.018	30°	24	3,00	55	40	40	P8,0	33	■
24.465	30°	32	4,00	55	48	48	P14,0	34	■



# MATRICI / DIES BYSTRONIC - BEYELER STYLE H=100 - 105

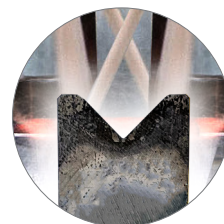
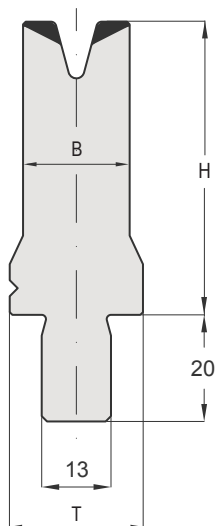
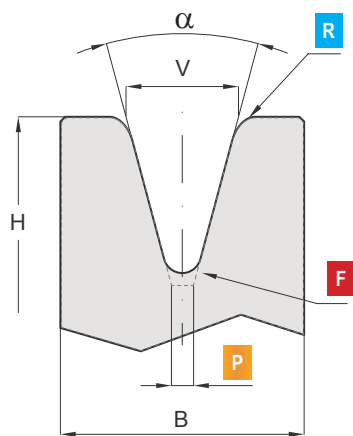

TEMPRA AD INDUZIONE 52-55 HRC  
INDUCTION HARDENED 52-55 HRC

100 mm | 200 mm | 300 mm | 515 mm | 550 mm SECTIONED

LE MATRICI STANDARD SONO DISPONIBILI A MAGAZZINO NELLE LUNGHEZZE DI: 100 / 200 / 300 mm - 515 mm E FRAZIONATI (550 mm)  
THE DIES ARE AVAILABLE IN THE FOLLOWING STANDARD LENGTHS: 100 / 200 / 300 mm - 515 mm AND SECTIONED (550 mm)

LEGENDA	$\alpha$ = ANGOLO	V = AMPIEZZA CAVA	R = RAGGIO	H = ALTEZZA	B = STELO	T = BASE	F = FONDO MATRICE	P = PIANO
LEGEND	$\alpha$ = ANGLE	V = DIE OPENING	R = RADIUS	H = HEIGHT	B = BODY	T = BASE	F = BOTTOM DIE	P = FLAT

CODE	$\alpha$	V	R	H	B	T	F	T/mt	Mt
24.503	85°	6	0,75	100	20	25	R0,5	80	■
24.504	85°	6	0,75	100	12	25	R0,5	80	■
24.505	85°	8	0,75	100	20	25	R0,5	85	■
24.506	85°	8	0,75	100	14	25	R0,5	80	■
24.507	85°	10	1,00	100	20	25	R0,5	80	■
24.508	85°	10	1,00	100	16	25	R0,5	70	■
24.509	85°	12	1,50	100	25	25	R0,5	90	■
24.510	85°	12	1,50	100	18	25	R0,5	70	■
24.511	85°	16	2,00	100	30	30	R0,5	120	■
24.512	85°	16	2,00	100	24	30	R0,5	100	■
24.513	85°	20	2,50	100	30	30	R1,0	140	■
24.514	85°	24	3,00	100	40	40	R1,0	170	■
24.515	85°	32	4,00	100	48	48	R2,0	250	■
24.580	80°	80	10,00	100	100	100	P15,0	140	■
24.600	80°	120	15,00	105	160	160	P20,0	220	■
24.540	60°	40	5,00	100	55	55	R5,0	110	■
24.550	60°	50	5,00	100	70	70	P15,0	100	■
24.570	60°	60	7,00	100	80	80	P15,0	100	■
24.553	30°	6	0,75	100	20	25	P1,0	28	■
24.554	30°	6	0,75	100	12	25	P1,0	11	■
24.555	30°	8	1,00	100	20	25	P2,0	30	■
24.556	30°	8	1,00	100	14	25	P2,0	11	■
24.557	30°	10	1,00	100	20	25	P2,0	20	■
24.558	30°	10	1,00	100	16	25	P2,0	10	■
24.559	30°	12	1,50	100	25	25	P2,0	25	■
24.560	30°	12	1,50	100	18	25	P2,0	10	■
24.561	30°	16	2,00	100	30	30	P5,0	30	■
24.562	30°	16	2,00	100	24	25	P5,0	15	■
24.563	30°	20	2,50	100	30	30	P5,0	18	■
24.564	30°	24	3,00	100	40	40	P8,0	33	■
24.565	30°	32	4,00	100	48	48	P14,0	34	■



# BYSTRONIC - BEYELER STYLE

PIEGASCHIACCIA

HEMMING TOOLS

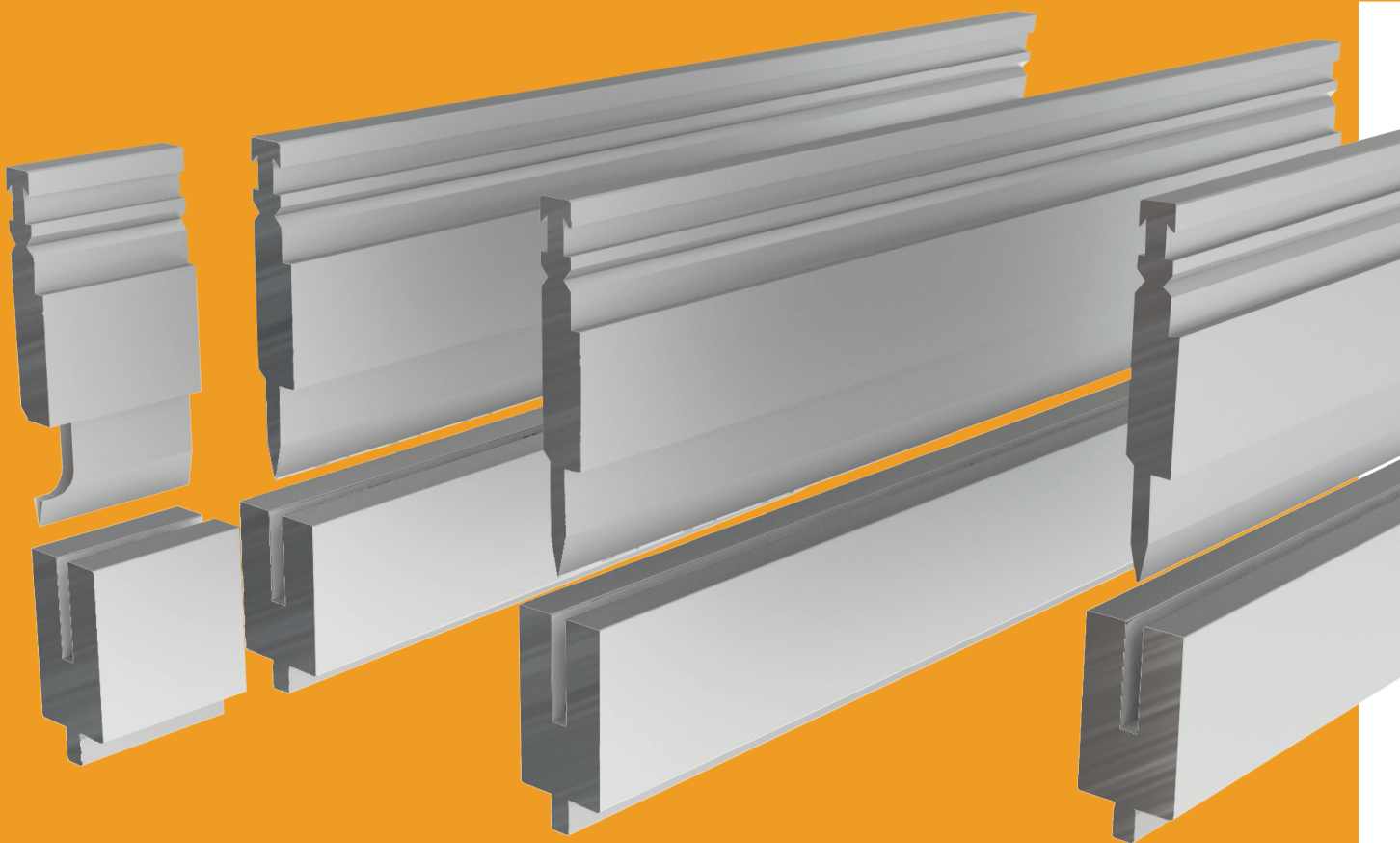

## ORANGE LINE

*BYSTRONIC - BEYELER STYLE*



# PIEGASCHIACCIA / HEMMING TOOLS **BYSTRONIC - BEYELER STYLE**

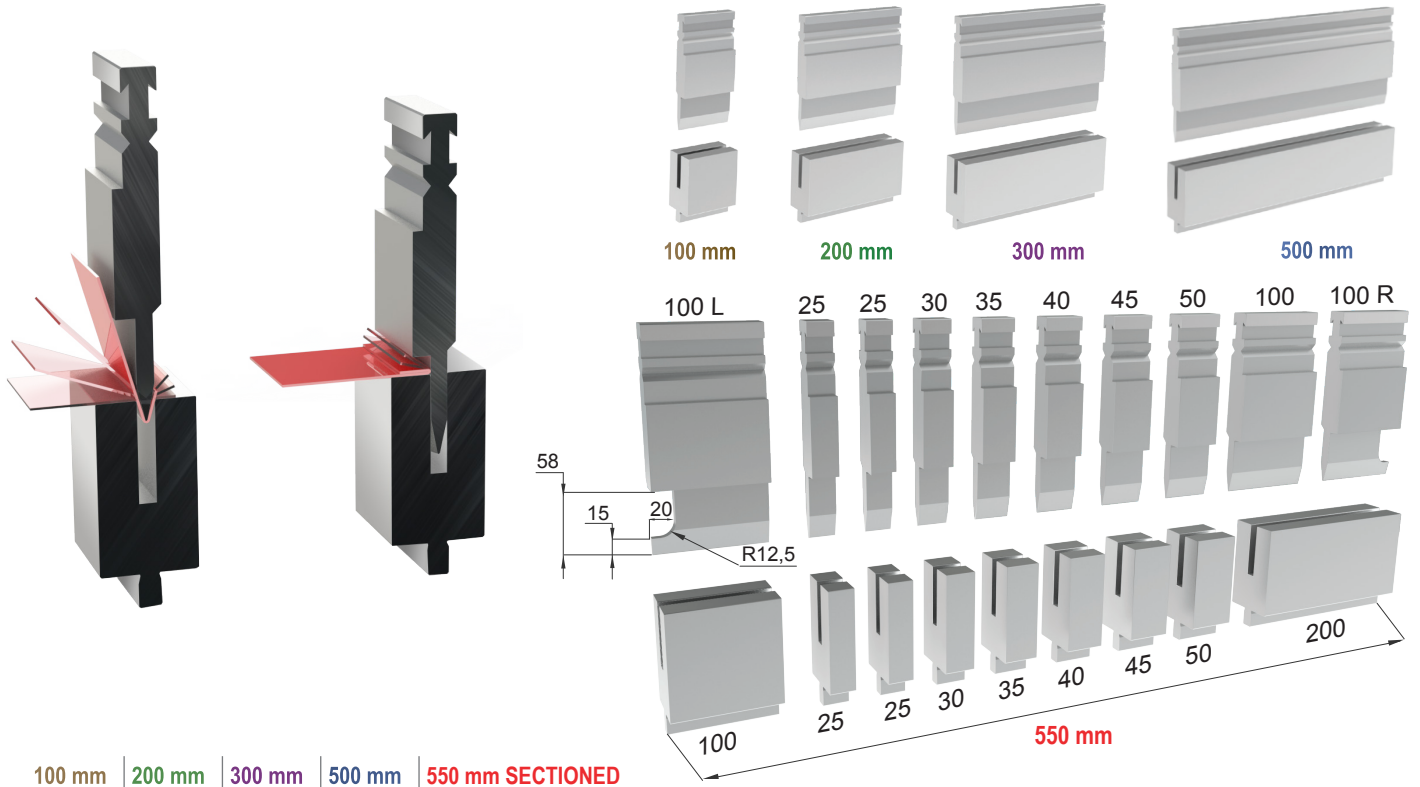

100 mm | 200 mm | 300 mm | 500 mm | 550 mm SECTIONED

IL CARICO MASSIMO DELLE SCARPETTE CORRISPONDE AL 50% DEL CARICO MASSIMO INDICATO SUL PUNZONE.  
 THE MAX LOAD OF THE HORN EXTENSIONS IS 50% OF THE MAX LOAD OF THE PUNCH.

MATERIAL ACC.R ~ 40 Kg/MM <sup>2</sup>					MATERIAL ACC.R ~ 70 Kg/MM <sup>2</sup>				
S (mm)	(t/m)	T (mm)	(t/m)	2S(mm)	S (mm)	(t/m)	T (mm)	(t/m)	2S(mm)
0,6	9	3	23	1,2	0,6	15	3	35	1,2
0,8	12	3	32	1,6	0,8	20	3	50	1,6
1,0	15	3,5	40	2,0	1,0	25	3,5	60	2,0
1,25	17	3,5	50	2,5	1,25	26	3,5	80	2,5
1,5	22	4,6	63	3,0	1,5	38	4,6	95	3,0
2,0	30	5,5	80	4,0	2,0	50	5,5	130	4,0
2,5	55	6,5	90	5,0					
3,0	70	8,0	100	6,0					

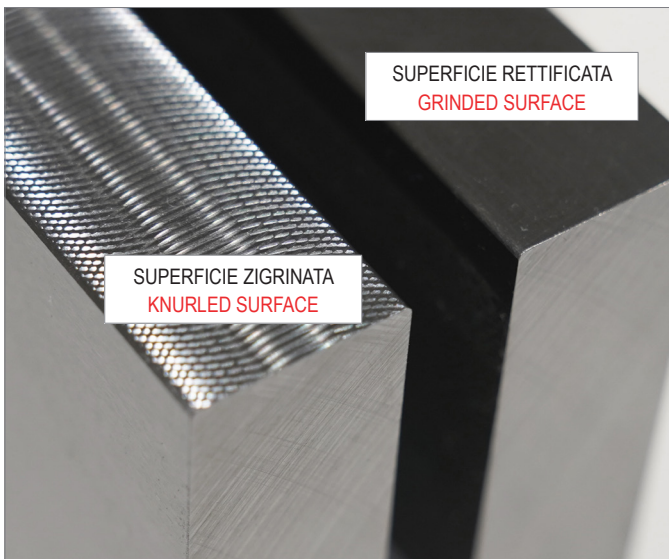

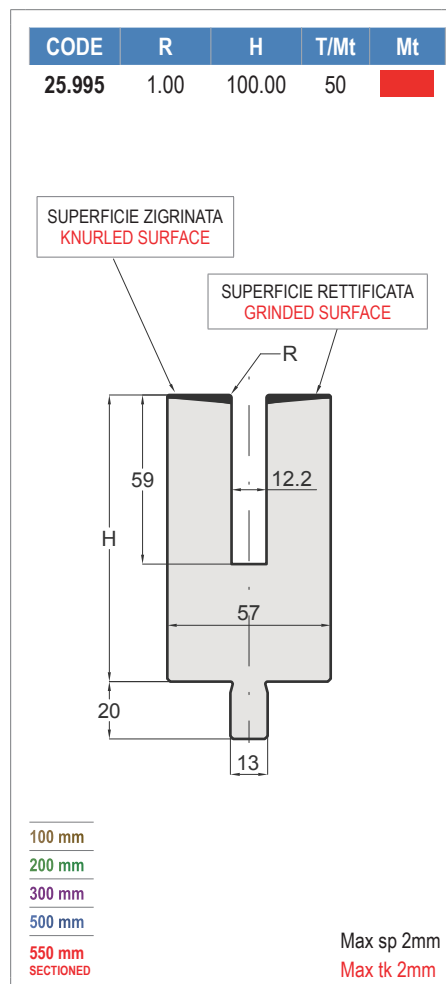
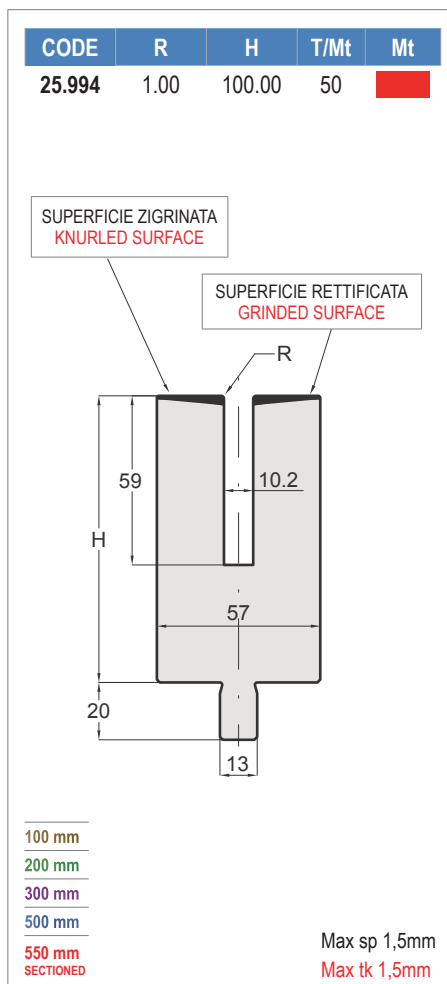
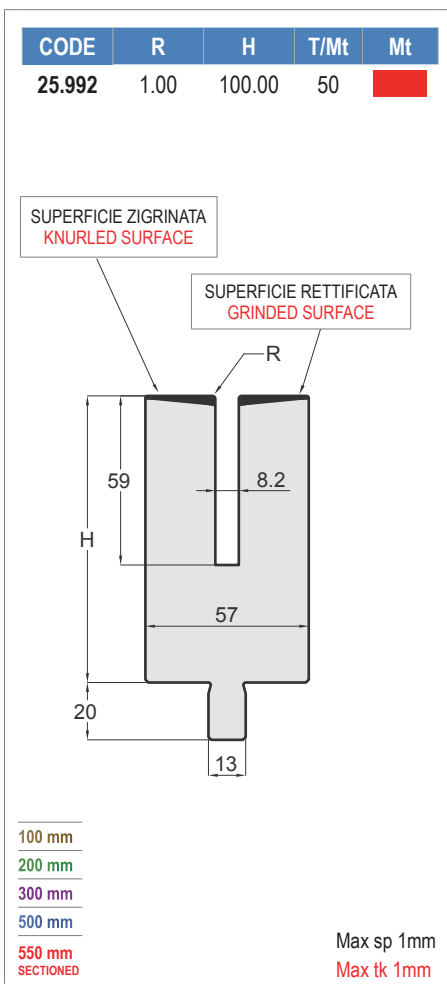
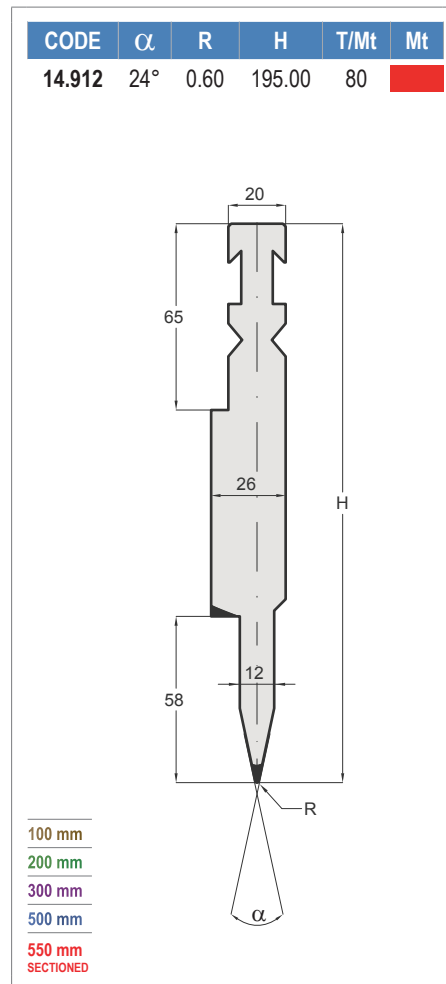
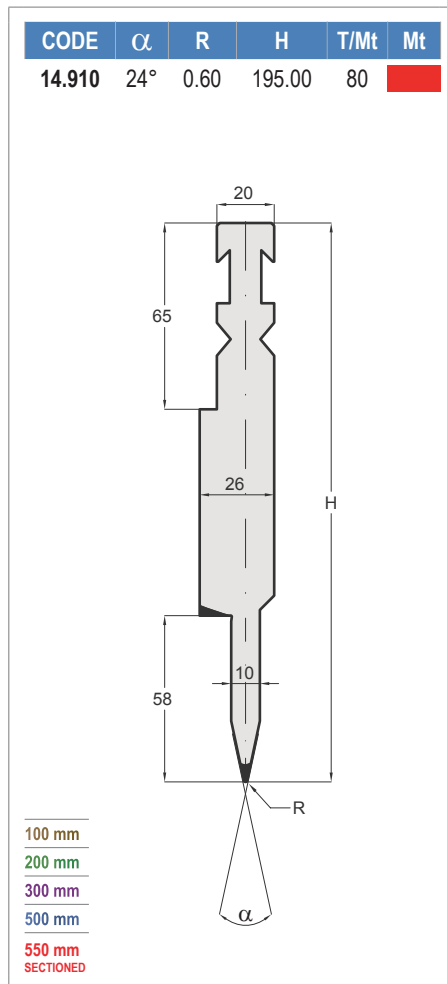
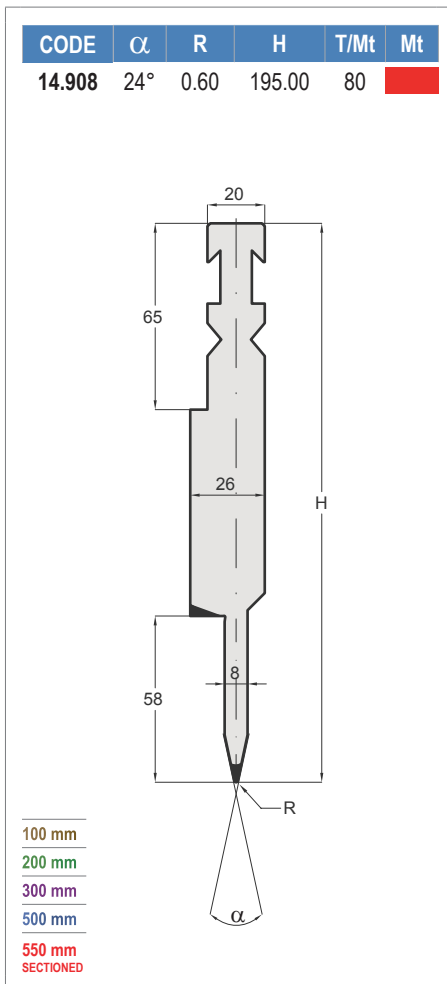



**LVD STYLE**

**PUNZONI**

**PUNCHES**

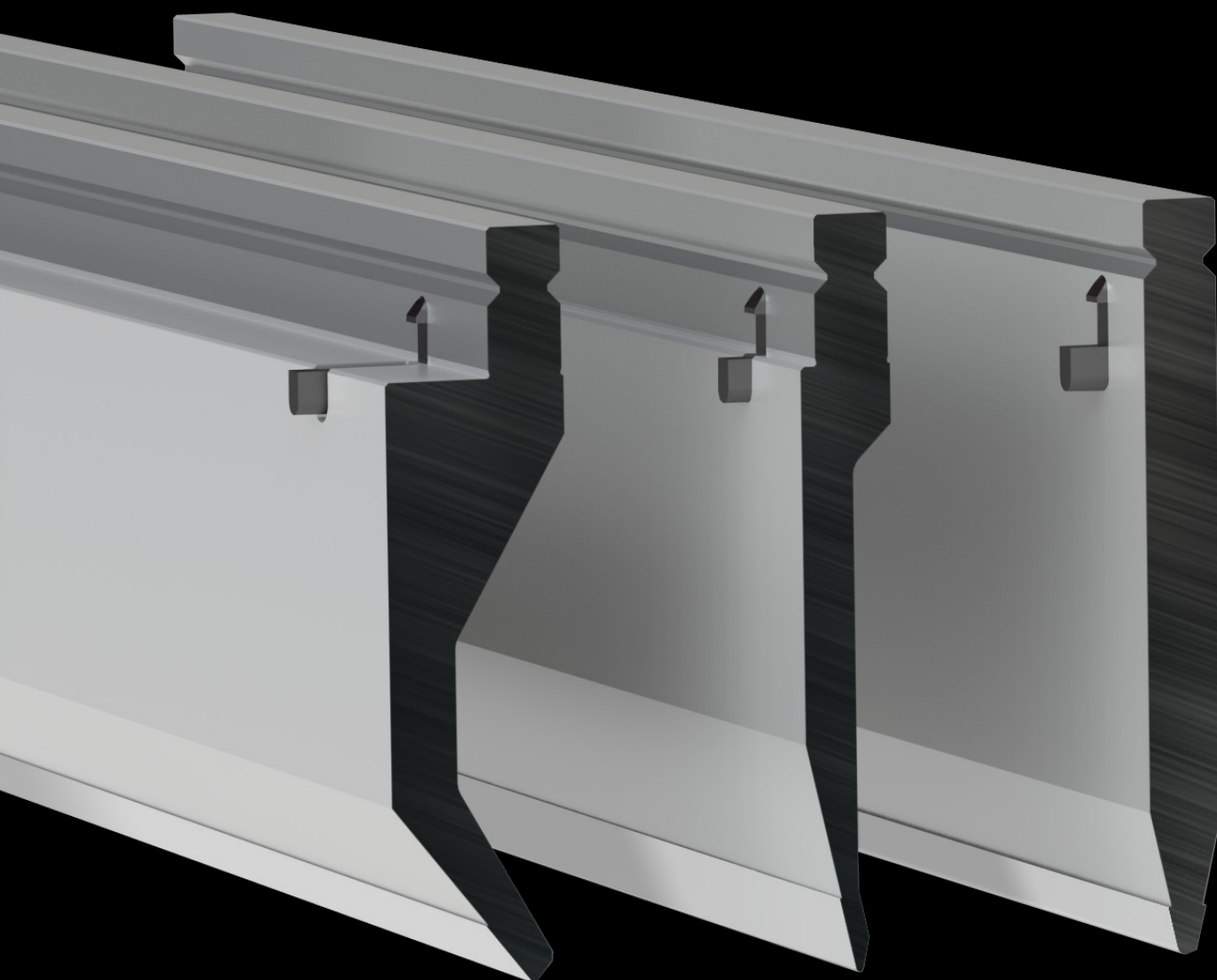

**BLACK LINE**

*LVD STYLE*



# PUNZONI / PUNCHES LVD STYLE

I PUNZONI STANDARD SONO DISPONIBILI A MAGAZZINO NELLE LUNGHEZZE DI: 510 mm E FRAZIONATI (550 mm)  
 THE PUNCHES ARE AVAILABLE IN THE FOLLOWING STANDARD LENGTHS: 510 mm AND SECTIONED (550 mm)

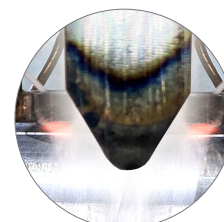
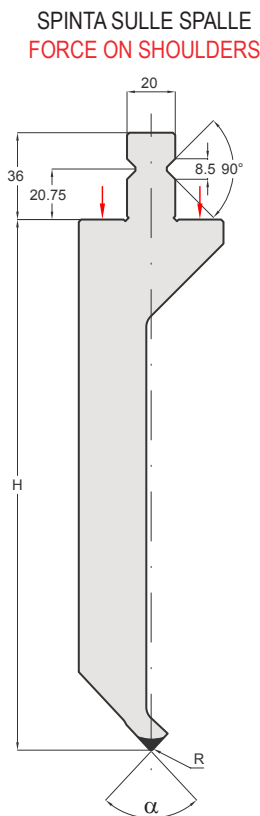
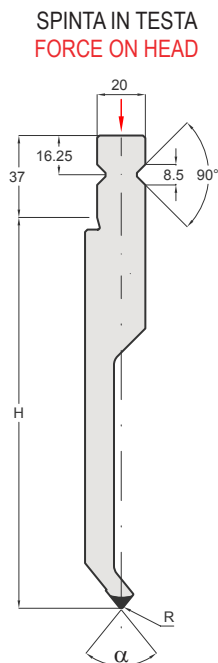

TEMPRA AD INDUZIONE 52-55 HRC  
INDUCTION HARDENED 52-55 HRC

LEGENDA	$\alpha$ = ANGOLO	R = RAGGIO	H = ALTEZZA
LEGEND	$\alpha$ = ANGLE	R = RADIUS	H = HEIGHT

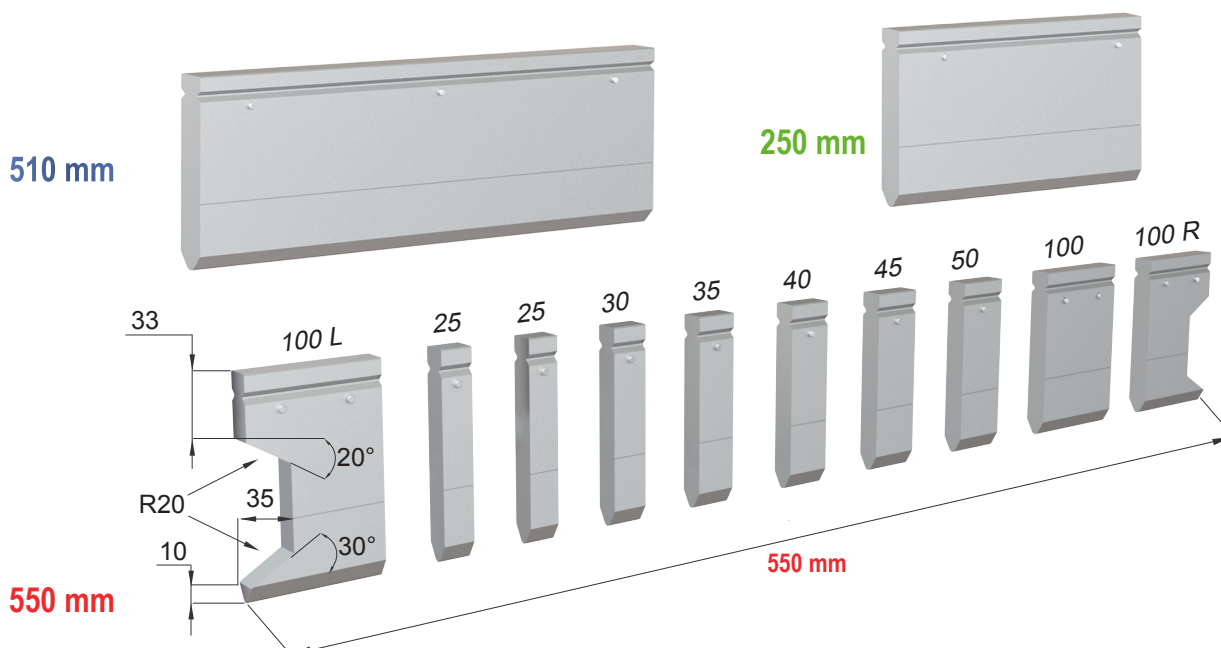
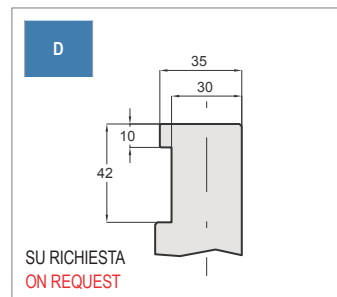
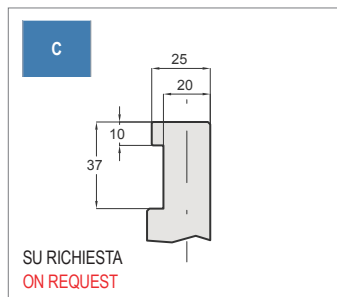
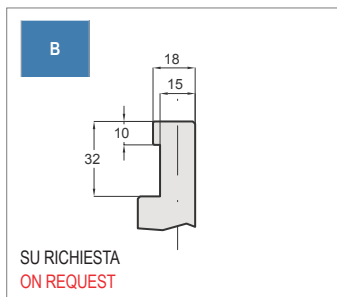
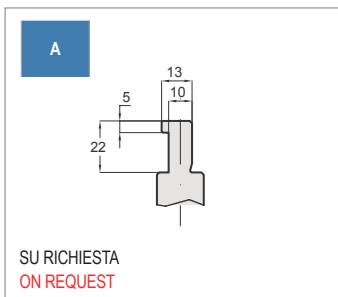

IL CARICO MASSIMO DELLE SCARPETTE CORRISPONDE AL 50% DEL CARICO MASSIMO INDICATO SUL PUNZONE.  
 THE MAX LOAD OF THE HORN EXTENSIONS IS 50% OF THE MAX LOAD OF THE PUNCH.



# PUNZONI / PUNCHES LVD STYLE 26° / 78°

MONTAGGIO E SMONTAGGIO LATERALE DEGLI UTENSILI  
SIDE INSTALLATION AND DISINSTALLATION OF TOOLS

SPINTA IN TESTA  
FORCE ON HEAD



SPINTA SULLE SPALLE  
FORCE ON SHOULDERS

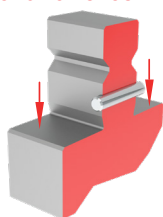

CODE

70.130



SPARE PARTS

CODE

70.150

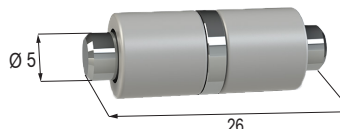

Pag.160

I PUNZONI POSSONO ESSERE FORNITI CON SPINA ROTANTE SU CUSCINETTI - SOLO SU RICHIESTA

PUNCHES CAN BE SUPPLIED WITH ROLL PIN ON BEARINGS - ONLY ON REQUEST

MONTAGGIO E SMONTAGGIO FRONTALE DEGLI UTENSILI  
FRONT INSTALLATION AND DISINSTALLATION OF TOOLS

SPINTA IN TESTA  
FORCE ON HEAD

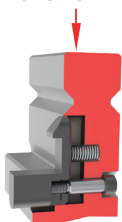

SPINTA SULLE SPALLE  
FORCE ON SHOULDERS

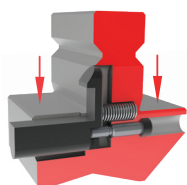

SOLO PER STAMPI FINO ≤ 12,5 KG  
ONLY FOR TOOLS ≤ 12,5 KG

70.714



16.204 16.209

-11-

70.715



16.201 16.202 16.203

16.206 16.207 16.208

-14-

70.716



16.808 16.810 16.812

16.908 16.910 16.912

19

70.718

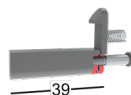

16.200 16.205

39

CODE	α	R	H	T/Mt	Mt
16.200	78°	1.00	159.00	40	

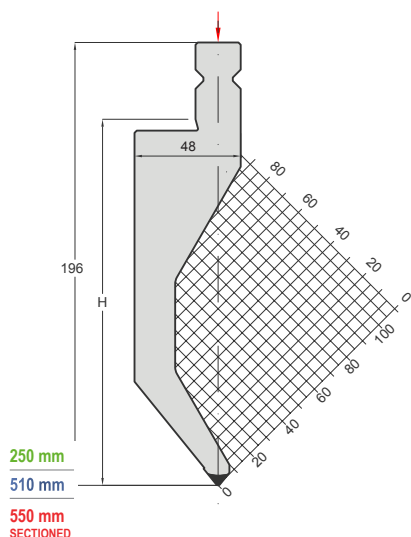

CODE	α	R	H	T/Mt	Mt
16.201	78°	1.00	159.00	40	

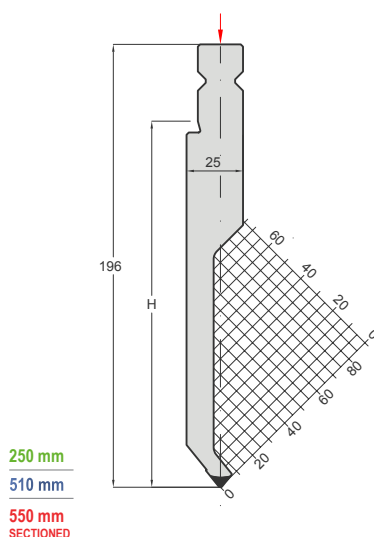

CODE	α	R	H	T/Mt	Mt
16.202	26°	1.00	159.00	40	

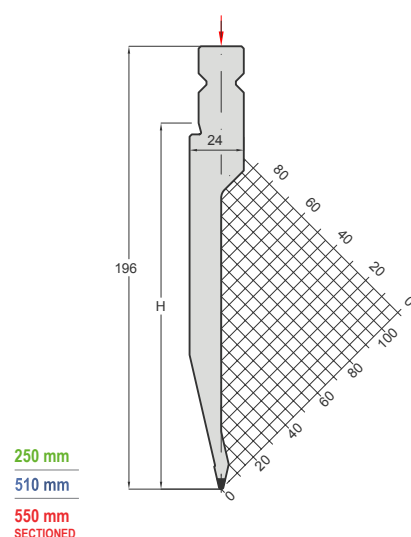

# PUNZONI / PUNCHES LVD STYLE 26° / 78°

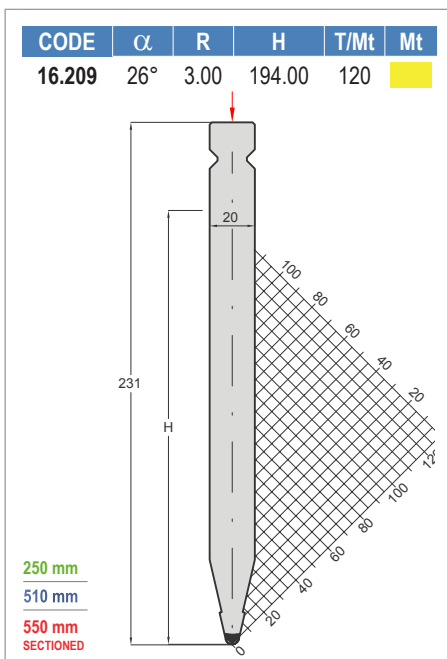
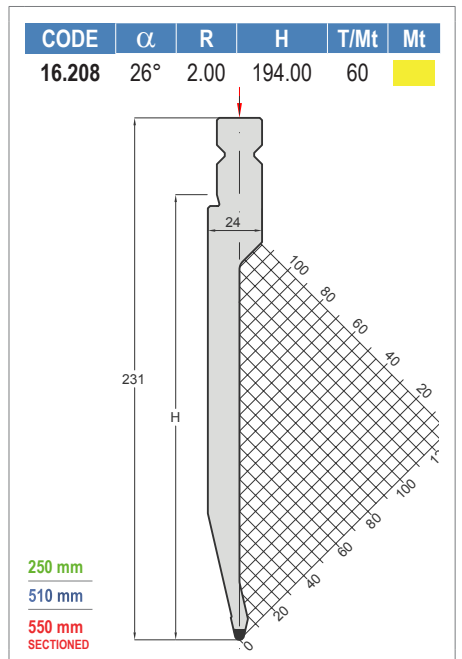
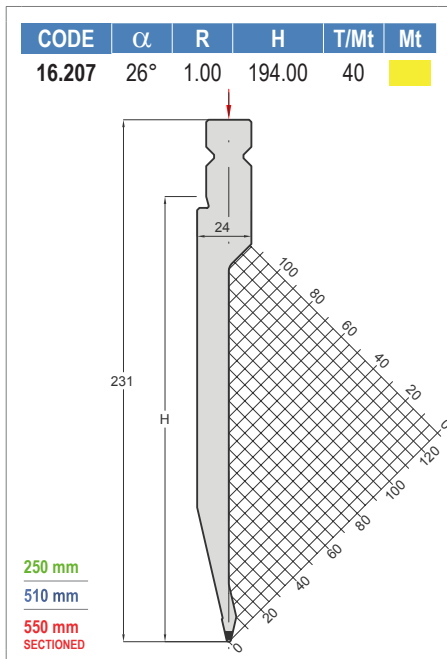
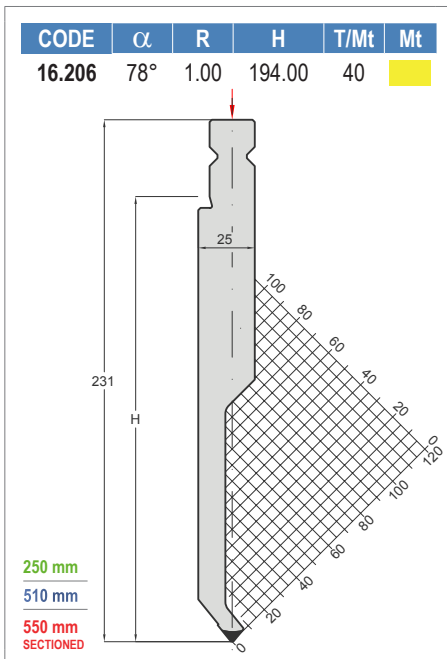
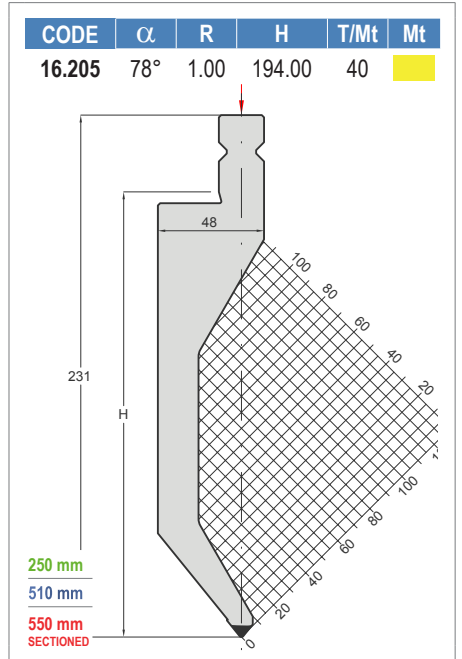
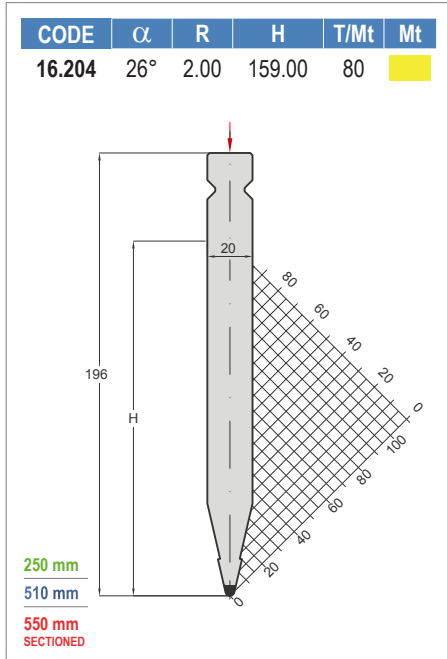
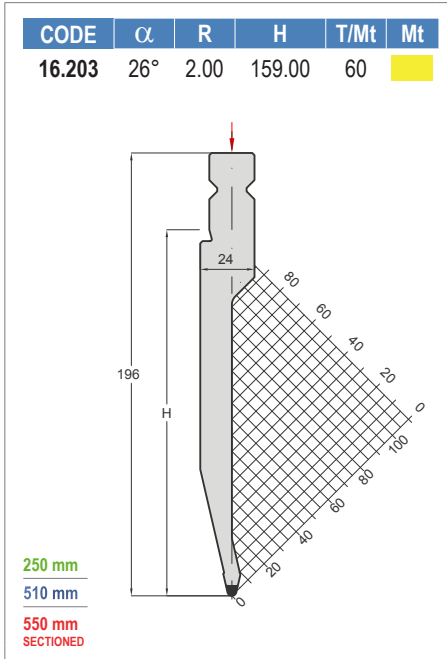

# LVD STYLE

## MATRICI

## DIES

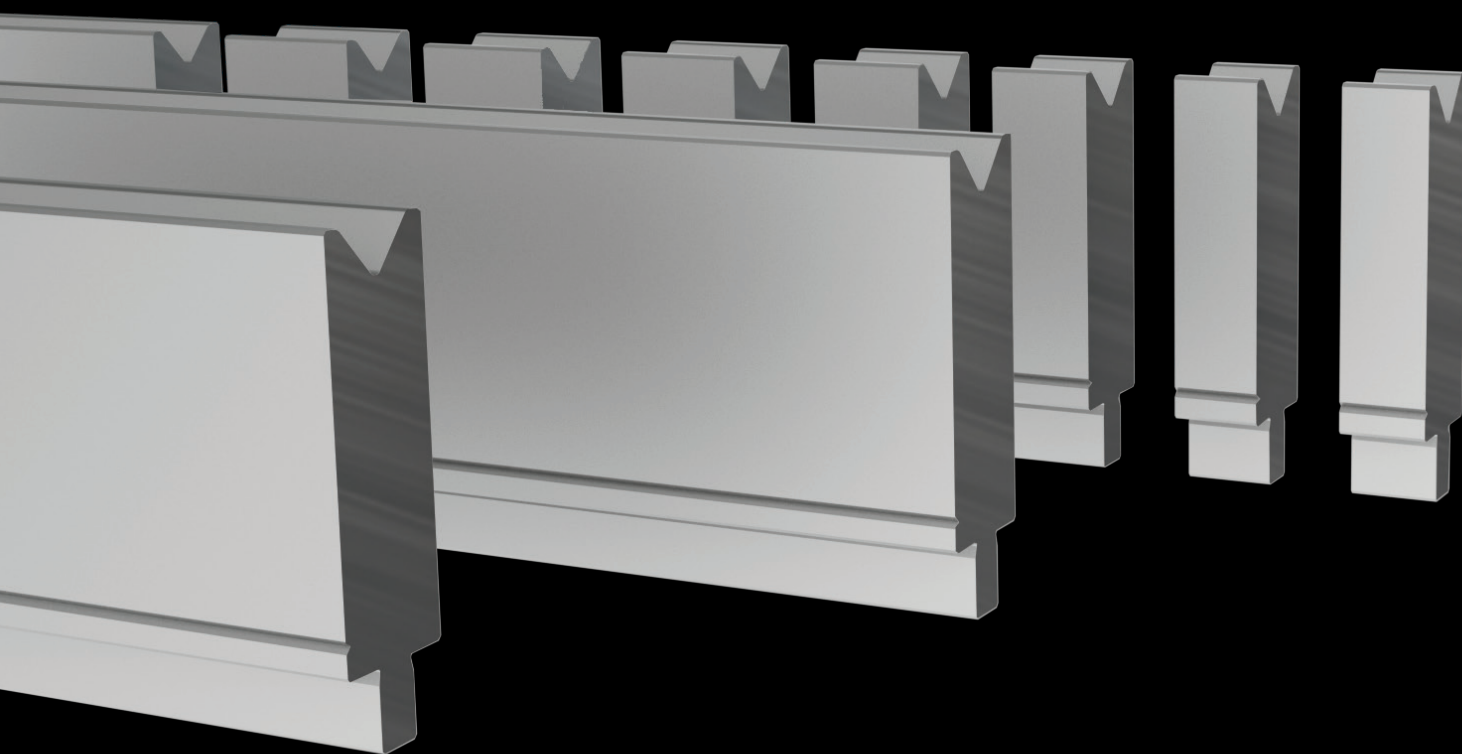

# BLACK LINE

LVD STYLE



# MATRICI / DIES LVD STYLE

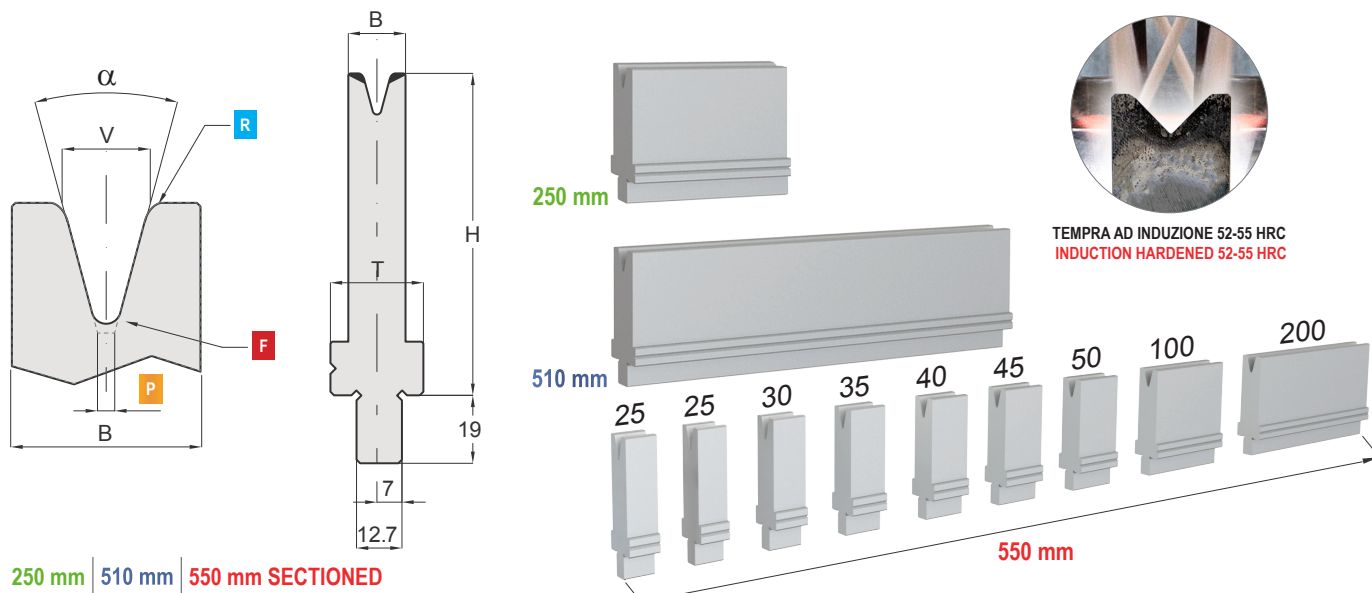

250 mm | 510 mm | 550 mm SECTIONED

LE MATRICI STANDARD SONO DISPONIBILI A MAGAZZINO NELLE LUNGHEZZE DI: 510 mm E FRAZIONATI (550 mm)  
 THE DIES ARE AVAILABLE IN THE FOLLOWING STANDARD LENGTHS: 510 mm AND SECTIONED (550 mm)

<b>LEGENDA</b>	$\alpha$ = ANGOLO	V = AMPIEZZA CAVA	R = RAGGIO	H = ALTEZZA	B = STELO	T = BASE	F = FONDO MATRICE	P = PIANO
<b>LEGEND</b>	$\alpha$ = ANGLE	V = DIE OPENING	R = RADIUS	H = HEIGHT	B = BODY	T = BASE	F = BOTTOM DIES	P = FLAT

CODE	$\alpha$	V	B	T	R	H	F	T/mt	Mt	CODE	$\alpha$	V	B	T	R	H	F	T/mt	Mt
26.200	30°	6	14	26	0.80	90	R1.0	25	■	26.251	30°	8	16	26	0.80	130	R1.2	26	■
26.201	30°	8	16	26	0.80	90	R1.2	26	■	26.252	30°	10	22	26	1.00	130	R1.5	36	■
26.202	30°	10	22	26	1.00	90	R1.5	36	■	26.253	30°	12	26	26	1.20	130	R2.0	46	■
26.203	30°	12	26	26	1.20	90	R2.0	46	■	26.254	30°	16	30	30	1.60	130	R2.5	51	■
26.204	30°	16	30	30	1.60	90	R2.5	51	■	26.255	30°	20	40	40	2.00	130	R3.0	68	■
26.205	30°	20	40	40	2.00	90	R3.0	68	■	26.256	30°	24	46	46	2.40	130	R5.0	93	■
26.206	30°	24	46	46	2.40	90	R5.0	93	■	26.257	30°	30	56	56	3.00	130	R5.0	110	■
26.207	30°	30	56	56	3.00	90	R5.0	110	■	26.258	30°	40	75	75	4.00	130	R7.0	140	■
26.208	30°	40	75	75	4.00	90	R7.0	140	■	26.259	30°	50	90	90	4.00	130	R10	170	■
26.209	30°	50	90	90	4.00	90	R10	135	■	26.260	30°	60	95	95	5.00	130	R13	155	■
26.211	78°	6	10	26	0.80	90	R0.8	28	■	26.262	78°	6	10	26	0.80	130	R0.8	28	■
26.212	78°	8	12	26	0.80	90	R1.2	32	■	26.263	78°	8	12	26	0.80	130	R1.2	32	■
26.213	78°	10	14	26	1.00	90	R1.5	36	■	26.264	78°	10	14	26	1.00	130	R1.5	36	■
26.214	78°	12	18	26	1.20	90	R2.0	50	■	26.265	78°	12	18	26	1.20	130	R2.0	50	■
26.215	78°	16	25	25	1.60	90	R2.5	70	■	26.266	78°	16	25	25	1.60	130	R2.5	70	■
26.216	78°	20	30	30	2.00	90	R3.0	75	■	26.267	78°	20	30	30	2.00	130	R3.0	75	■
26.217	78°	24	32	32	2.40	90	R4.0	91	■	26.268	78°	24	32	32	2.40	130	R4.0	91	■
26.218	78°	30	40	40	3.00	90	R5.0	115	■	26.269	78°	30	40	40	3.00	130	R5.0	115	■
26.219	78°	40	50	50	4.00	90	R8.0	135	■	26.270	78°	40	50	50	4.00	130	R8.0	135	■
26.220	78°	50	65	65	4.00	90	R10	180	■	26.271	78°	50	65	65	4.00	130	R10	180	■
26.221	78°	60	75	75	5.00	90	R12	200	■	26.272	78°	60	75	75	5.00	130	R12	200	■
26.222	78°	80	95	95	6.00	90	R16	230	■	26.273	78°	80	95	95	6.00	130	R16	230	■
26.223	78°	100	125	125	6.00	90	R20	250	■	26.274	78°	100	125	125	6.00	130	R20	340	■
26.250	30°	6	14	26	0.80	130	R1.0	25	■	26.275	78°	120	140	140	6.00	130	R25	270	■

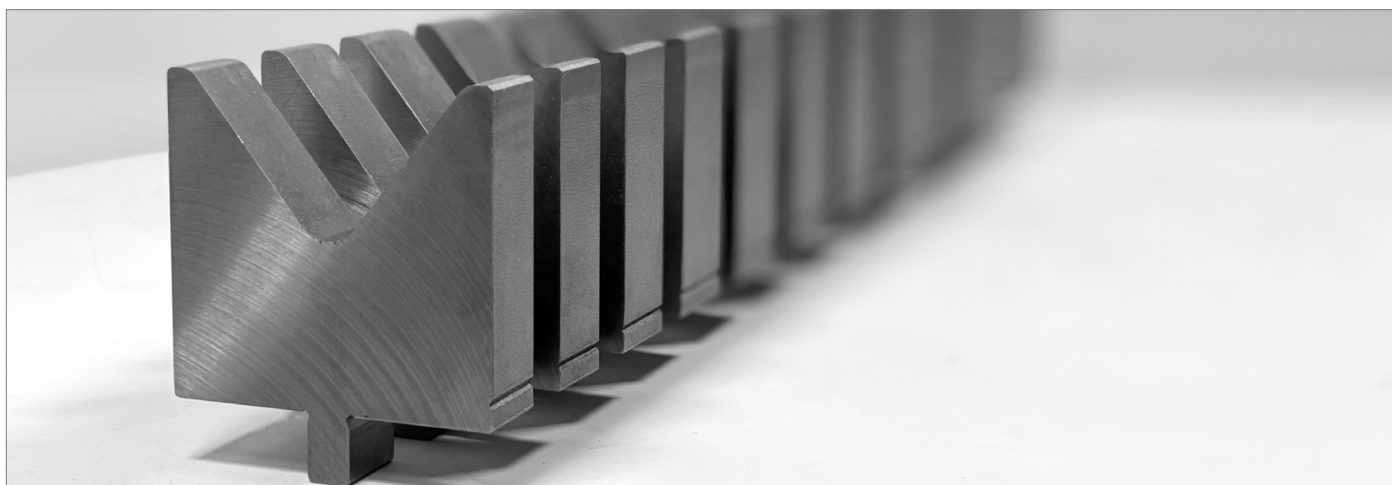

# LVD STYLE PIEGASCHIACCIA HEMMING TOOLS

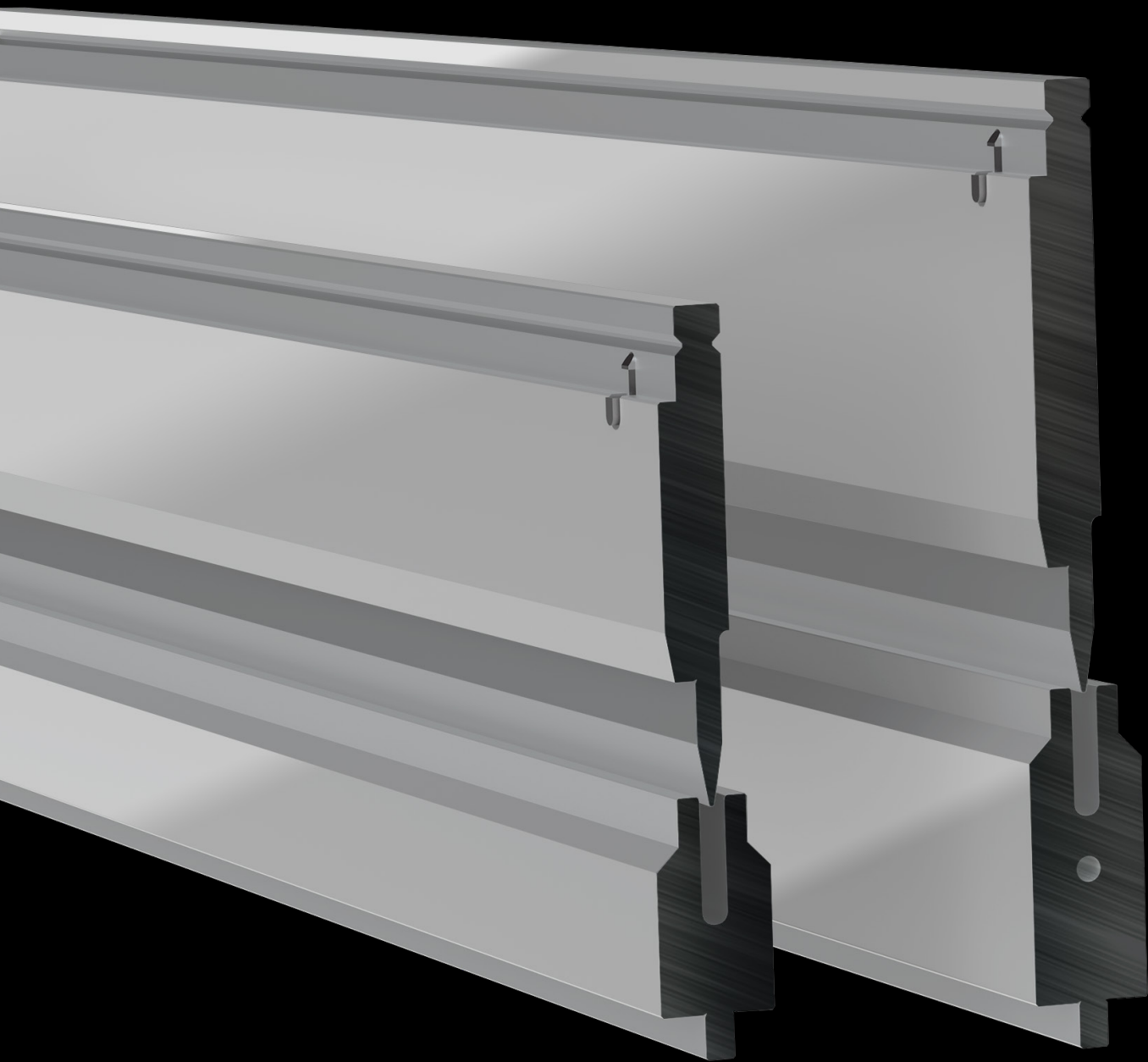

## BLACK LINE

LVD STYLE



# PIEGASCHIACCIA / HEMMING TOOLS LVD STYLE

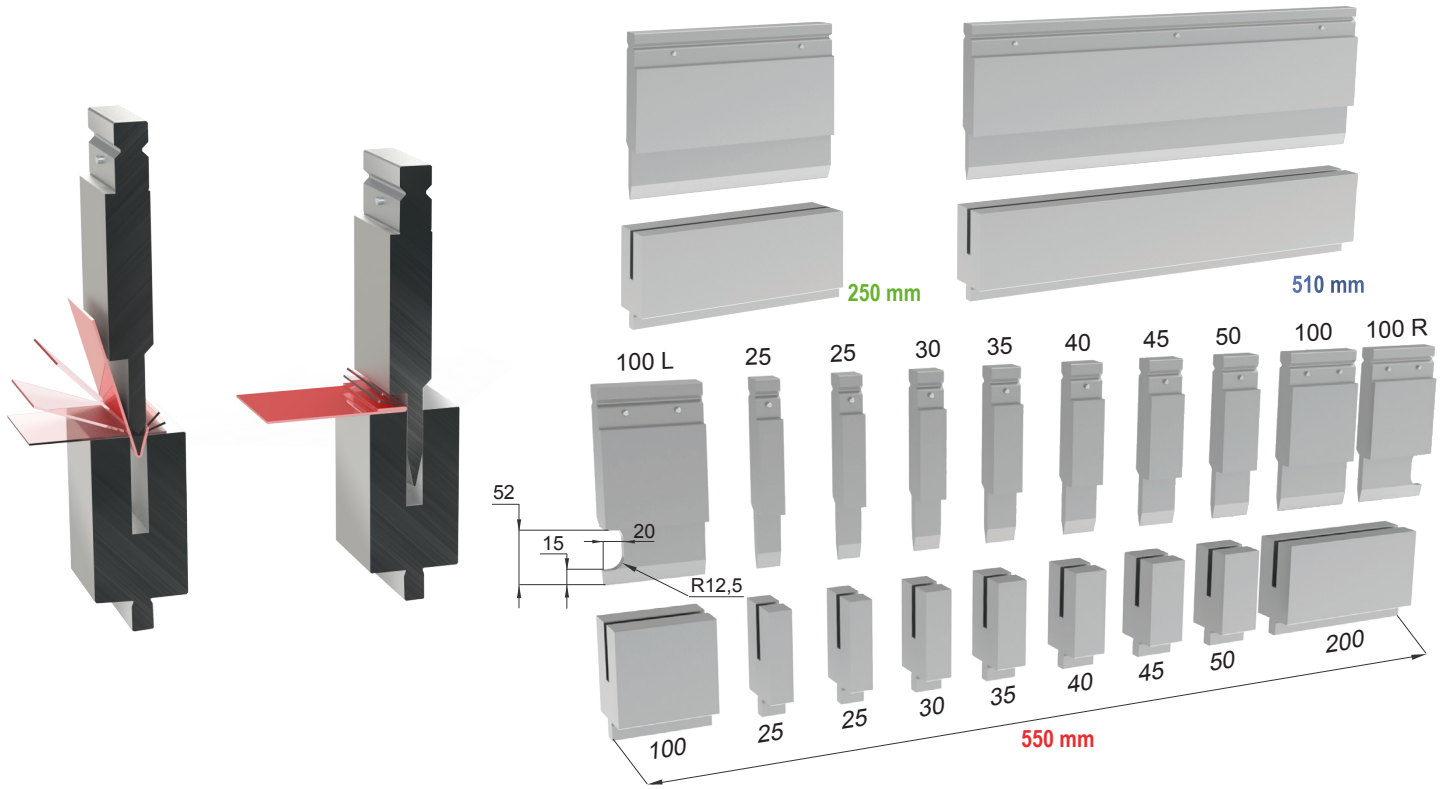

250 mm | 510 mm | 550 mm SECTIONED

IL CARICO MASSIMO DELLE SCARPETTE CORRISPONDE AL 50% DEL CARICO MASSIMO INDICATO SUL PUNZONE.  
 THE MAX LOAD OF THE HORN EXTENSIONS IS 50% OF THE MAX LOAD OF THE PUNCH.

MATERIAL ACC.R ~ 40 Kg/MM <sup>2</sup>					MATERIAL ACC.R ~ 70 Kg/MM <sup>2</sup>										
T		S		2S		S		T		S		2S		S	
S (mm)	(t/m)	T (mm)	(t/m)	2S(mm)	S (mm)	(t/m)	T (mm)	(t/m)	2S(mm)	S (mm)	(t/m)	T (mm)	(t/m)	2S(mm)	S (mm)
0,6	9	3	23	1,2	0,6	15	3	35	1,2	0,6	15	3	35	1,2	0,6
0,8	12	3	32	1,6	0,8	20	3	50	1,6	0,8	20	3	50	1,6	0,8
1,0	15	3,5	40	2,0	1,0	25	3,5	60	2,0	1,0	25	3,5	60	2,0	1,0
1,25	17	3,5	50	2,5	1,25	26	3,5	80	2,5	1,25	26	3,5	80	2,5	1,25
1,5	22	4,6	63	3,0	1,5	38	4,6	95	3,0	1,5	38	4,6	95	3,0	1,5
2,0	30	5,5	80	4,0	2,0	50	5,5	130	4,0	2,0	50	5,5	130	4,0	2,0
2,5	55	6,5	90	5,0											
3,0	70	8,0	100	6,0											

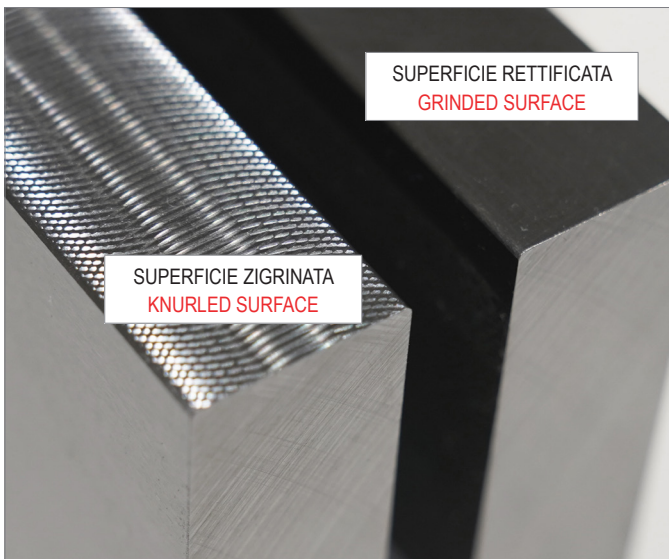

# PIEGASCHIACCIA / HEMMING TOOLS - H=90 LVD STYLE

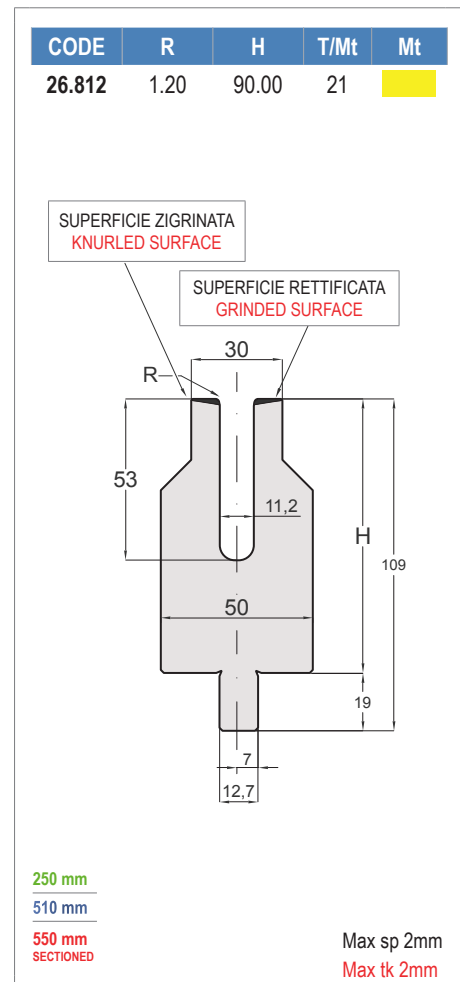
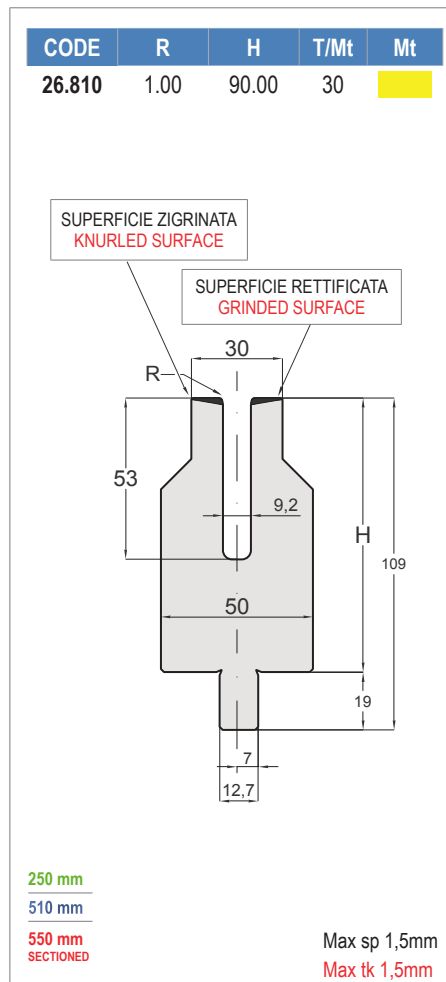
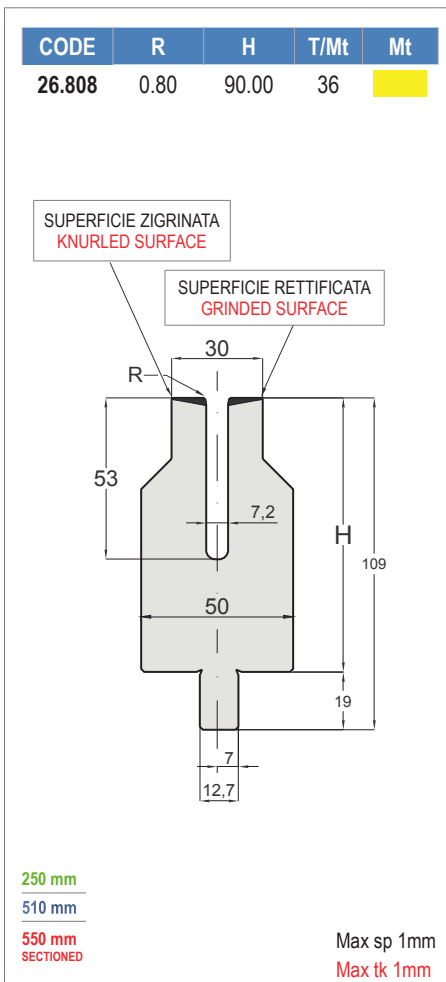
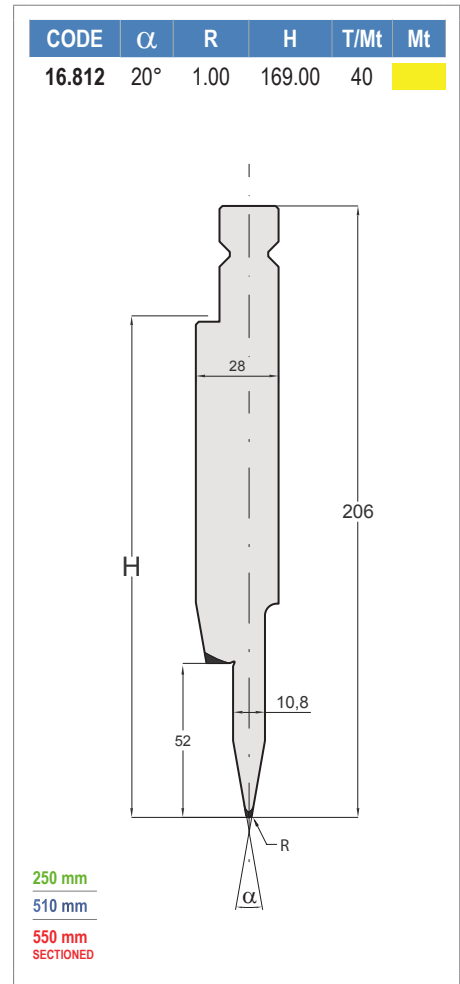
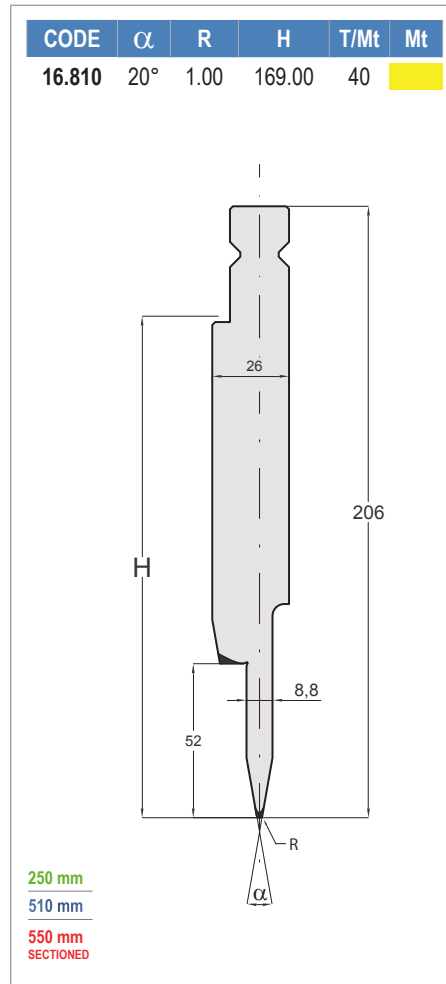
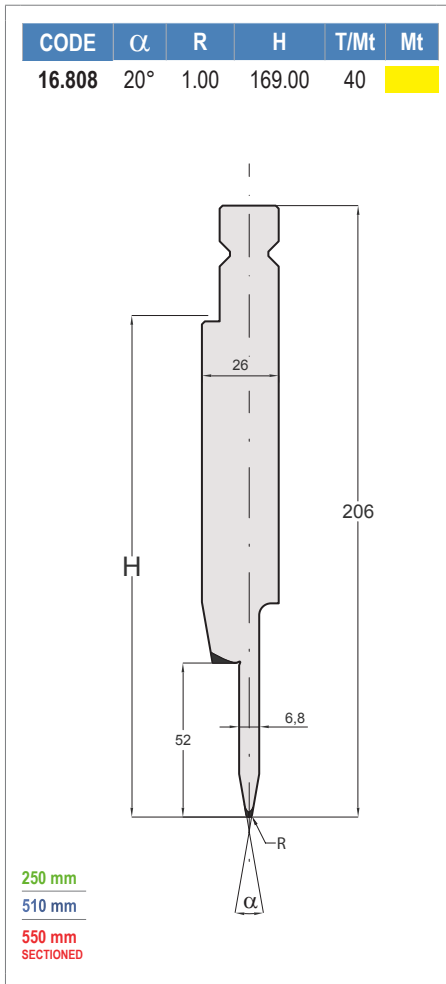

# PIEGASCHIACCIA / HEMMING TOOLS - H=130 LVD STYLE

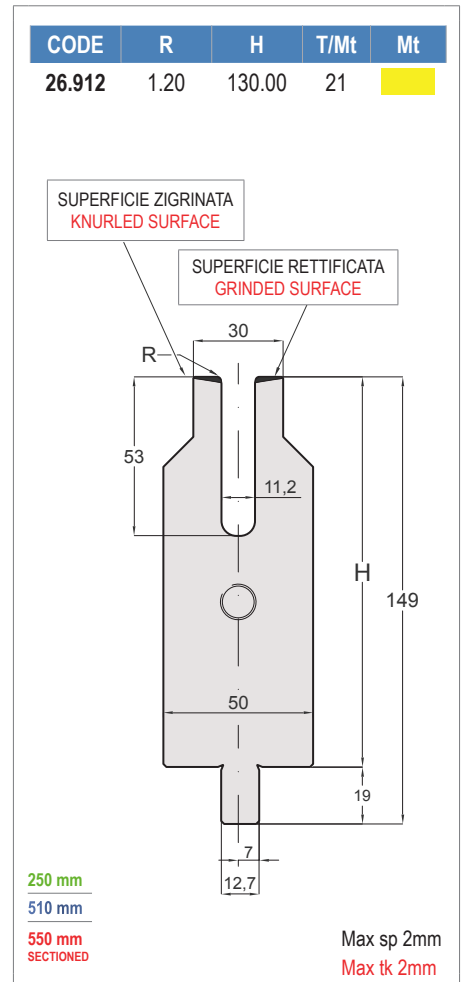
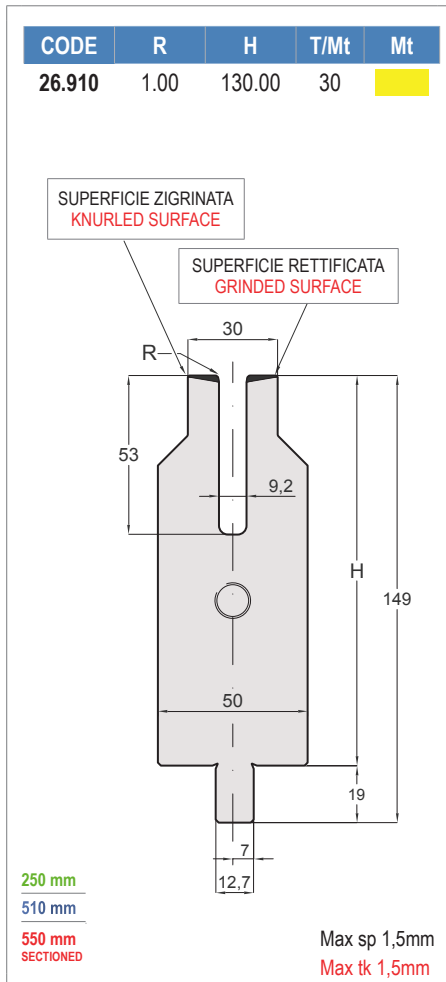
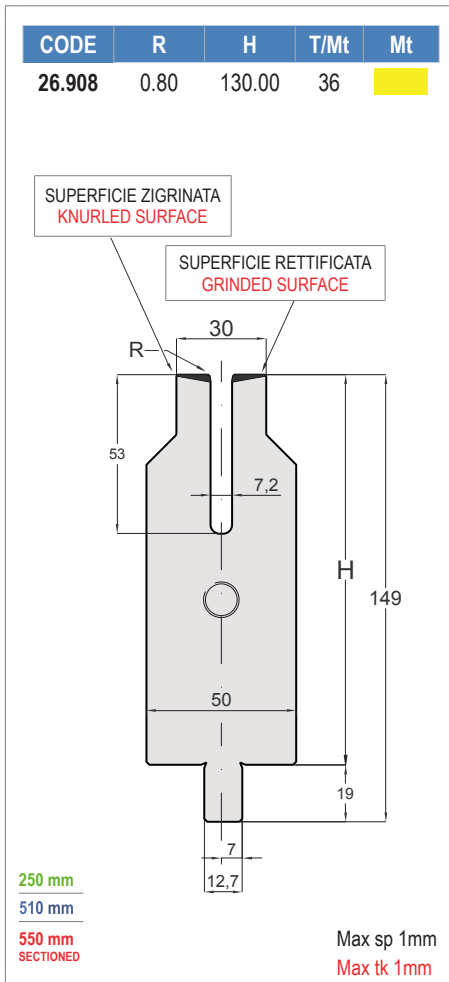
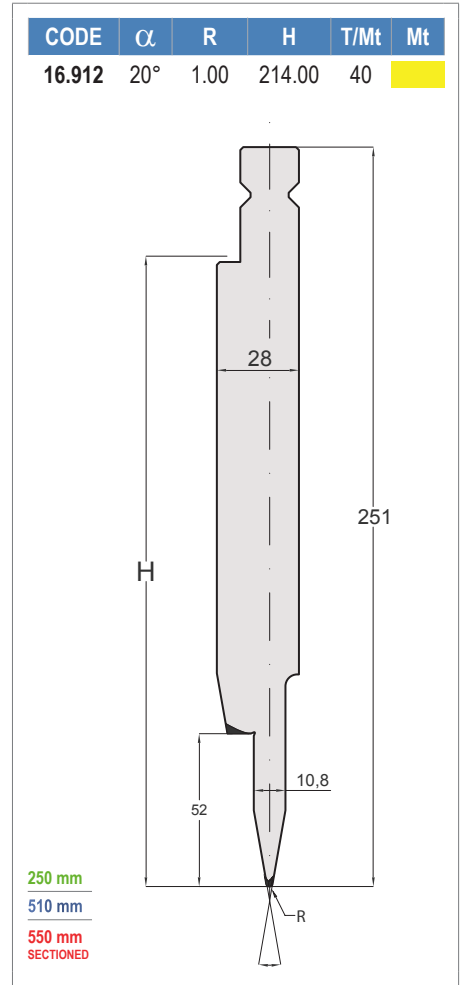
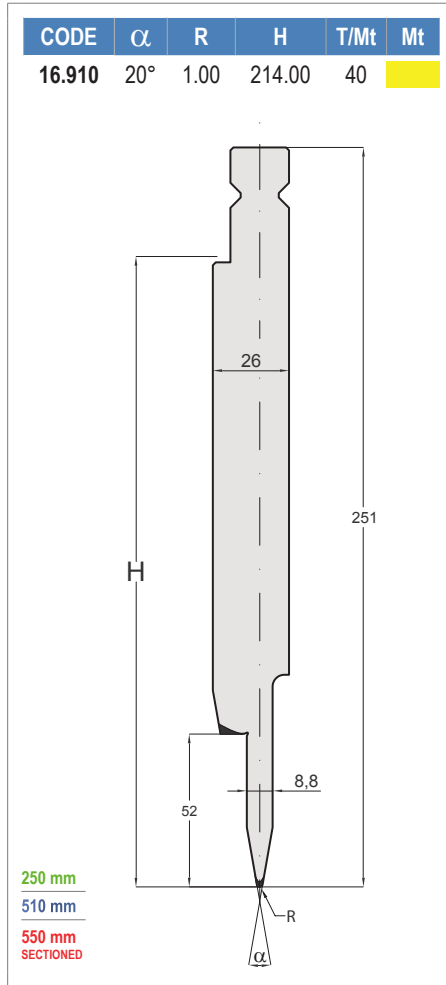
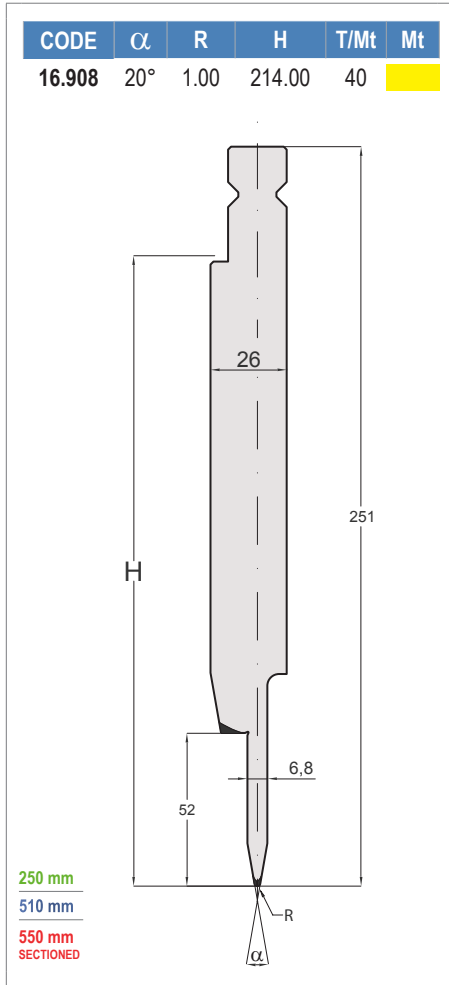



AJIAL - AMERICAN - COLGAR  
COLLY - HÄMMERLE - EHT  
NEWTON - WEINBRENNER STYLE

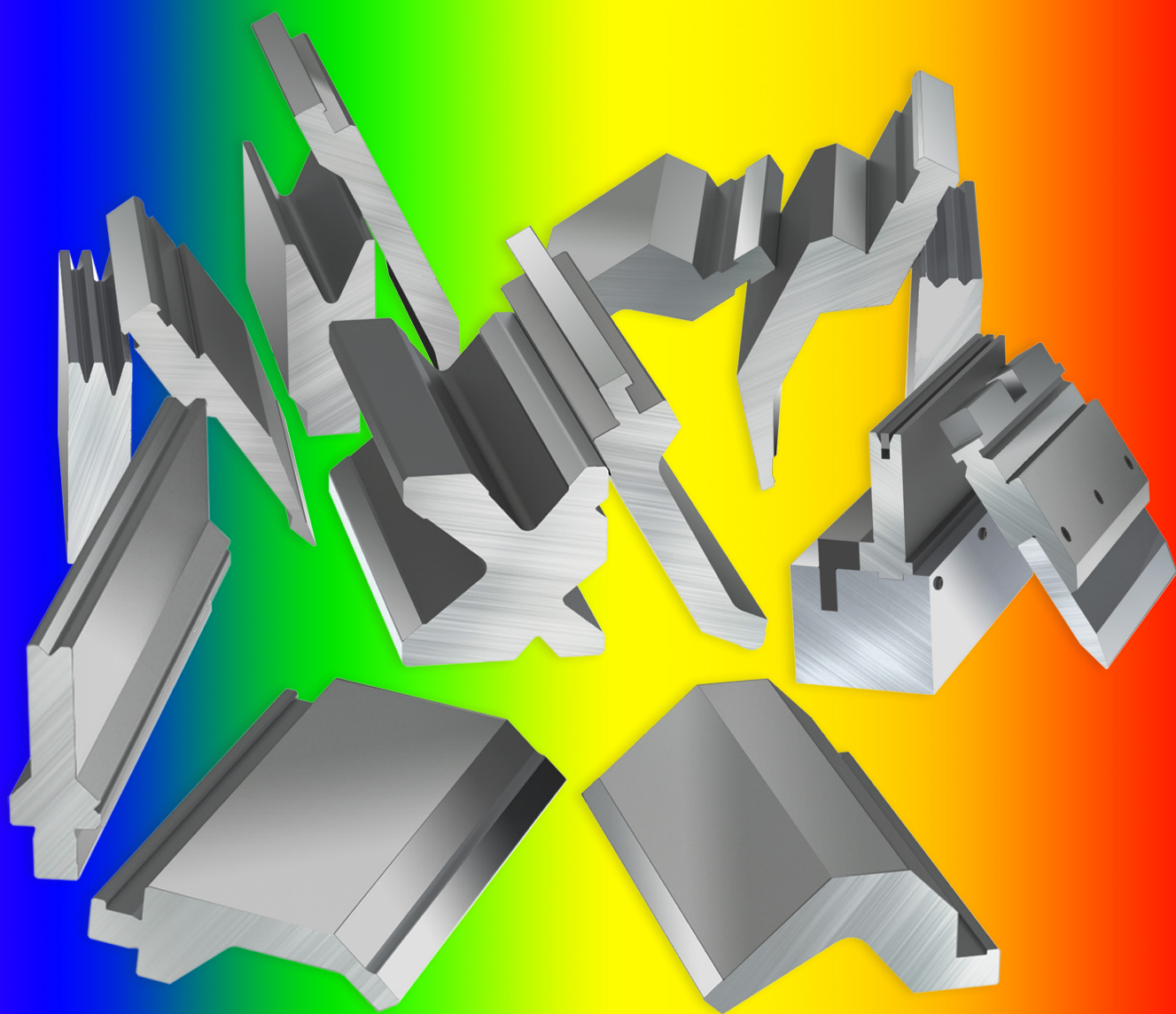

## RAINBOW LINE

UTENSILI MULTIMARCA  
MULTI BRAND TOOLS



# PUNZONI / PUNCHES AJIAL STYLE

I PUNZONI SONO PRODOTTI A RICHIESTA NELLE LUNGHEZZE DI: 1020 mm E FRAZIONATI (990 mm)  
 THE PUNCHES ARE PRODUCED ON REQUEST IN THE FOLLOWING LENGTHS: 1020 mm AND SECTIONED (990 mm)

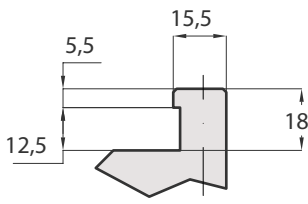

CODE .....  
 H = .....  
 B = .....  
 R = .....  
 α = .....

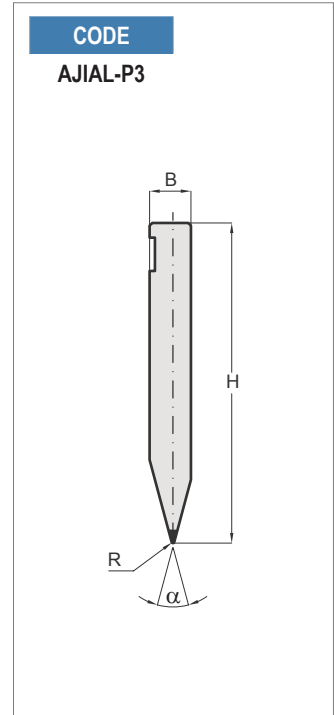
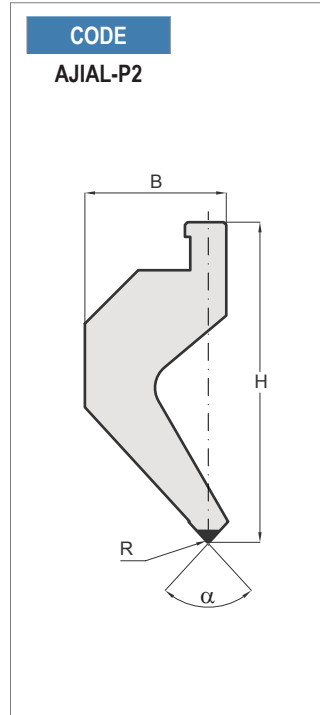
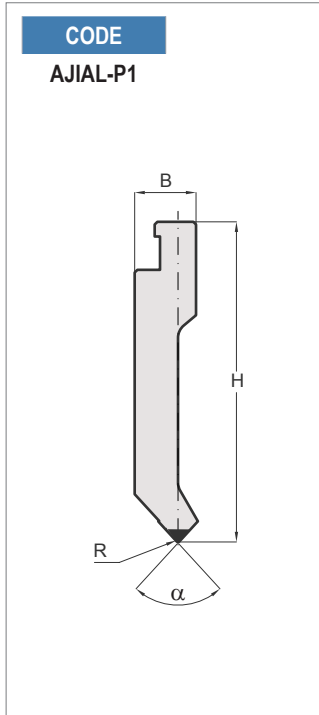

1020 mm | 990 mm SECTIONED

SPECIFICARE DIMENSIONI / SPECIFY DIMENSIONS

# MATRICI / DIES AJIAL STYLE

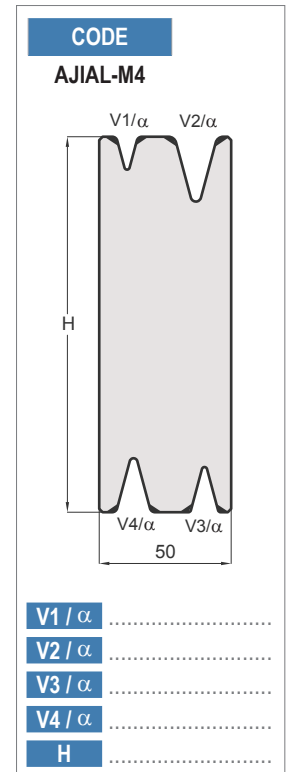
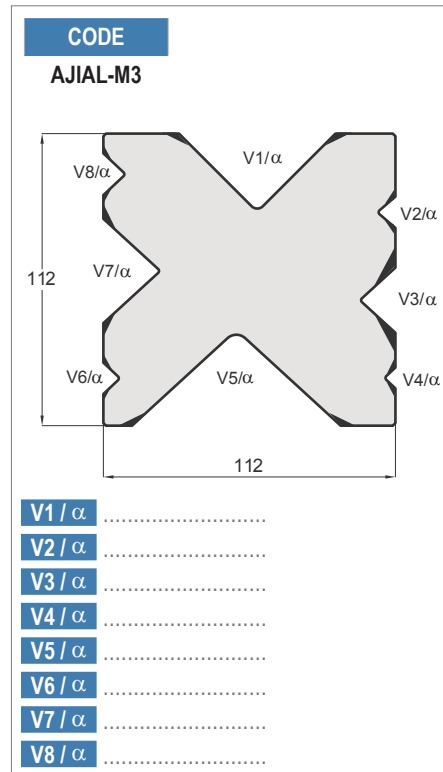
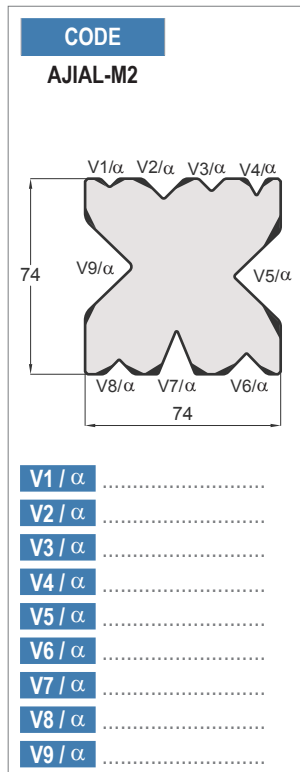
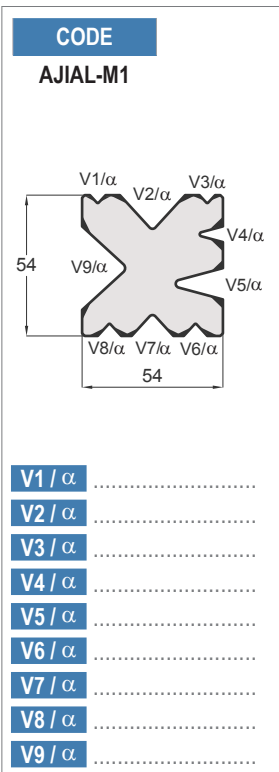

1020 mm | 990 mm SECTIONED

SPECIFICARE DIMENSIONI / SPECIFY DIMENSIONS

# PUNZONI / PUNCHES MATRICI / DIES AMERICAN STYLE

PUNZONI A RICHIESTA NELLE LUNGHEZZE DI: 18" (457.2 mm)  
 PUNCHES ON REQUEST IN THE FOLLOWING LENGTHS: 18" (457.2 mm)

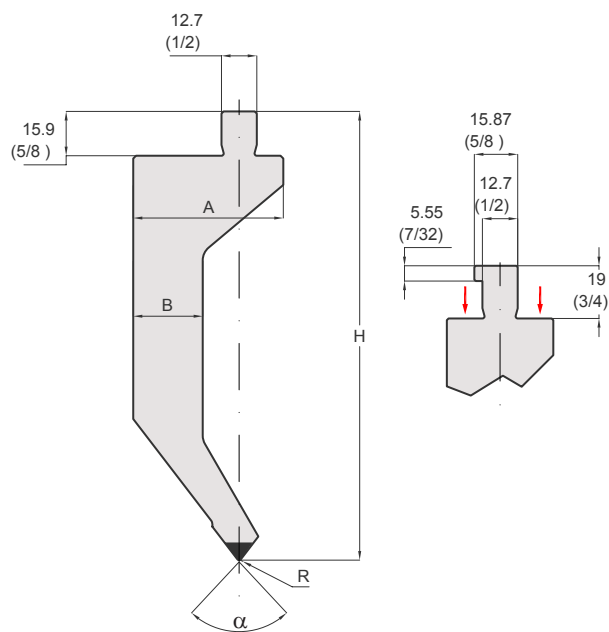

457.2 mm | 18" inches

LEGENDA	$\alpha$ = ANGOLO	R = RAGGIO	H = ALTEZZA
LEGEND	$\alpha$ = ANGLE	R = RADIUS	H = HEIGHT

MATRICI A RICHIESTA NELLE LUNGHEZZE DI: 18" (457.2 mm)  
 DIES ON REQUEST IN THE FOLLOWING LENGTHS: 18" (457.2 mm)

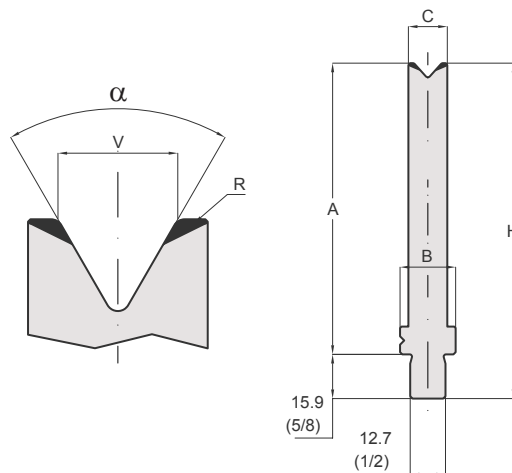

457.2 mm | 18" inches

LEGENDA	$\alpha$ = ANGOLO	R = RAGGIO	H = ALTEZZA
LEGEND	$\alpha$ = ANGLE	R = RADIUS	H = HEIGHT

# ADATTATORI / ADAPTERS AMERICAN STYLE

CODE	L	H	T/Mt	Mt
50.950	150	67.00	100	■

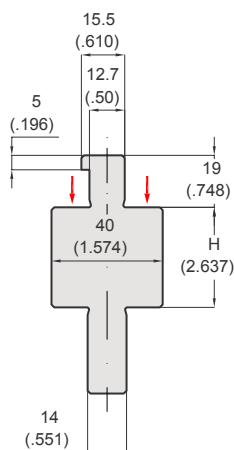

457.2 mm | 18" inches

USA - EU ADAPTER

CODE	L	H	T/Mt	Mt
60.980	835	35.00	100	■

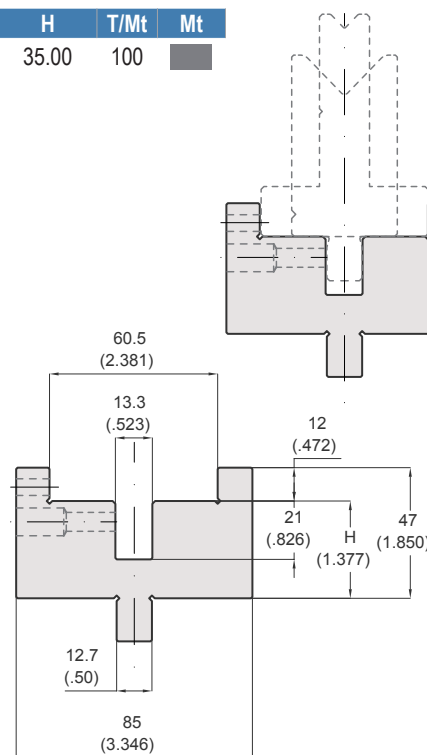

457.2 mm | 18" inches

USA - EU - WILA LOWER ADAPTER

# PUNZONI / PUNCHES COLGAR STYLE

I PUNZONI SONO PRODOTTI A RICHIESTA NELLE LUNGHEZZE DI: 525 mm E FRAZIONATI (495 mm, 500 mm)  
 THE PUNCHES ARE PRODUCED ON REQUEST IN THE FOLLOWING LENGTHS: 525 mm AND SECTIONED (495 mm, 500 mm)

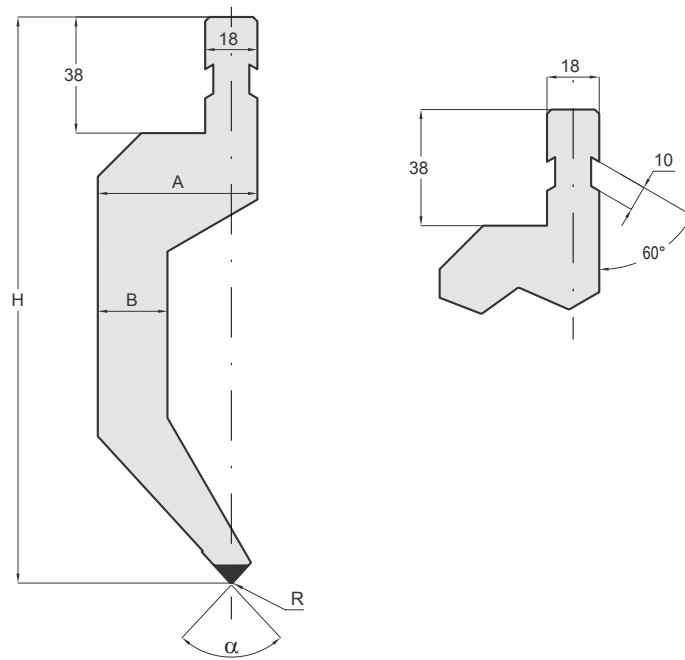

525 mm | 495 mm, 500 mm SECTIONED

LEGENDA	$\alpha$ = ANGOLO	R = RAGGIO	H = ALTEZZA
LEGEND	$\alpha$ = ANGLE	R = RADIUS	H = HEIGHT

## MODELLI SU RICHIESTA / MODELS ON REQUEST

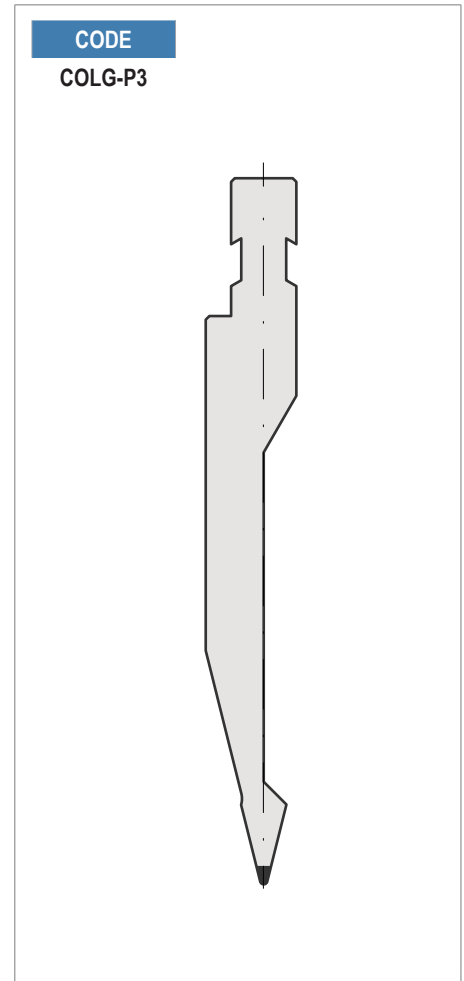
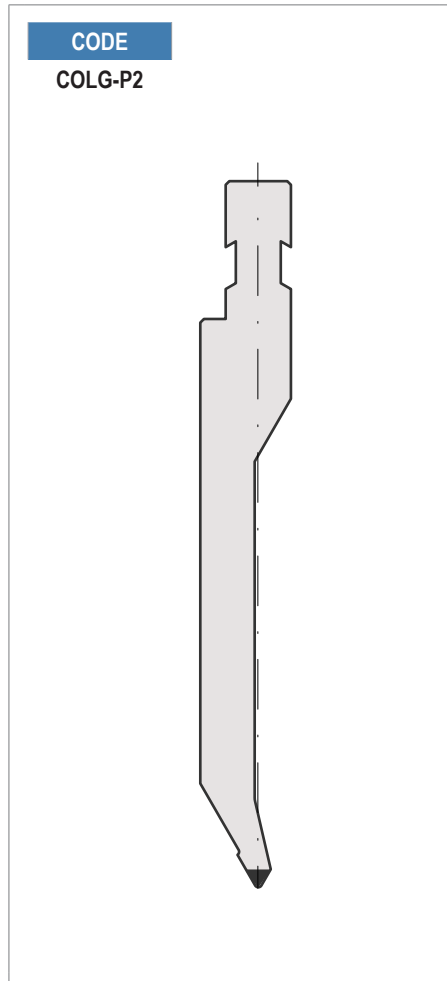
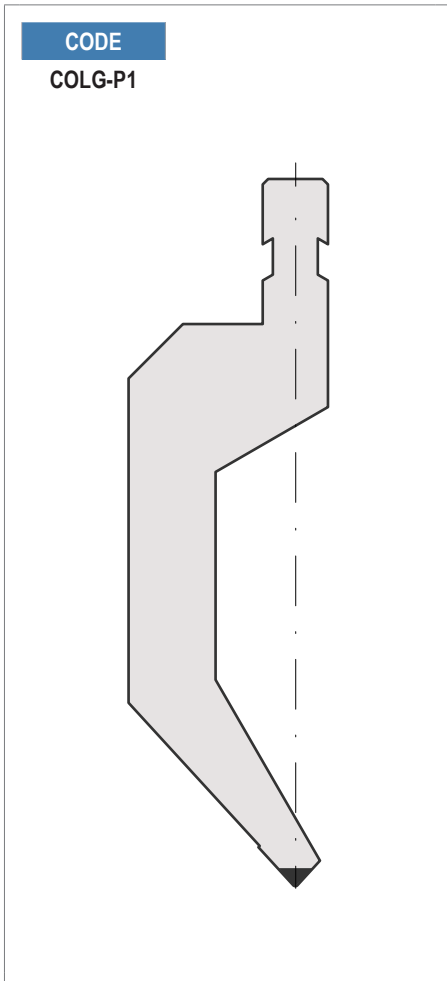

## PUNZONI / PUNCHES COLLY STYLE

I PUNZONI SONO PRODOTTI A RICHIESTA NELLE LUNGHEZZE DI: 1020 mm E FRAZIONATI (1250 mm)  
 THE PUNCHES ARE PRODUCED ON REQUEST IN THE FOLLOWING LENGTHS: 1020 mm AND SECTIONED (1250 mm)

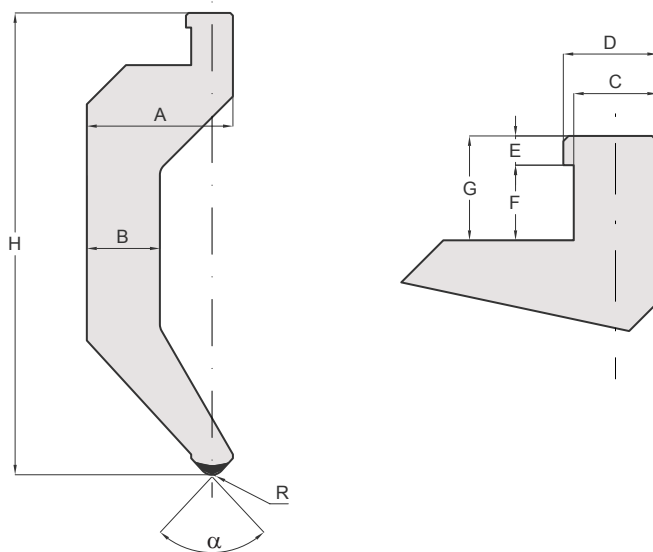

1020 mm | 1250 mm SECTIONED

LEGENDA	$\alpha$ = ANGOLO	R = RAGGIO	H = ALTEZZA
LEGEND	$\alpha$ = ANGLE	R = RADIUS	H = HEIGHT

## MATRICI / DIES COLLY STYLE

LE MATRICI SONO PRODOTTE SU RICHIESTA NELLE LUNGHEZZE DI: 1020 mm E FRAZIONATI (990 mm)  
 THE DIES ARE PRODUCED ON REQUEST IN THE FOLLOWING LENGTHS: 1020 mm AND SECTIONED (990 mm)

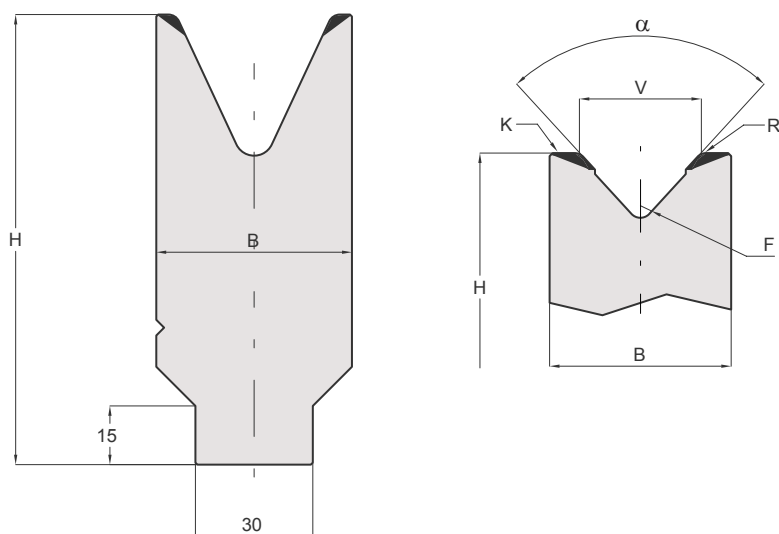

1020 mm | 1250 mm SECTIONED

LEGENDA	$\alpha$ = ANGOLO	V = AMPIEZZA CAVA	R = RAGGIO	H = ALTEZZA	B = STELO	F = FONDO MATRICE
LEGEND	$\alpha$ = ANGLE	V = DIE OPENING	R = RADIUS	H = HEIGHT	B = BODY	F = BOTTOM DIE

# SUPPORTI E LAME / HOLDERS AND BLADES **HÄMMERLE STYLE**

PRODOTTI A RICHIESTA  
PRODUCTS ON REQUEST

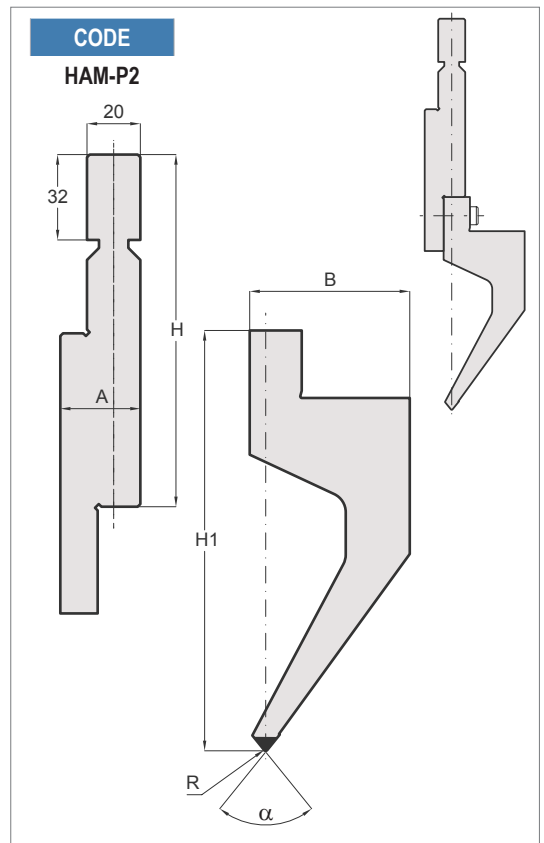
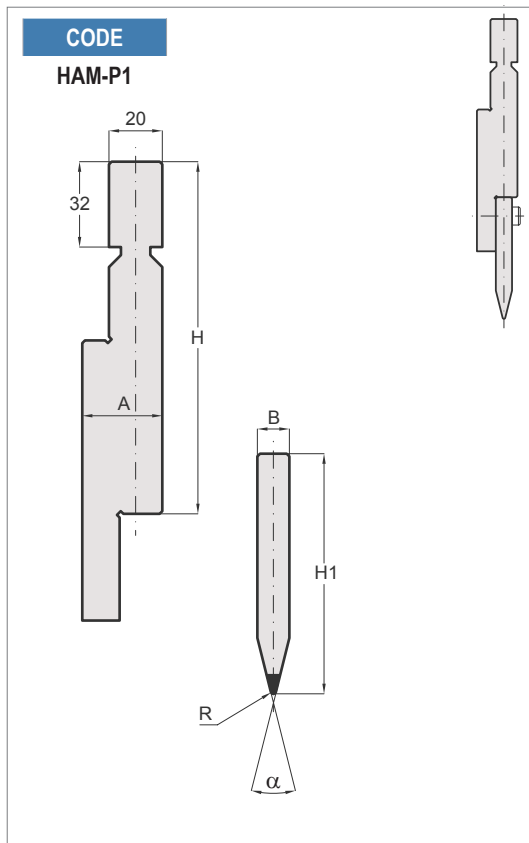

**CODE** .....

**H =** .....

**H1 =** .....

**A =** .....

**B =** .....

**R =** .....

**α =** .....

SPECIFICARE DIMENSIONI / SPECIFY DIMENSIONS

## MATRICI / DIES **HÄMMERLE STYLE**

LE MATRICI SONO PRODOTTE SU RICHIESTA  
THE DIES ARE PRODUCED ON REQUEST

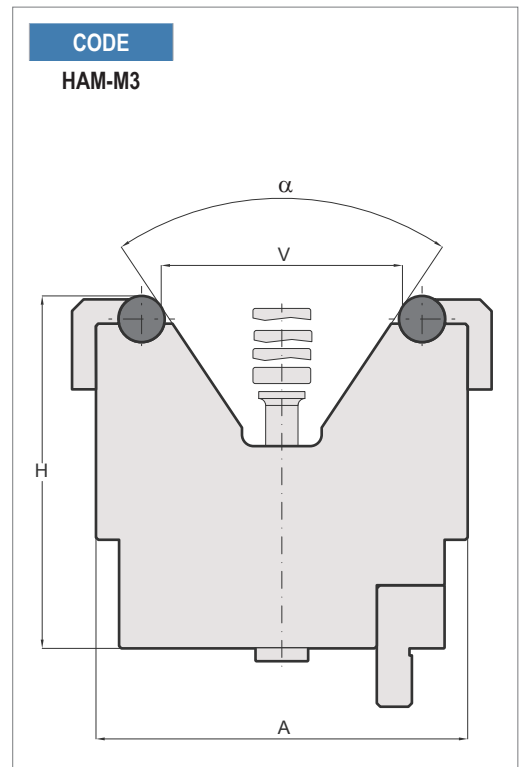
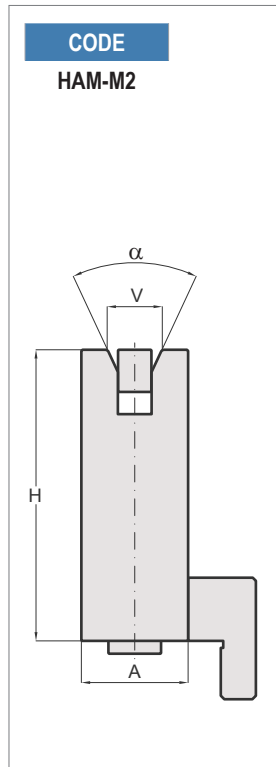
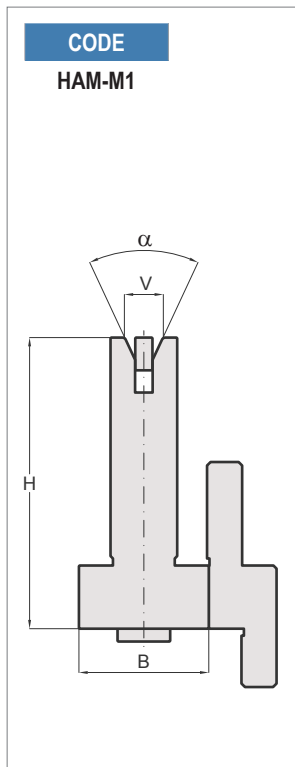

**CODE** .....

**H =** .....

**A =** .....

**B =** .....

**R =** .....

**α =** .....

SPECIFICARE DIMENSIONI / SPECIFY DIMENSIONS

# PUNZONI / PUNCHES EHT STYLE

I PUNZONI SONO PRODOTTI A RICHIESTA NELLE LUNGHEZZE DI: 2100 mm, 2600 mm, 3100 mm, 3600 mm E 4100 mm (FRAZIONATI)

THE PUNCHES ARE PRODUCED ON REQUEST IN THE FOLLOWING LENGTHS: 2100 mm, 2600 mm, 3100 mm, 3600 mm AND 4100 mm (SECTIONED)

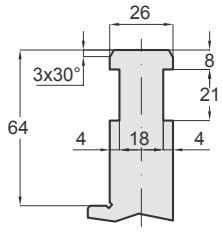

CODE .....  
 H = .....  
 B = .....  
 R = .....  
 $\alpha$  = .....

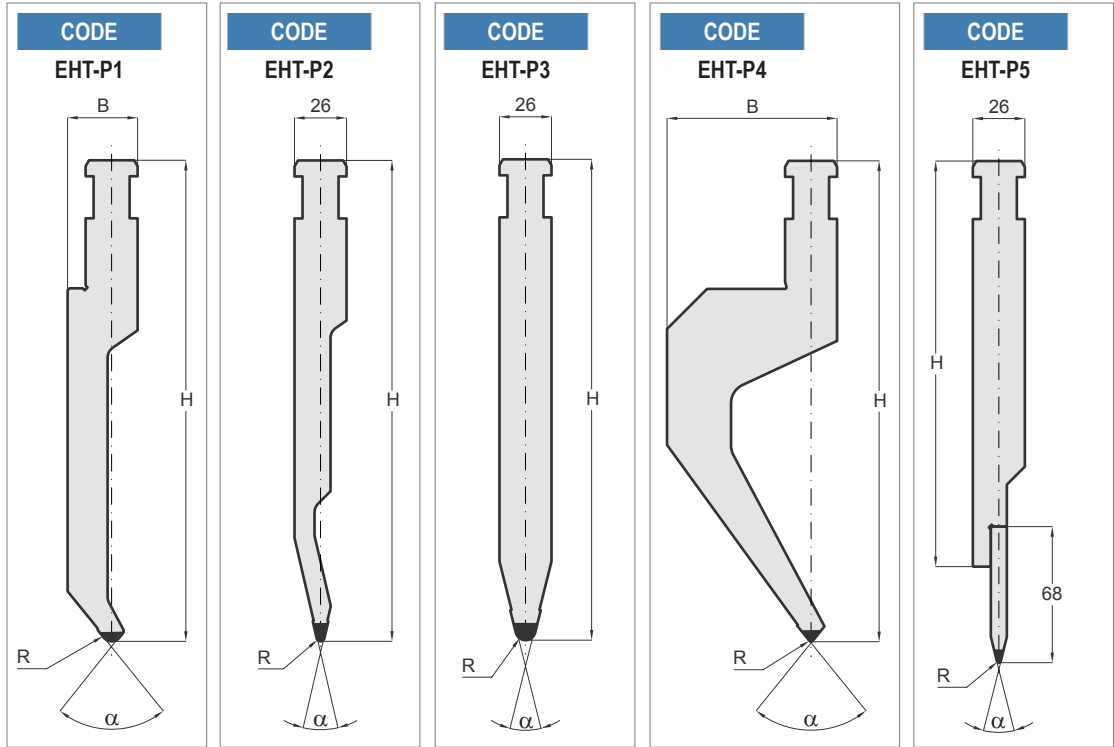

2100 mm | 2600 mm | 3100 mm | 3600 mm | 4100 mm (SECTIONED)

SPECIFICARE DIMENSIONI / SPECIFY DIMENSIONS

# MATRICI / DIES EHT STYLE

LE MATRICI SONO PRODOTTE SU RICHIESTA NELLE LUNGHEZZE DI: 2100 mm, 2600 mm, 3100 mm, 3600 mm E 4100 mm (FRAZIONATI)

THE DIES ARE PRODUCED ON REQUEST IN THE FOLLOWING LENGTHS: 2100 mm, 2600 mm, 3100 mm, 3600 mm AND 4100 mm (SECTIONED)

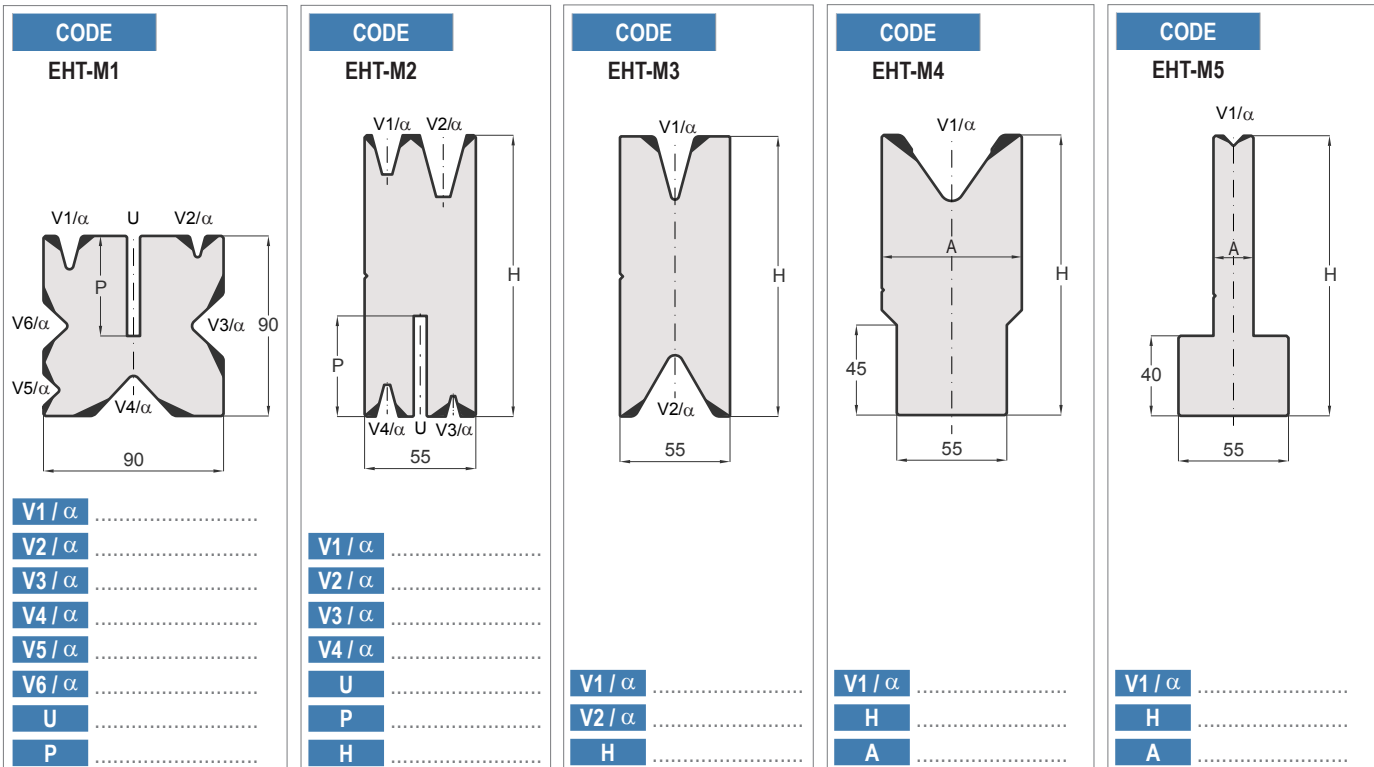

V1 /  $\alpha$  .....  
 V2 /  $\alpha$  .....  
 V3 /  $\alpha$  .....  
 V4 /  $\alpha$  .....  
 V5 /  $\alpha$  .....  
 V6 /  $\alpha$  .....  
 U .....  
 P .....

V1 /  $\alpha$  .....  
 V2 /  $\alpha$  .....  
 V3 /  $\alpha$  .....  
 V4 /  $\alpha$  .....  
 U .....  
 P .....  
 H .....

V1 /  $\alpha$  .....  
 V2 /  $\alpha$  .....  
 H .....

V1 /  $\alpha$  .....  
 H .....  
 A .....

V1 /  $\alpha$  .....  
 H .....  
 A .....

2100 mm | 2600 mm | 3100 mm | 3600 mm | 4100 mm (SECTIONED)

SPECIFICARE DIMENSIONI / SPECIFY DIMENSIONS

# PUNZONI / PUNCHES **NEWTON STYLE**

I PUNZONI SONO PRODOTTI A RICHIESTA NELLE LUNGHEZZE DI: 510 mm, 1030 mm E FRAZIONATI (1010 mm)  
 THE PUNCHES ARE PRODUCED ON REQUEST IN THE FOLLOWING LENGTHS: 510 mm, 1030 mm AND SECTIONED (1010 mm)

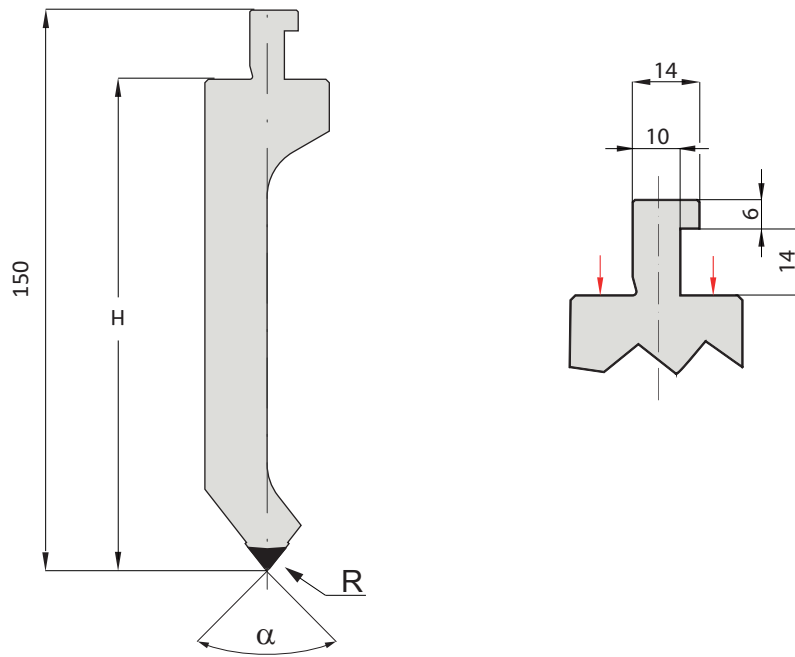

510 mm | 1030 mm | 1010 mm SECTIONED

LEGENDA	$\alpha$ = ANGOLO	R = RAGGIO	H = ALTEZZA
LEGEND	$\alpha$ = ANGLE	R = RADIUS	H = HEIGHT

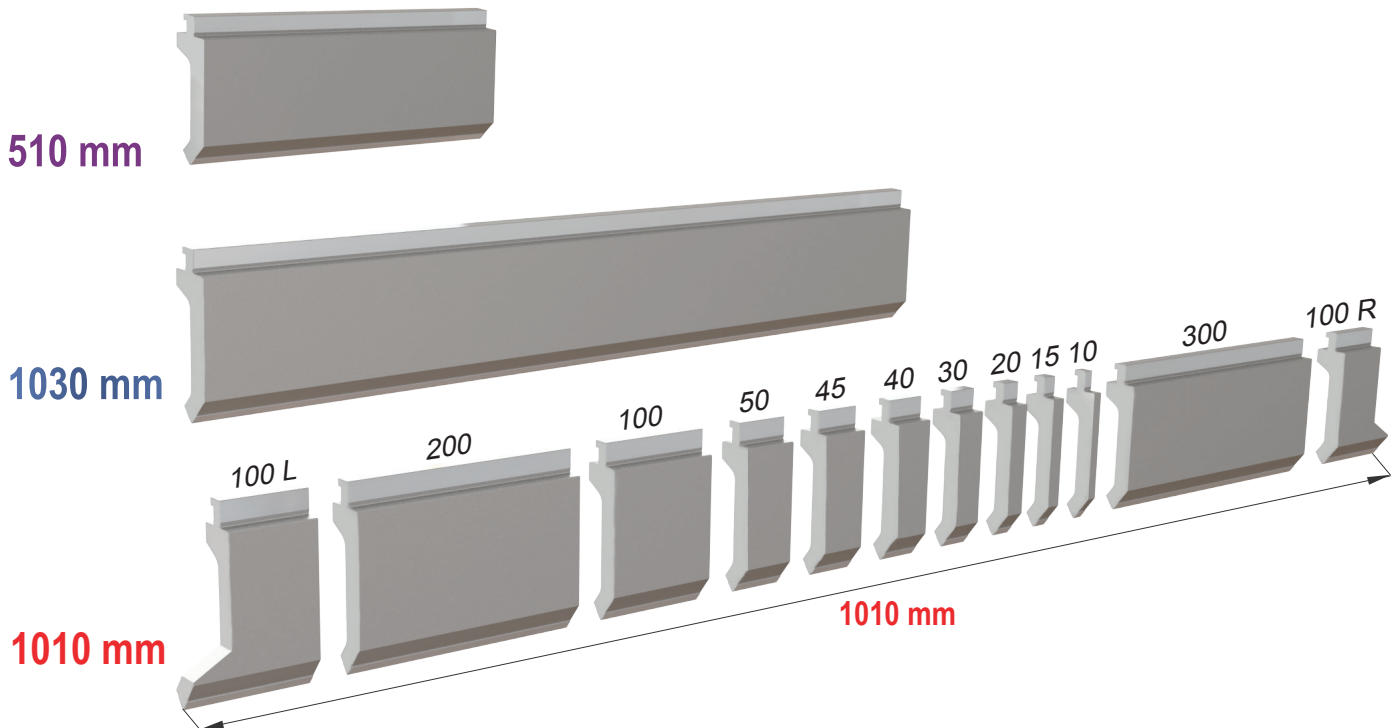

IL CARICO MASSIMO DELLE SCARPETTE CORRISPONDE AL 50% DEL CARICO MASSIMO INDICATO SUL PUNZONE.  
 THE MAX LOAD OF THE HORN EXTENSIONS IS 50% OF THE MAX LOAD OF THE PUNCH.



# PUNZONI / PUNCHES ADATTATORI / ADAPTERS **NEWTON STYLE**

CODE	L	H	T/Mt	Mt
50.930	150	100.00	100	■

ADATTATORE  
ADAPTER  
**NEWTON / AMADA**

CODE	L	H	T/Mt	Mt
50.935	150	100.00	100	■

ADATTATORE  
ADAPTER  
**AMADA / NEWTON**

CODE	$\alpha$	R	H	T/Mt	Mt
18.100	76°	1.00	130.00	100	■

510 mm  
1030 mm  
1010 mm  
SECTIONED



# MATRICI / DIES **NEWTON STYLE**

CODE	$\alpha$	H	T/Mt	Mt
28.820	60° - 80°	90	80	■

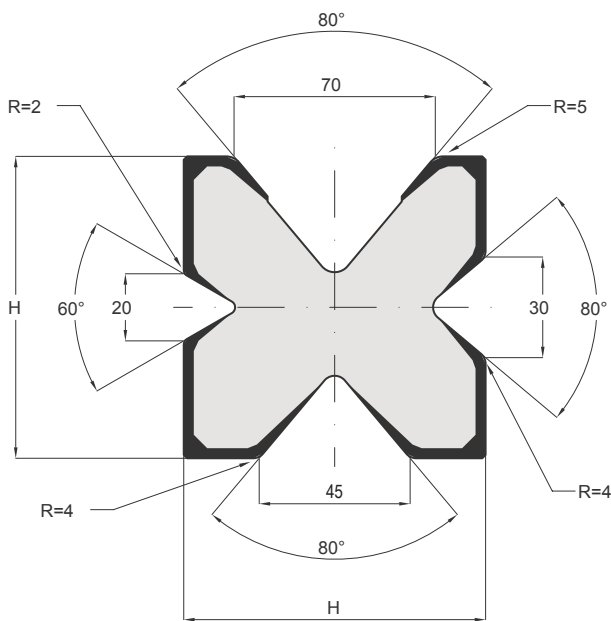

415 mm | 835 mm | 805 mm SECTIONED

LE MATRICI SONO PRODOTTE SU RICHIESTA NELLE LUNGHEZZE DI: 415 mm, 835 mm E 805 mm (FRAZIONATI)  
 THE DIES ARE PRODUCED ON REQUEST IN THE FOLLOWING LENGTHS: 415 mm, 835 mm AND 805 mm (SECTIONED)

# MATRICI / DIES **NEWTON STYLE**

CODE	$\alpha$	H	T/Mt	Mt
28.100	80°	90	80	■

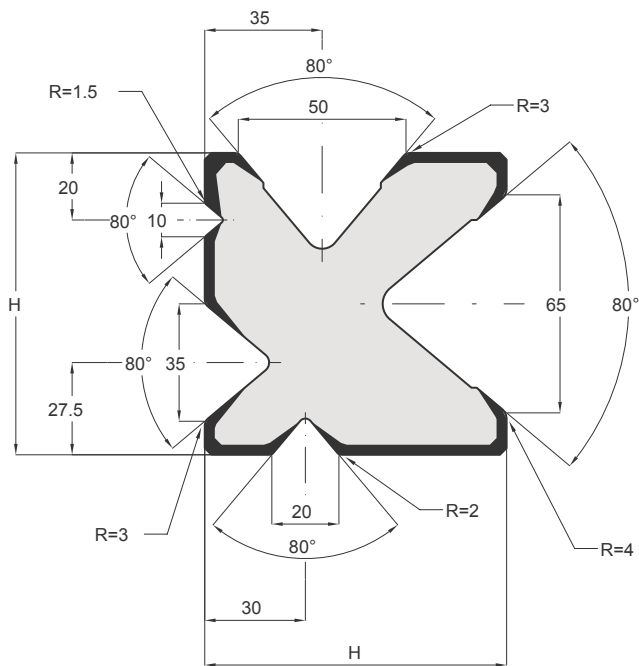

510 mm | 1030 mm | 1010 mm SECTIONED

LE MATRICI SONO PRODOTTE SU RICHIESTA NELLE LUNGHEZZE DI: 510 mm, 1030 mm E 1010 mm (FRAZIONATI)  
 THE DIES ARE PRODUCED ON REQUEST IN THE FOLLOWING LENGTHS: 510 mm, 1030 mm AND 1010 mm (SECTIONED)

# PUNZONI / PUNCHES WEINBRENNER STYLE

I PUNZONI SONO PRODOTTI A RICHIESTA NELLE LUNGHEZZE DI: 2050 mm, 2550 mm, 3050 mm, 3550 mm E 4050 mm (FRAZIONATI)

THE PUNCHES ARE PRODUCED ON REQUEST IN THE FOLLOWING LENGTHS: 2050 mm, 2550 mm, 3050 mm, 3550 mm AND 4050 mm (SECTIONED)

CODE	W-P1	W-P2	W-P3	W-P4	W-P5
Diagram					
Dimensions	26	B	B	B	26
Height	H	H	H	H	H
Radius	R	R	R	R	R
Angle	$\alpha$	$\alpha$	$\alpha$	$\alpha$	$\alpha$
Additional					80

**CODE** .....  
**H =** .....  
**B =** .....  
**R =** .....  
 **$\alpha =$**  .....

2050 mm | 2550 mm | 3050 mm | 3550 mm | 4050 mm (SECTIONED)

SPECIFICARE DIMENSIONI / SPECIFY DIMENSIONS

# MATRICI / DIES WEINBRENNER STYLE

LE MATRICI SONO PRODOTTE SU RICHIESTA NELLE LUNGHEZZE DI: 2050 mm, 2550 mm, 3050 mm, 3550 mm E 4050 mm (FRAZIONATI)

THE DIES ARE PRODUCED ON REQUEST IN THE FOLLOWING LENGTHS: 2050 mm, 2550 mm, 3050 mm, 3550 mm AND 4050 mm (SECTIONED)

CODE	W-M1	W-M2	W-M3	W-M4	W-M5
Diagram					
Dimensions	40, 35	40, 35	40, 35	40, 35	40, 35
Height	H	H	H	H	H
Angles	$V1/\alpha$	$V1/\alpha$	$V1/\alpha$	$V1/\alpha, V2/\alpha$	$V1/\alpha, V2/\alpha$
Additional	A	A	$V2/\alpha$	$V3/\alpha$	$V3/\alpha, V4/\alpha$

**V1 /  $\alpha$**  .....  
**H** .....  
**A** .....

**V1 /  $\alpha$**  .....  
**H** .....  
**A** .....

**V1 /  $\alpha$**  .....  
**V2 /  $\alpha$**  .....  
**H** .....

**V1 /  $\alpha$**  .....  
**V2 /  $\alpha$**  .....  
**V3 /  $\alpha$**  .....  
**H** .....

**V1 /  $\alpha$**  .....  
**V2 /  $\alpha$**  .....  
**V3 /  $\alpha$**  .....  
**V4 /  $\alpha$**  .....  
**H** .....

2050 mm | 2550 mm | 3050 mm | 3550 mm | 4050 mm (SECTIONED)

SPECIFICARE DIMENSIONI / SPECIFY DIMENSIONS

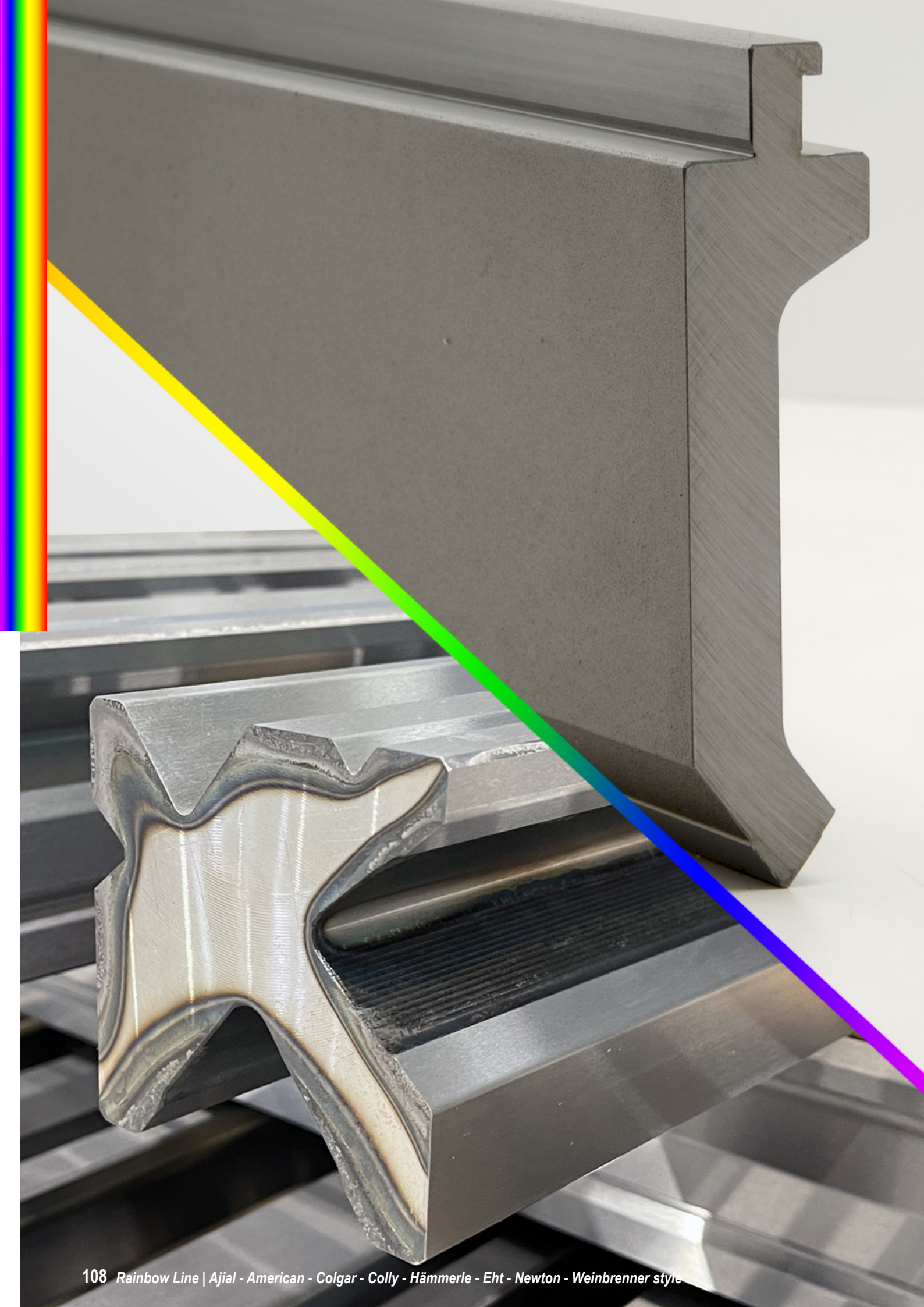

# AMADA / TRUMPF / WILA / BYSTRONIC LVD / EHT / WEINBRENNER STYLE

LAME / BLADES

SUPPORTO PER LAME / BLADES HOLDER

INSERTI A (Z) / Z TOOL INSERTS

SUPPORTI PER INSERTI A (Z) / Z TOOL HOLDERS

INSERTI RAGGIATI / RADIUS INSERTS

SUPPORTI PER INSERTI RAGGIATI / RADIUS INSERT HOLDERS

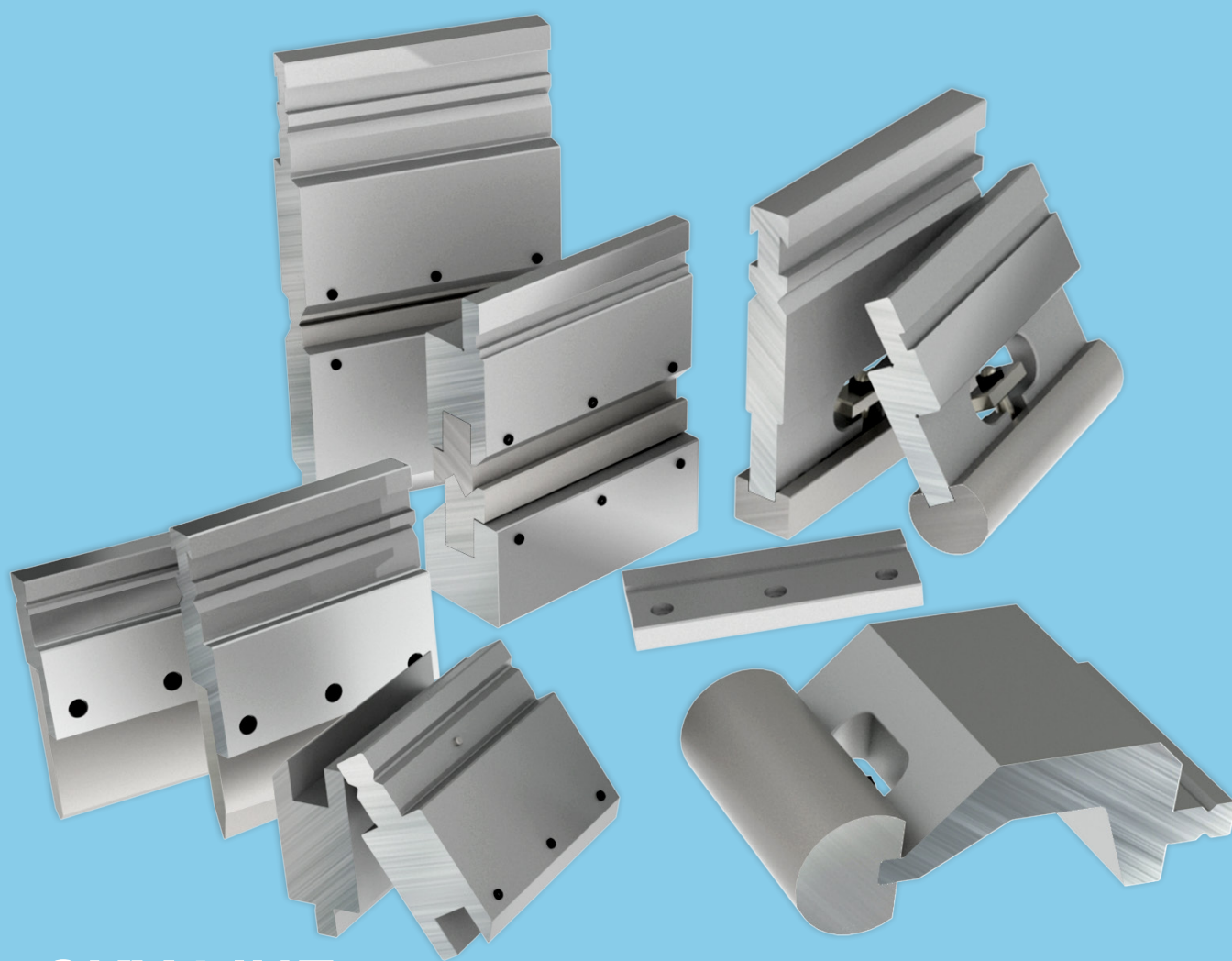

## SKY LINE

AMADA / TRUMPF / WILA / BYSTRONIC  
LVD / EHT / WEINBRENNER STYLE



# SUPPORTO PER LAME / BLADES HOLDER

## AMADA - TRUMPF - WILA - BYSTRONIC - LVD - EHT - WEINBRENNER STYLE

CODE	H	T/Mt	Mt
10.400	60.00	25	■

100 mm  
200 mm  
300 mm  
500 mm  
488 mm SECTIONED

**AMADA / PROMECAM**

CODE	H	T/Mt	Mt
15.760	120.00	100	■

100 mm  
200 mm  
300 mm  
500 mm  
488 mm SECTIONED

**TRUMPF - WILA - LVD**

CODE	H	T/Mt	Mt
15.755	57.00	100	■

100 mm  
200 mm  
300 mm  
500 mm  
488 mm SECTIONED

**TRUMPF - WILA - LVD**

CODE	H	T/Mt	Mt
14.280	95.00	100	■

100 mm  
200 mm  
300 mm  
500 mm  
488 mm SECTIONED

**BYSTRONIC - R**

CODE	H	T/Mt	Mt
14.281	90.00	100	■

100 mm  
200 mm  
300 mm  
500 mm  
488 mm SECTIONED

**BYSTRONIC - S**

CODE	H	T/Mt	Mt
14.282	70.00	100	■

100 mm  
200 mm  
300 mm  
500 mm  
488 mm SECTIONED

**BYSTRONIC - RFA**

CODE	H	T/Mt	Mt
16.070	120.00	100	■

100 mm  
200 mm  
300 mm  
500 mm  
488 mm SECTIONED

**LVD**

CODE	H	T/Mt	Mt
17.070	96.00	100	■

100 mm  
200 mm  
300 mm  
500 mm  
488 mm SECTIONED

**EHT**

CODE	H	T/Mt	Mt
17.570	123.00	100	■

100 mm  
200 mm  
300 mm  
500 mm  
488 mm SECTIONED

**WEINBRENNER**

# LAME / BLADES

AMADA - TRUMPF - WILA - BYSTRONIC - LVD - EHT - WEINBRENNER STYLE

CODE	$\alpha$	R	H	T/Mt	Mt
15.776	86°	1.00	100.00	100	■
15.774	84°	1.00	100.00	100	■
15.769	28°	6.00	100.00	100	■
15.768	28°	5.00	100.00	100	■
15.767	28°	4.00	100.00	100	■
15.766	28°	3.00	100.00	100	■
15.765	28°	2.00	100.00	100	■
15.763	28°	1.00	100.00	100	■
15.761	28°	0.50	100.00	100	■

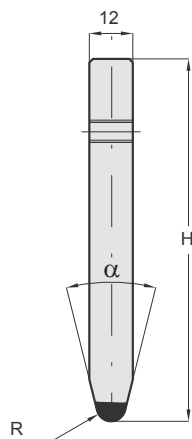

100 mm | 200 mm | 300 mm | 500 mm | 550 mm SECTIONED

LEGENDA	$\alpha$ = ANGOLO	R = RAGGIO	H = ALTEZZA	K = PARTI USURABILI
LEGEND	$\alpha$ = ANGLE	R = RADIUS	H = HEIGHT	K = WEAR PARTS

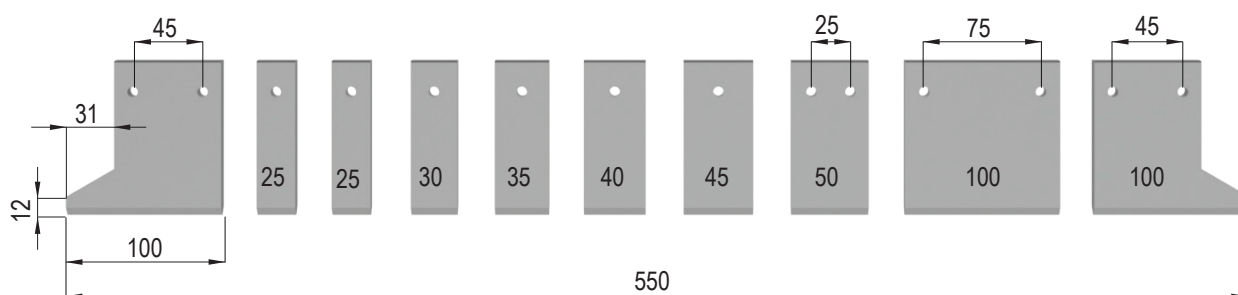
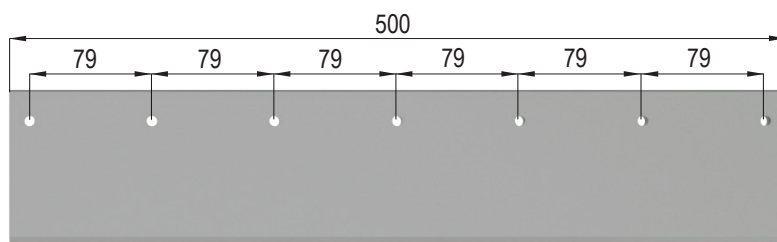
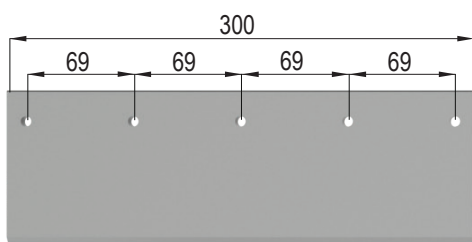
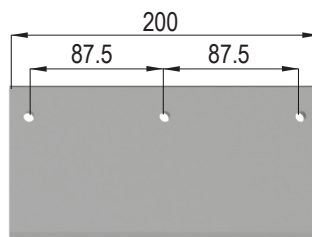
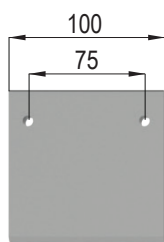

IL CARICO MASSIMO DELLE SCARPETTE CORRISPONDE AL 50% DEL CARICO MASSIMO INDICATO SOPRA LA LAMA.  
 THE MAX LOAD OF THE HORN EXTENSIONS IS 50% OF THE MAX LOAD OF THE BLADE.

# SUPPORTI PER INSERTI A (Z) / Z TOOL HOLDERS

AMADA - TRUMPF - WILA - BYSTRONIC - LVD - EHT - WEINBRENNER STYLE

CODE	H1	H2	T/Mt	Mt
40.419	42.00	36.00	100	■

415 mm  
835 mm

**AMADA / PROMECAM**

CODE	H1	H2	T/Mt	Mt
15.050	62.00	64.00	100	■

415 mm  
835 mm

**TRUMPF - WILA**

CODE	H1	H2	T/Mt	Mt
16.050	144	90	100	■

415 mm  
835 mm

**LVD**

CODE	H1	H2	T/Mt	Mt
16.060	62.00	90.00	100	■

415 mm  
835 mm

**LVD**

CODE	H1	H2	T/Mt	Mt
17.050	189	64	100	■

415 mm  
835 mm

**EHT**

CODE	H1	H2	T/Mt	Mt
17.550	139	64	100	■

415 mm  
835 mm

**WEINBRENNER**

CODE	H1	H2	T/Mt	Mt
14.095	42	64	100	■

415 mm  
835 mm

**EURO - BYSTRONIC**

CODE	H1	H2	T/Mt	Mt
14.090	101	64	100	■

415 mm  
835 mm

**BYSTRONIC - S**

CODE	H1	H2	T/Mt	Mt
14.085	101	64	100	■

415 mm  
835 mm

**BYSTRONIC - R**

CODE	H1	H2	T/Mt	Mt
14.080	121	64	100	■

415 mm  
835 mm

**BYSTRONIC - RFA**



# INSERTI A (Z) / Z TOOL INSERTS

AMADA - TRUMPF - WILA - BYSTRONIC - LVD - EHT - WEINBRENNER STYLE

LEGENDA	Z = SALTO A Z	$\alpha$ = ANGOLO	R = RAGGIO	T/mt = CARICO MAX	Mt = MATERIALE	T = SPESSORE MAX
LEGEND	Z = Z OFFSET	$\alpha$ = ANGLE	R = RADIUS	T/mt = MAX LOAD	Mt = MATERIAL	T = MAX THICKNESS

CODE	Z	$\alpha$	R	T/Mt	Mt	T= MAX THICKNESS
40.500				100		

415 mm | 835 mm

CODE	Z	$\alpha$	R	T/Mt	Mt	T= MAX THICKNESS
40.510	1.00	160°	0.5	100		1 mm
40.515	1.50	160°	0.5	100		1.2 mm
40.520	2.00	150°	0.5	100		1.5 mm
40.525	2.50	140°	0.5	100		1.5 mm

415 mm | 835 mm

CODE	Z	$\alpha$	R	T/Mt	Mt	T= MAX THICKNESS
40.511	1.00	90°	0.3	100		0.5 mm
40.516	1.50	90°	0.3	100		0.5 mm
40.521	2.00	90°	0.5	100		0.5 mm
40.526	2.50	90°	0.5	100		0.8 mm
40.530	3.00	90°	0.5	100		1 mm
40.535	3.50	90°	0.5	100		1 mm
40.540	4.00	90°	0.5	100		1.2 mm
40.545	4.50	90°	0.5	100		1.2 mm
40.550	5.00	90°	0.5	100		1.5 mm
40.555	5.50	90°	0.5	100		1.5 mm
40.560	6.00	90°	0.5	100		1.5 mm
40.565	6.50	90°	0.5	100		1.5 mm
40.570	7.00	90°	0.5	100		1.5 mm
40.575	7.50	90°	0.5	100		1.6 mm
40.580	8.00	90°	0.5	100		1.6 mm

415 mm | 835 mm







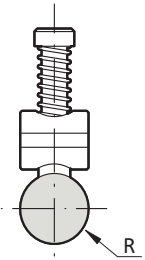

CODE	Z	$\alpha$	R	T/Mt	Mt	T= MAX THICKNESS
40.585	8.50	90°	0.8	100		2 mm
40.590	9.00	90°	0.8	100		2 mm
40.610	10.00	90°	0.8	100		2 mm
40.611	11.00	90°	1	100		2 mm
40.612	12.00	90°	1	100		2 mm

415 mm | 835 mm

CODE	Z	$\alpha$	R	T/Mt	Mt	T= MAX THICKNESS
40.613	13.00	90°	1	100		2.5 mm
40.614	14.00	90°	1	100		2.5 mm
40.615	15.00	90°	1	100		3 mm

415 mm | 835 mm

# INSERTI RAGGIATI / RADIUS INSERTS AMADA

ACCIAIO - STEEL C45	CODE	Mt	R	L
	10.181		3.00	A
	10.182		3.50	A
	10.183		4.00	A
	10.184		4.50	A
	10.185		5.00	B
	10.186		5.50	B
	10.187		6.00	B
	10.188		6.50	B

  

LEGENDA	L = LATO	R = RAGGIO
LEGEND	L = SIDE	R = RADIUS

CODE	T/Mt	Mt
10.180	80	

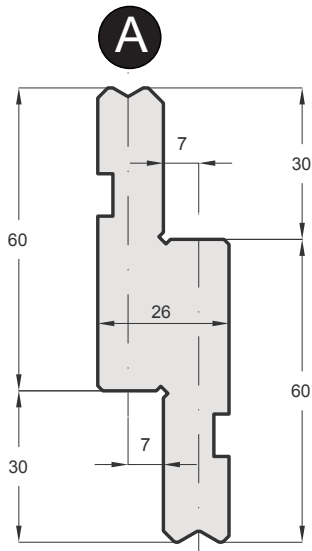
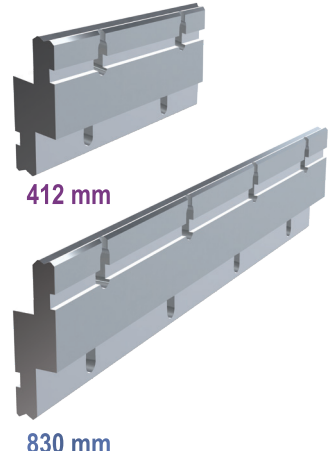

  

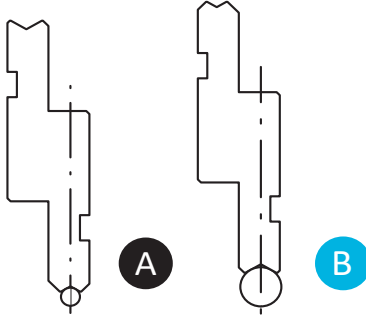

**HOLDER AMADA**

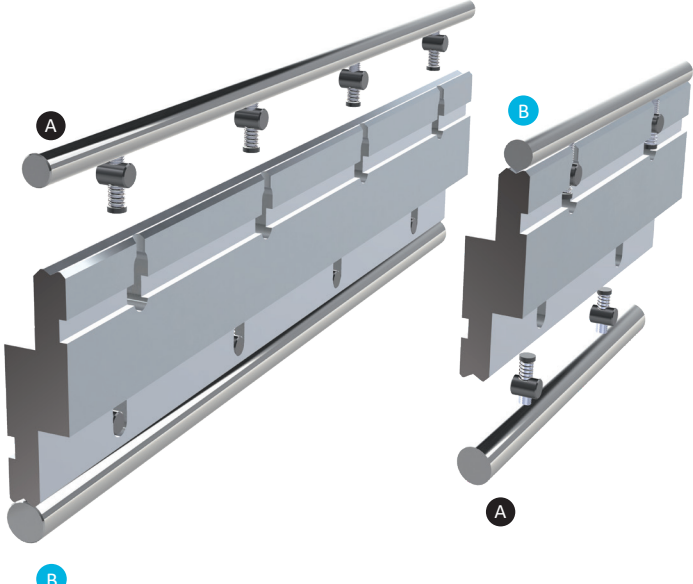

R 3.0 Min  
R 4.5 Max

R 5.0 Min  
R 6.5 Max

**CODE**  
40.003

**SPARE PARTS**

# INSERTI RAGGIATI / RADIUS INSERTS

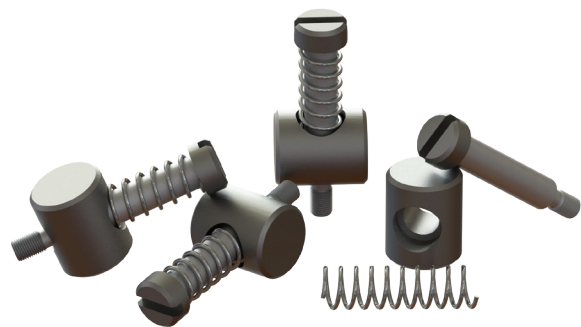
## AMADA - TRUMPF - WILA - BYSTRONIC - LVD - EHT - WEINBRENNER STYLE

ACCIAIO - STEEL C45	CODE	Mt	R	A	B	CODE	Mt	STEEL 42CrMo4 (UNI EN 10083-93) NITRIDED 60-62 HRC
	10.300	■	7.00	11.50		11.300	■	
	10.301	■	7.50	11.50		11.301	■	
	10.302	■	8.00	13.00		11.302	■	
	10.303	■	9.00	16.00		11.303	■	
	10.304	■	10.00	16.00		11.304	■	
	10.305	■	11.00	16.00		11.305	■	
	10.306	■	11.50	19.00		11.306	■	
10.307	■	12.00	20.00		11.307	■		

	10.308	■	12.50	16.00	21.00	11.308	■	
	10.309	■	13.00	17.00	23.00	11.309	■	
	10.310	■	14.00	19.00	25.00	11.310	■	
	10.311	■	15.00	20.00	27.00	11.311	■	
	10.312	■	16.00	21.00	28.00	11.312	■	
	10.313	■	17.00	21.50	31.50	11.313	■	
	10.314	■	17.50	22.00	32.00	11.314	■	
	10.315	■	19.00	25.00	32.00	11.315	■	
	10.316	■	20.00	24.00	34.00	11.316	■	
	10.317	■	22.50	25.00	33.00	11.317	■	
	10.318	■	25.00	29.00	39.00	11.318	■	
	10.319	■	27.50	34.00	44.00	11.319	■	
	10.320	■	30.00	34.00	44.00	11.320	■	
	10.321	■	35.00	45.00	55.00	11.321	■	
	10.322	■	40.00	45.00	55.00	11.322	■	
	10.323	■	45.00	50.00	60.00	11.323	■	
10.324	■	50.00	54.00	64.00	11.324	■		

	CODE	Mt	R	A	B	
	10.325	■	17.00	22.00		
<p>ACCIAIO - STEEL C45 (UNI EN 10083 W.1. : 1.1191)</p>						

CODE	40.002		
SPARE PARTS			

**SUPPORTI PER INSERTI RAGGIATI / RADIUS INSERTS HOLDERS**  
**AMADA - TRUMPF - WILA - BYSTRONIC - LVD - EHT - WEINBRENNER STYLE**

CODE	H	T/Mt	Mt
10.115	67.00	80	■

412 mm  
830 mm

**AMADA**

CODE	H	T/Mt	Mt
10.116	115.00	80	■

412 mm  
830 mm

**AMADA**

CODE	H	T/Mt	Mt
10.190	87.00	50	■

412 mm  
830 mm

**AMADA**

CODE	H	T/Mt	Mt
10.191	115.00	50	■

412 mm  
830 mm

**AMADA**

CODE	H	T/Mt	Mt
15.010	103.00	80	■

412 mm  
830 mm

**TRUMPF - WILA - LVD**

CODE	H	T/Mt	Mt
15.014	160.00	80	■

412 mm  
830 mm

**TRUMPF - WILA - LVD**

CODE	H	T/Mt	Mt
15.018	220.00	80	■

412 mm  
830 mm

**TRUMPF - WILA - LVD**

CODE	H	T/Mt	Mt
16.010	170.00	80	■

412 mm  
830 mm

**LVD**

CODE	H	T/Mt	Mt
17.010	200.00	80	■

412 mm  
830 mm

**EHT**

# SUPPORTI PER INSERTI RAGGIATI / RADIUS INSERTS HOLDERS

AMADA - TRUMPF - WILA - BYSTRONIC - LVD - EHT - WEINBRENNER STYLE

CODE	H	T/Mt	Mt
17.510	165.00	80	

412 mm  
830 mm

**WEINBRENNER**

CODE	H	T/Mt	Mt
14.250	140.00	80	

412 mm  
830 mm

**BYSTRONIC - R**

CODE	H	T/Mt	Mt
14.251	140.00	80	

412 mm  
830 mm

**BYSTRONIC - S**

CODE	H	T/Mt	Mt
14.252	140.00	80	

412 mm  
830 mm

**BYSTRONIC - RFA**

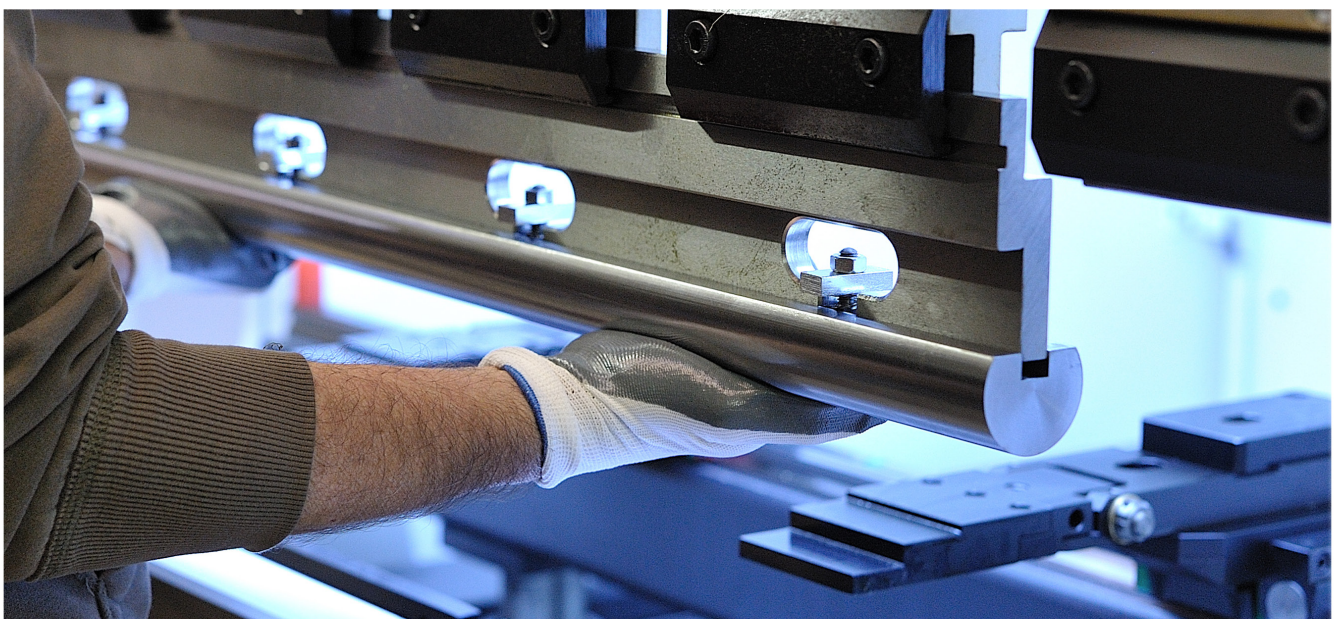

# SUPPORTI PER INSERTI RAGGIATI / RADIUS INSERTS HOLDERS

## AMADA - TRUMPF - WILA STYLE

SUPPORTI ED INSERTI RAGGIATI SONO DISPONIBILI A MAGAZZINO NELLE LUNGHEZZE DI: 100 / 200 / 300 / 500 mm E FRAZIONATI (550 mm)  
 HOLDERS AND RADIUS INSERTS ARE AVAILABLE IN THE FOLLOWING STANDARD LENGTHS: 100 / 200 / 300 / 500 mm AND SECTIONED (550 mm)

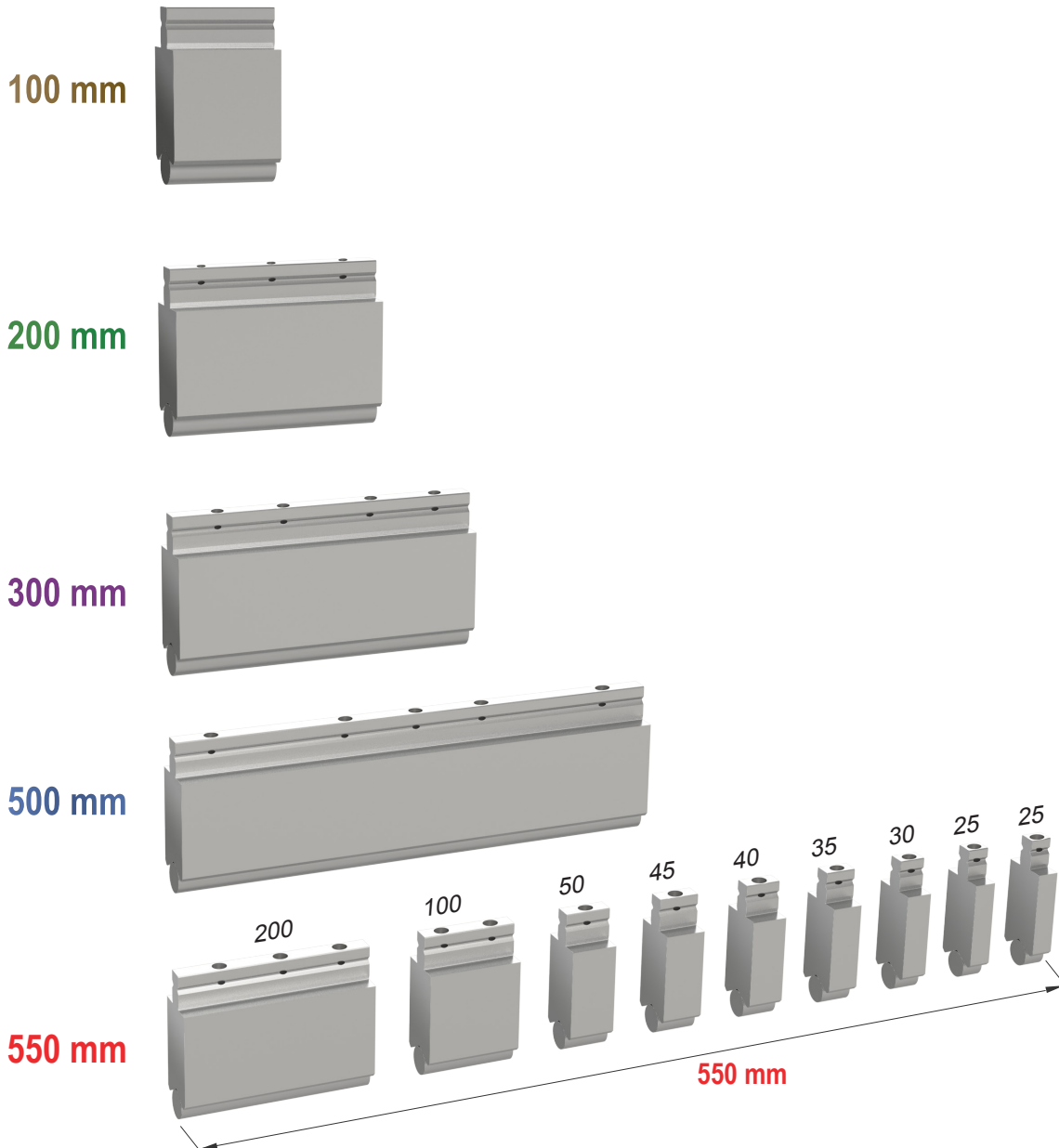

CODE	H	T/Mt	Mt
10.192	86.00	130	AMADA

**A**

100 mm  
200 mm  
300 mm  
500 mm  
550 mm SECTIONED

AMADA	
MIN.	MAX.
R=10	R=25

CODE	H	T/Mt	Mt
10.193	100.00	150	AMADA

**B**

100 mm  
200 mm  
300 mm  
500 mm  
550 mm SECTIONED

AMADA	
MIN.	MAX.
R=15	R=50

CODE	H	T/Mt	Mt
15.020	106.00	130	TRUMPF - WILA - LVD

**A**

100 mm  
200 mm  
300 mm  
500 mm  
550 mm SECTIONED

TRUMPF - WILA - LVD	
MIN.	MAX.
R=10	R=25

CODE	H	T/Mt	Mt
15.025	100.00	150	TRUMPF - WILA - LVD

**B**

100 mm  
200 mm  
300 mm  
500 mm  
550 mm SECTIONED

TRUMPF - WILA - LVD	
MIN.	MAX.
R=15	R=50

# INSERTI RAGGIATI / RADIUS INSERTS AMADA - TRUMPF - WILA STYLE

ACCIAIO - STEEL C45  
(UNI EN 10083 W.1. : 1.1191)

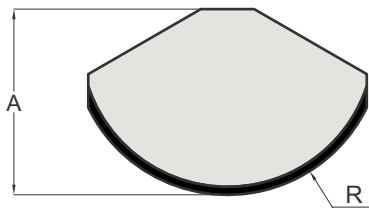
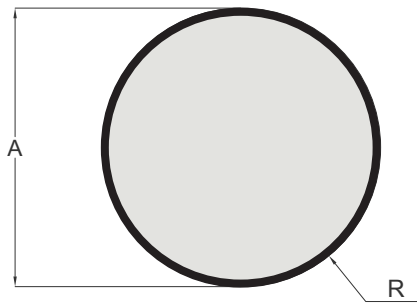

100 mm  
200 mm  
300 mm  
500 mm  
550 mm  
SECTIONED

CODE	Mt	R	A
15.030	■	10.00	20.00
15.031	■	12.50	25.00
15.032	■	15.00	30.00
15.033	■	17.50	35.00
15.034	■	20.00	40.00
15.035	■	25.00	50.00
15.036	■	30.00	60.00
15.037	■	35.00	70.00
15.038	■	40.00	80.00
15.039	■	45.00	89.00
15.040	■	50.00	60.00

LEGENDA	A= ALTEZZA	R = RAGGIO
LEGEND	A = HEIGHT	R = RADIUS

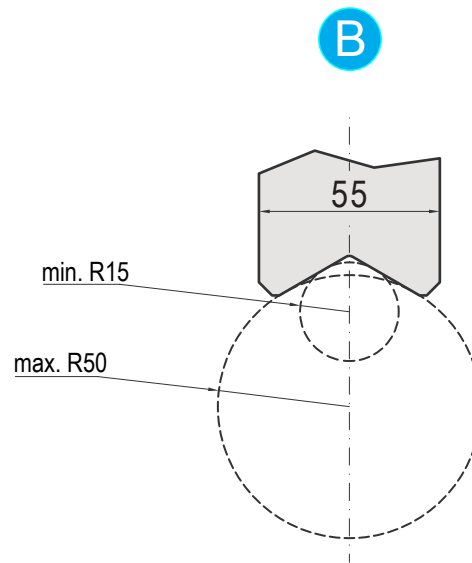
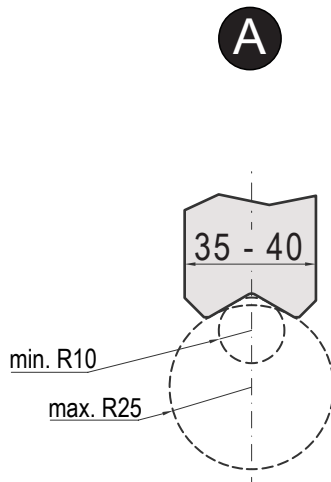

HOLDER CODE

10.192  
10.193

BOLT

TCEI M8x70



HOLDER CODE

15.020  
15.025

BOLT

TCEI M8x90



PARTI DI RICAMBIO - SPARE PARTS - RECAMBIOS - PEÇAS DE SUBSTITUIÇÃO - PIÈCES DE RECHANGE - ERSATZTEILE





# CORAL LINE

UNIBEND E ADATTATORI  
UNIBEND AND ADAPTERS

SUPPORTI E MATRICI A RULLI  
ADAPTERS AND ROLLER DIE

CONTENITORI E INSERTI IN POLIURETANO  
POLYURETHANE INSERTS AND HOLDERS

CONTENITORI E INSERTI NYLON  
NYLON INSERTS AND HOLDERS

PELLICOLE ANTIGRAFFIO E TENDIPELLICOLA  
PROTECTIVE FILM AND FOLDERS



## CORAL LINE

**UTENSILI PER NON MARCARE**  
**NO MARKING TOOLS**



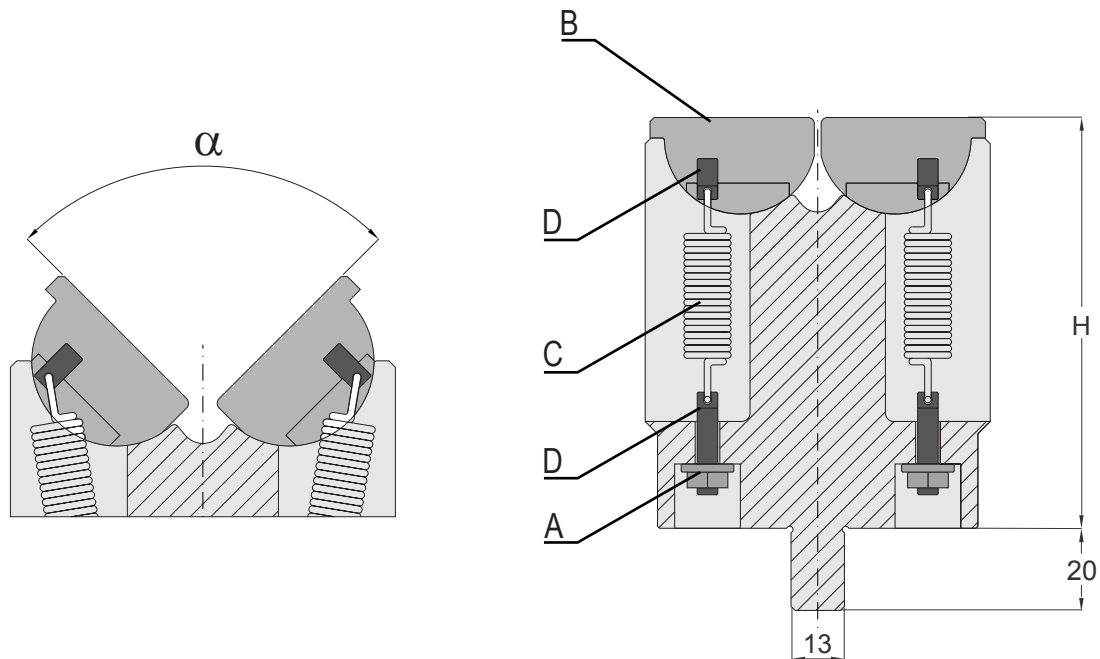

50 mm | 100 mm | 200 mm | 300 mm | 500 mm

LEGENDA	$\alpha$ = ANGOLO	A= DADO TENSIONATORE	B = INSERTO ROTANATE	C = MOLLA A TRAZIONE	D = PERNO TENSORE	H = ALTEZZA
LEGEND	$\alpha$ = ANGLE	A= TENSOR NUTS	B = ROTATING ROOL	C = SPRING	D = PIN	H = HEIGHT

### VANTAGGI DELLE MATRICI UNIBEND CON INSERTI ROTANTI:

- RIDUZIONE DEI TEMPI DI CAMBIO UTENSILE POICHE' CON LA STESSA MATRICE E' POSSIBILE PIEGARE SPESSORI DIVERSI
- RIDUZIONE DEL 90% DEI SEGNI DOVUTI ALLA PIEGATURA
- POSSIBILITA' DI PIEGARE PEZZI CON BORDI STRETTI
- RIDUZIONE DELLA DEFORMAZIONE DI FORI E ASOLE VICINI ALLA LINEA DI PIEGATURA

### ADVANTAGES OF THE UNIBEND DIES WITH ROTATING INSERTS :

- LESS TOOL CHANGE
- REDUCTION OF THE 90% OF THE BENDING MARKS ON SHEET
- SUITABLE FOR V, RADIUS AND U-BENDING
- REDUCTION OF DEFORMATION OF HOLES AND SLOTS CLOSE TO THE BENDING LINE



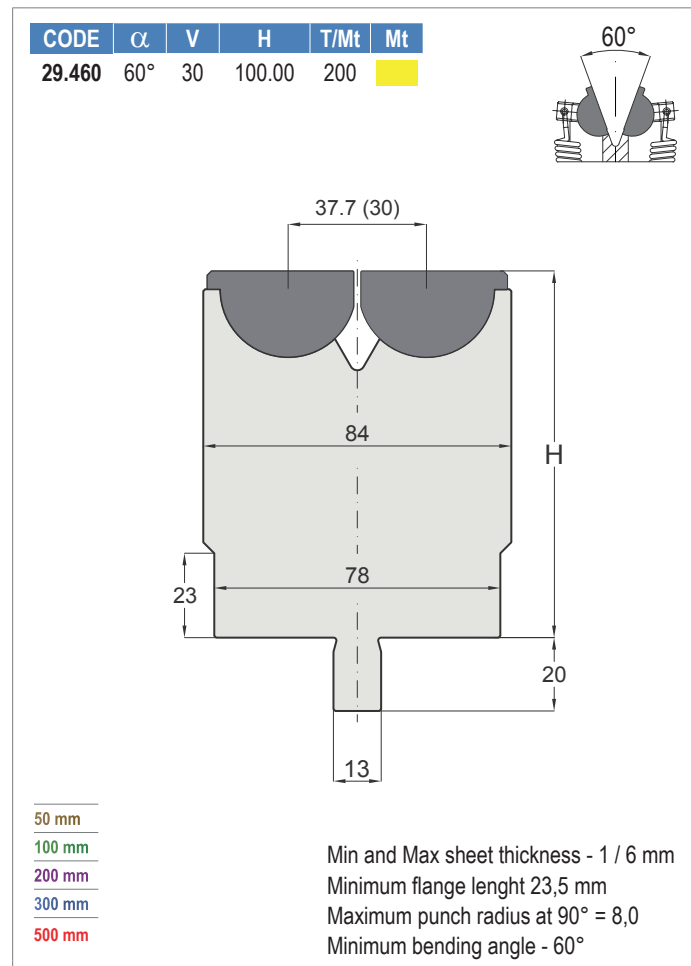
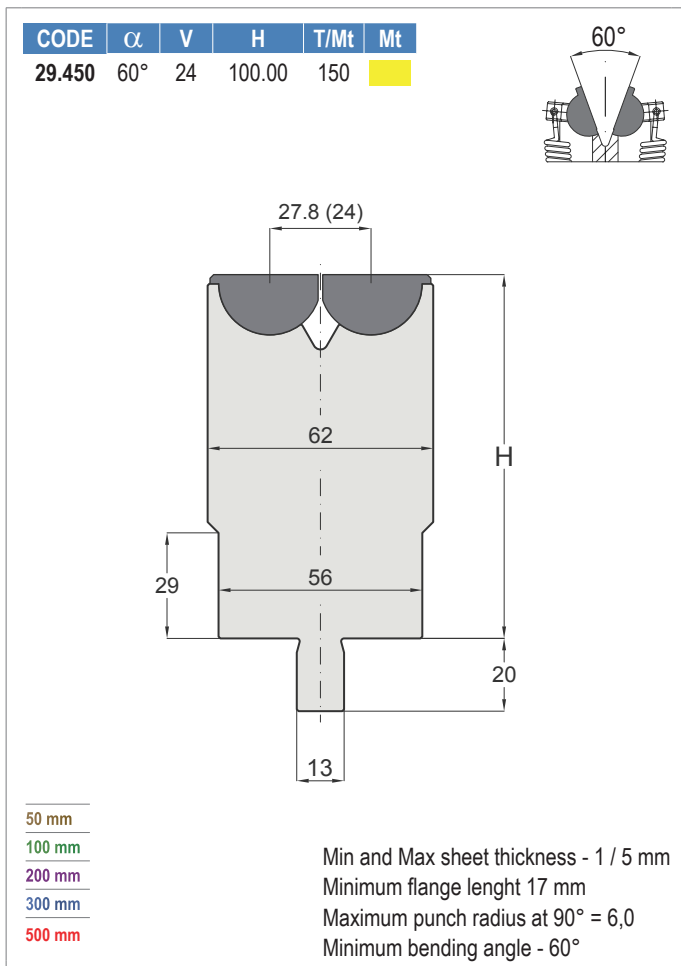
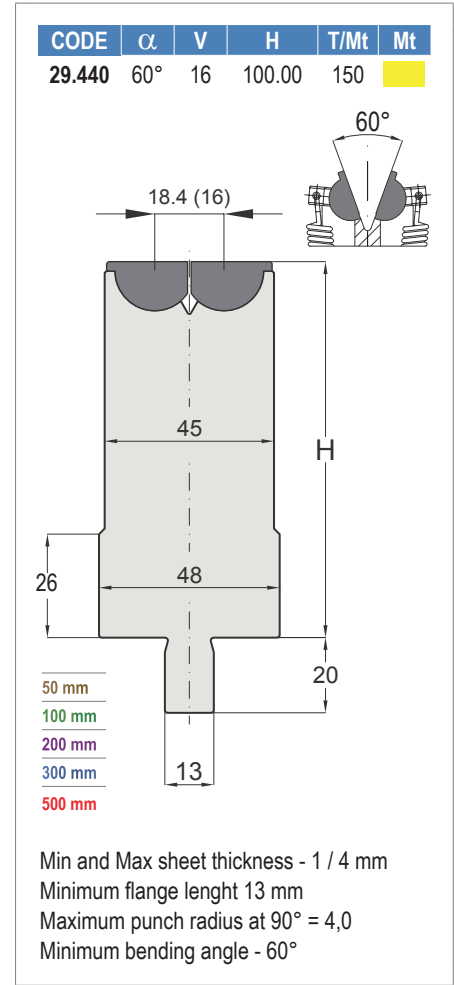
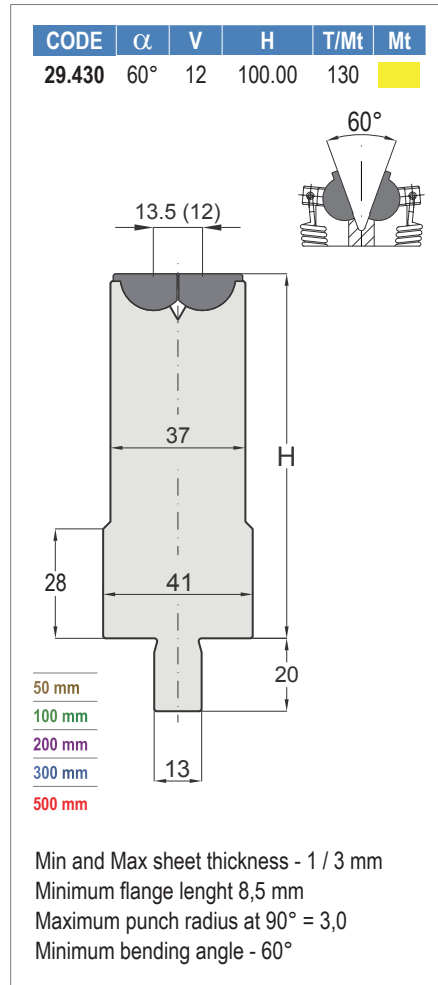
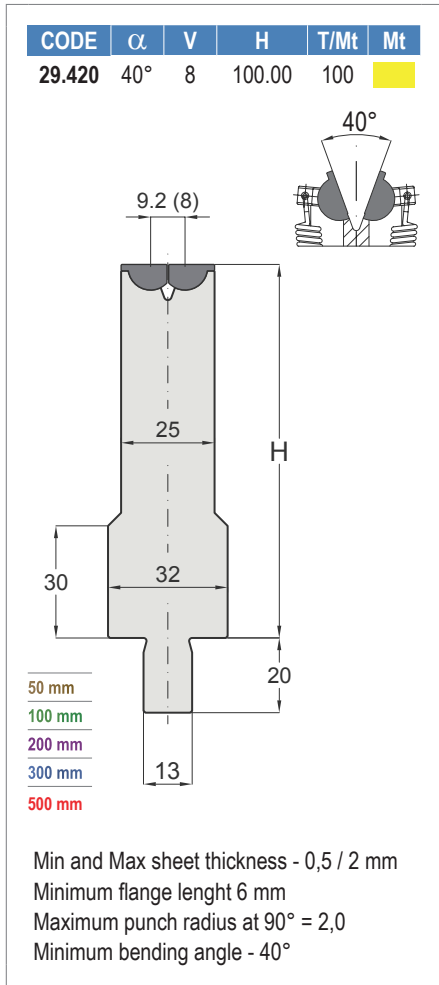

CODE	$\alpha$	V	H	T/Mt	Mt
29.600	60°	60	100.00	100	■

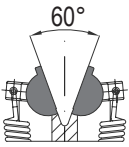
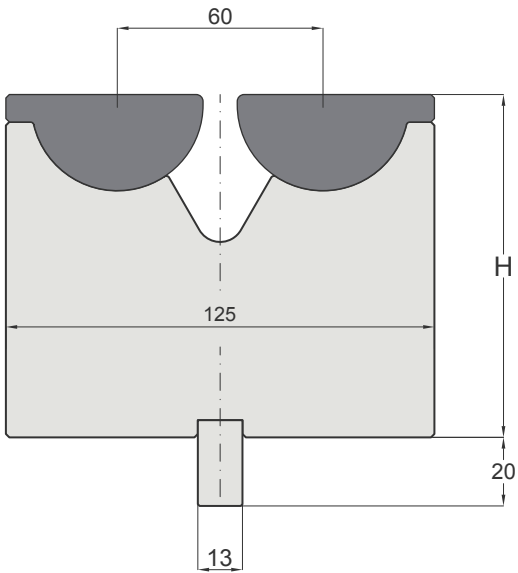
100 mm  
 200 mm  
 300 mm  
 500 mm

Min and Max sheet thickness - 1 / 8 mm  
 Minimum flange length 40 mm  
 Maximum punch radius at 90° = 10,0  
 Minimum bending angle - 60°

CODE	$\alpha$	V	H	T/Mt	Mt
29.850	70°	85	100.00	250	■

100 mm  
 200 mm  
 300 mm  
 500 mm

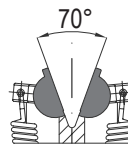
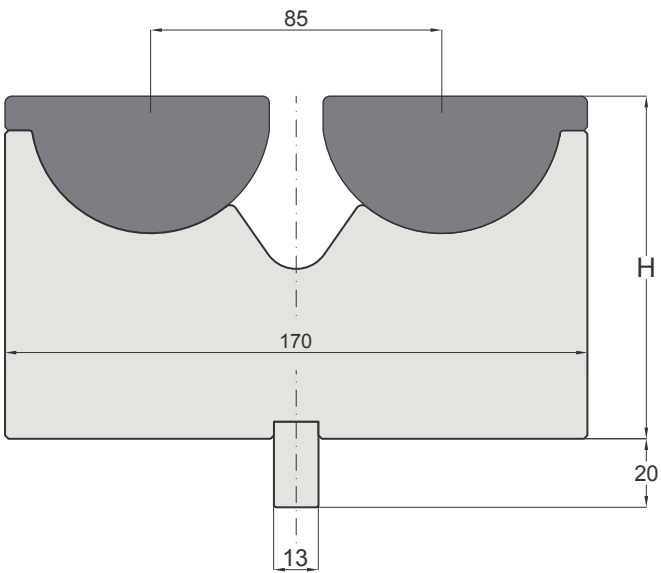
Min and Max sheet thickness - 1 / 12 mm  
 Minimum flange length 55 mm  
 Maximum punch radius at 90° = 13,0  
 Minimum bending angle - 70°

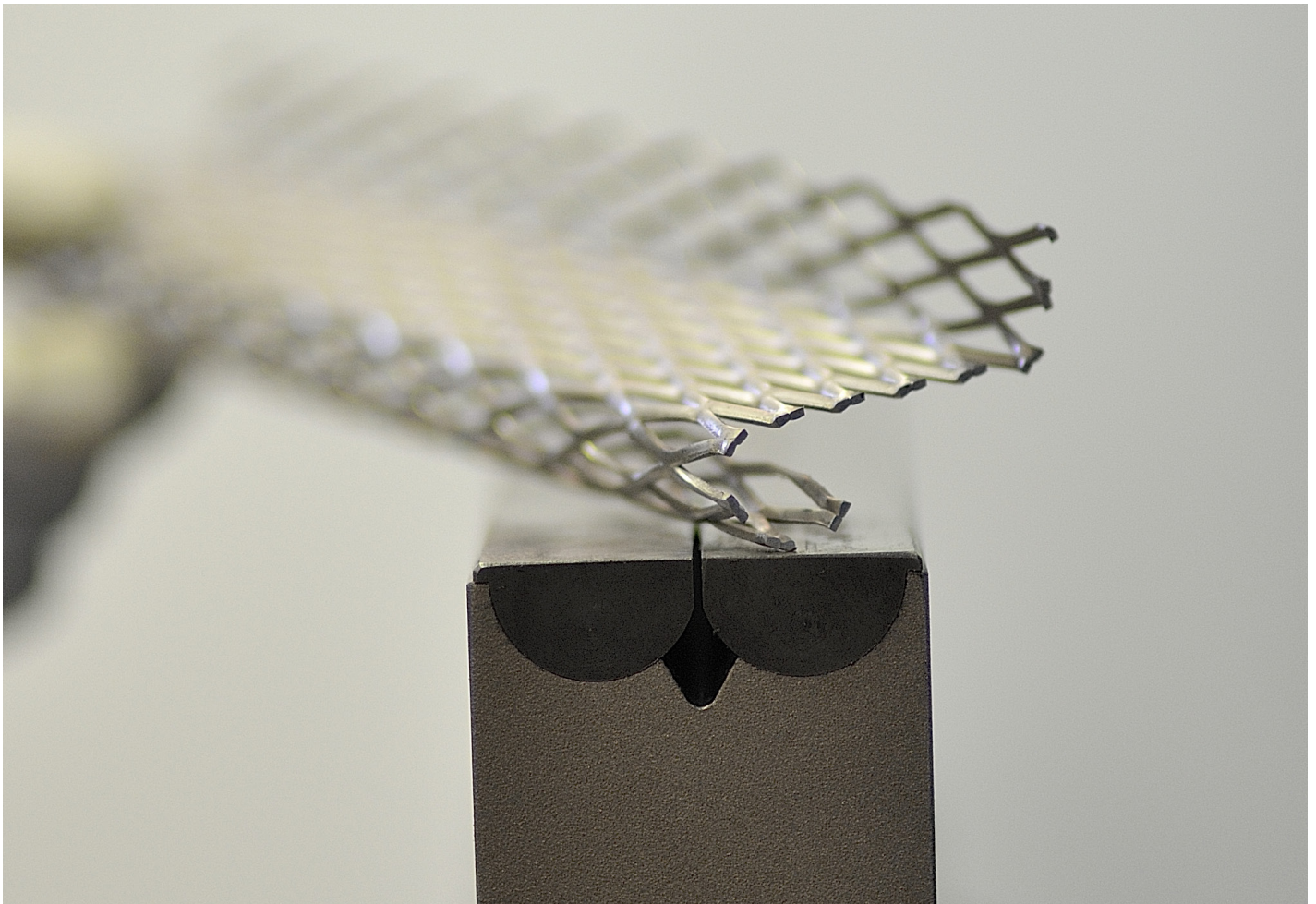

# ADATTATORI INFERIORI - LOWER ADAPTERS UNIBEND

CODE	H	T/Mt	Mt
60.910	30.00	100	■

50 mm  
100 mm  
200 mm  
300 mm  
500 mm  
1000 mm

ADATTATORE INFERIORE - LOWER ADAPTER  
AMADA / WILA - BYSTRONIC

CODE	H	T/Mt	Mt
60.920	60.00	100	■

50 mm  
100 mm  
200 mm  
300 mm  
500 mm  
1000 mm

ADATTATORE INFERIORE - LOWER ADAPTER  
AMADA / WILA - BYSTRONIC

CODE	H	T/Mt	Mt
60.935	30.00	100	■

50 mm  
100 mm  
200 mm  
300 mm  
500 mm  
1000 mm

ADATTATORE INFERIORE - LOWER ADAPTER  
LVD / WILA - BYSTRONIC

CODE	L	H	T/Mt	Mt
60.940	500	40.00	100	■

ADATTATORE INFERIORE - LOWER ADAPTER  
EHT / WILA

CODE	L	H	T/Mt	Mt
60.950	500	45.00	100	■

ADATTATORE INFERIORE - LOWER ADAPTER  
WEINBRENNER / WILA



# UNIBEND - VARIO

180°

CODE	$\alpha$	V	H	T/Mt	Mt
62.094	180°	40 - 100	105.00	150	

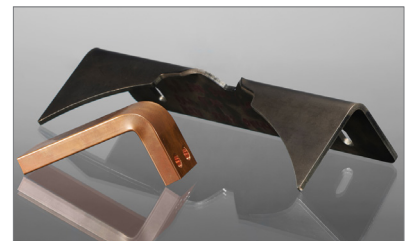
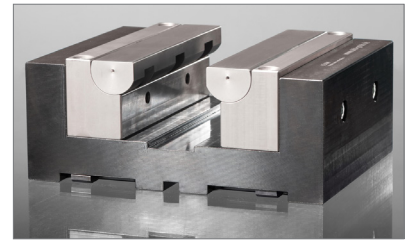
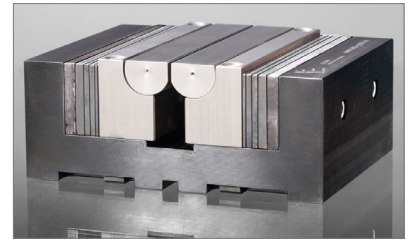
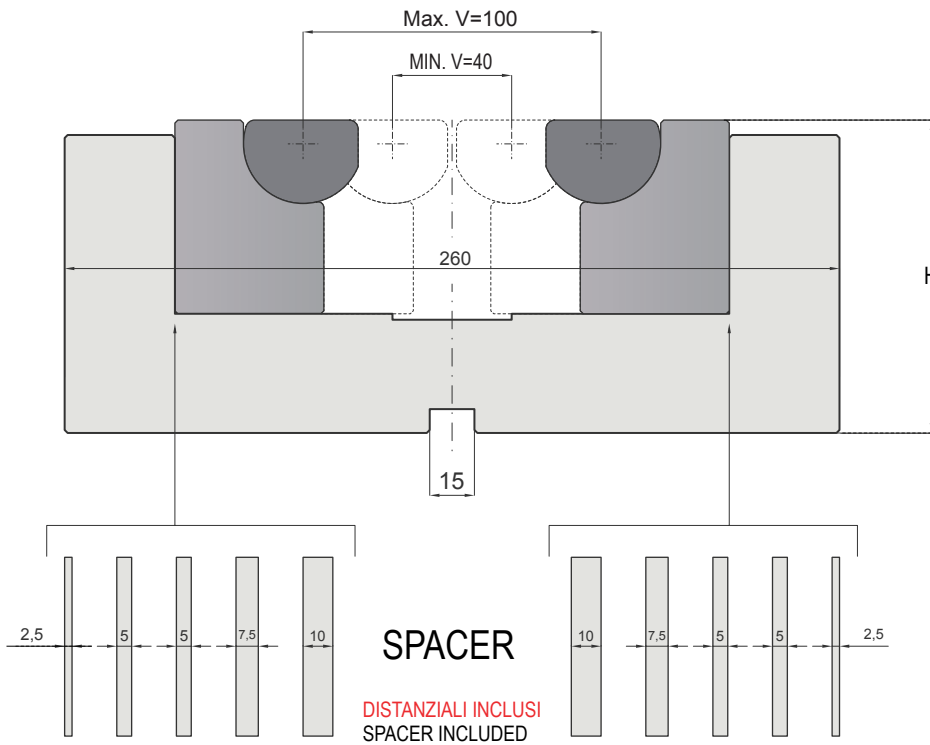

Min and Max sheet thickness - 0,5 / 12 mm  
 Minimum flange length 28 mm (V40) / 70 mm (V100)  
 Maximum punch radius at 90° = 25  
 Minimum bending angle - 180°

LEGENDA	$\alpha$ = ANGOLO	V = AMPIEZZA CAVA	L = LUNGHEZZA	H = ALTEZZA
LEGEND	$\alpha$ = ANGLE	V = DIE OPENING	L = LENGHT	H = HEIGHT



## ADATTATORI ED PARTI DI RICAMBIO ADAPTERS AND SPARE PARTS

CODE	L
60.102	200

**AMADA**

CODE	L
60.103	200

**WILA/TRUMPF**

CODE	L
60.105	200

**LVD**

CODE
40.629

**100 ml**  
**LUBRICATING GREASE**

CODE	L
62.181	200

**RADIUS BENDING/OVERBENDING**

CODE	L
62.182	200

**U - BENDING**

CODE	L
62.183	200

**RADIUS BENDING**



# SUPPORTI E MATRICI A RULLI / ADAPTERS AND ROLLER DIES

CODE	$\alpha$	H	T/Mt	Mt
20.720	80°	170.00	200	■

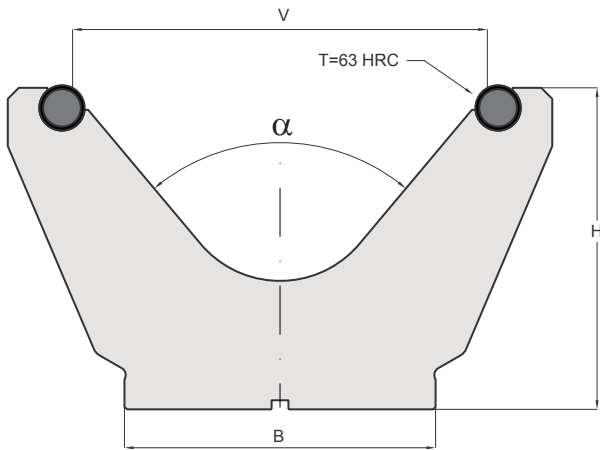

100 mm

LEGENDA	$\alpha$ = ANGOLO	B = BASE	V = AMPIEZZA CAVA	T = TEMPRAAD INDUZIONE	H = ALTEZZA
LEGEND	$\alpha$ = ANGLE	B = BASE	V = DIE OPENING	T = INDUCTION HARDENING	H = HEIGHT

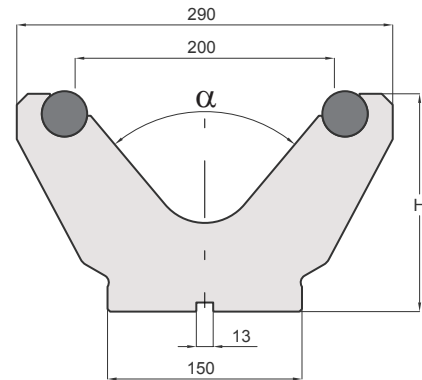

100 mm

CODE	$\alpha$	H	T/Mt	Mt
20.725	80°	200.00	200	■

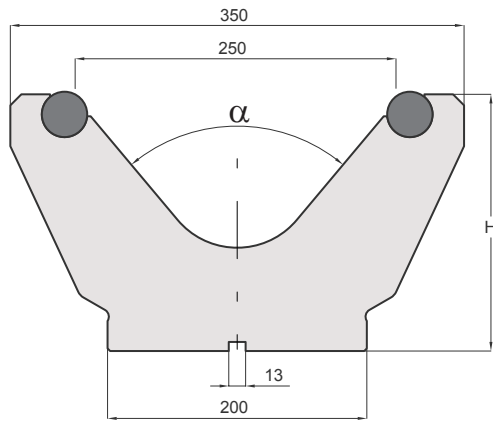

100 mm

CODE	$\alpha$	H	T/Mt	Mt
20.732	80°	250.00	200	■

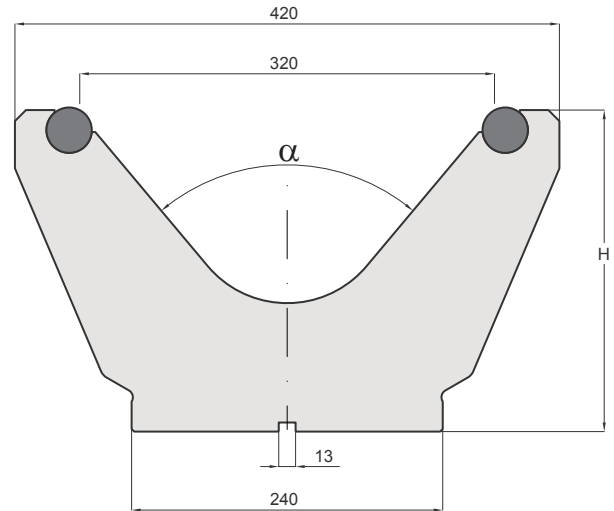

100 mm

CODE	L
20.701	100

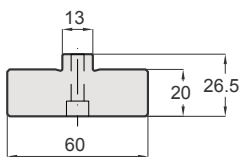

AMADA

CODE	L
20.707	100

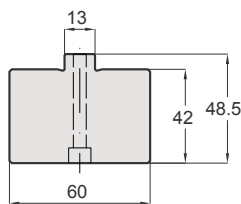

EHT

CODE	L
20.709	100

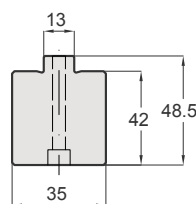

WEINBRENNER

CODE	L
20.705	100

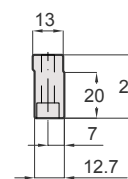

LVD

CODE	L
20.703	100



WILA - BYSTRONIC





# CONTENITORI E INSERTI IN POLIURETANO / HOLDERS AND POLYURETHANE INSERTS

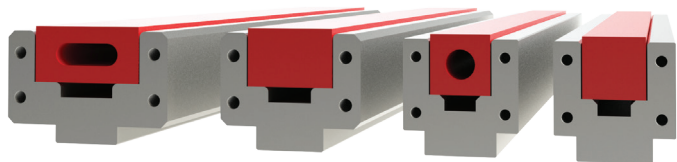

## CUSCINI IN POLIURETANO PIENI E FORATI CON RELATIVI CONTENITORI

### VANTAGGI :

EVITANO I SEGNI DI PIEGATURA  
 IDEALE PER PIEGARE ALLUMINIO, INOX E LAMIERE PREVERNICIATE  
 ADATTI A PIEGHE A V , RAGGIATE E A FORMA DI U

## POLYURETHANE INSERTS AND HOLDERS

### ADVANTAGES :

AVOIDS MARKS ON BENDED SHEETS  
 IDEAL FOR BENDING ALUMINIUM, STAINLESS STEEL AND PAINTED  
 SURFACES

SUITABLE FOR V, RADIUS AND U-BENDING

CODE	H
21.280	26.00

415 mm  
835 mm

INSERTO IN GOMMA PER MATRICE COD. 21.207  
 POLYURETHANE INSERT FOR DIE COD. 21.207

CODE	H
20.271	60.00

415 mm  
835 mm

CODE	H
20.272	96.00

415 mm  
835 mm

CODE	H
20.273	100.00

415 mm  
835 mm

CODE	H
20.274	100.00

415 mm  
835 mm

CODE	H
20.292	25.00

415 mm  
835 mm

CODE	H
20.291	50.00

415 mm  
835 mm

CODE	H
20.290	50.00

415 mm  
835 mm

CODE	H
20.289	50.00

415 mm  
835 mm

CODE	H
21.292	25.00

415 mm  
835 mm

CODE	H
21.291	50.00

415 mm  
835 mm

CODE	H
21.290	50.00

415 mm  
835 mm

CODE	H
21.289	50.00

415 mm  
835 mm

# CONTENITORI E INSERTI IN NYLON / NYLON INSERTS AND HOLDERS

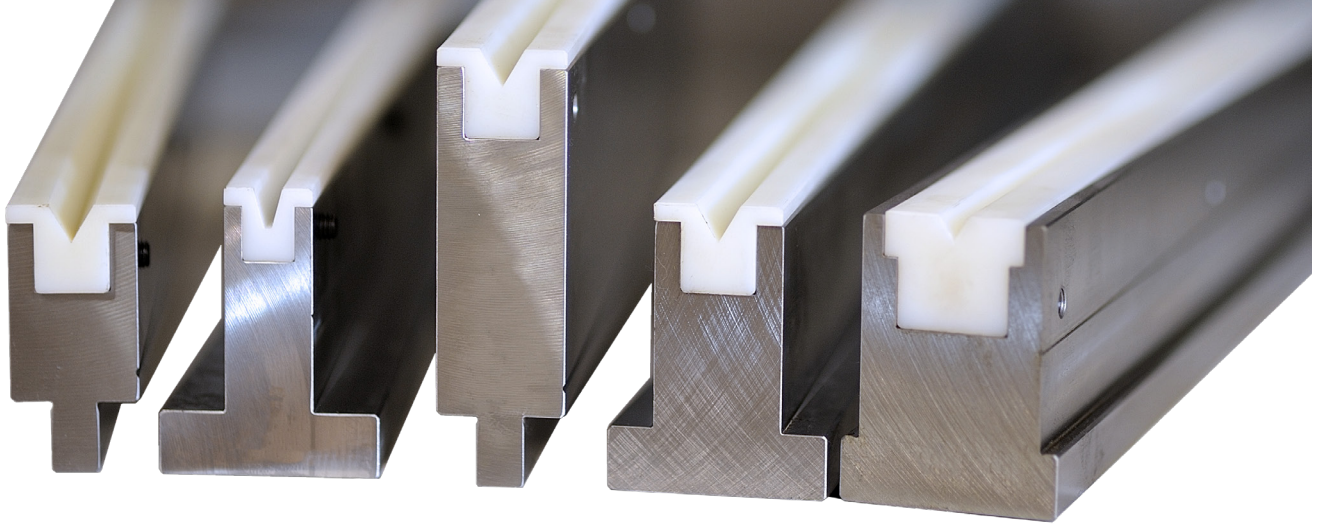

## INSERTI IN NYLON E RELATIVI CONTENITORI

### VANTAGGI :

- EVITANO I SEGNI DI PIEGATURA
- IDEALE PER PIEGARE ALLUMINIO, INOX E LAMIERE PREVERNICIATE
- CAMBIO FACILE E VELOCE

## NYLON INSERTS AND HOLDERS

### ADVANTAGES :

- AVOIDS MARKS ON BENDED SHEETS
- IDEAL FOR BENDING ALUMINIUM, STAINLESS STEEL AND PAINTED SURFACES
- FAST AND EASY CHANGE

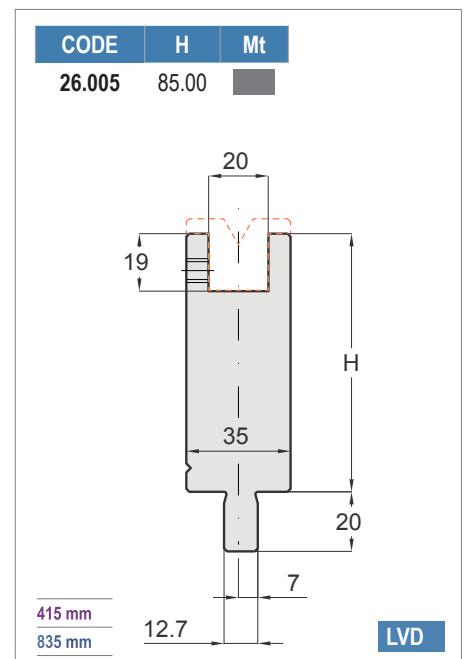
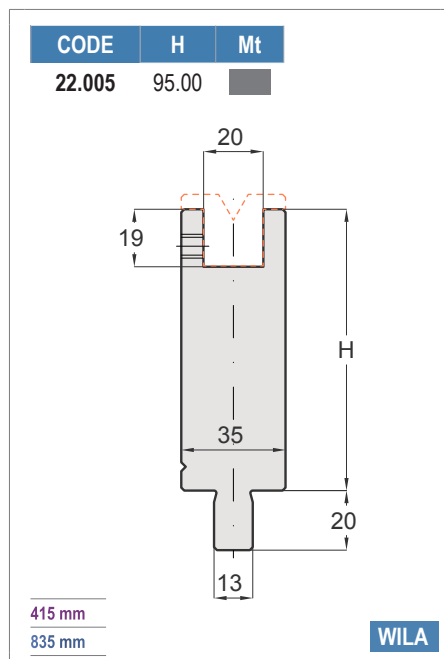
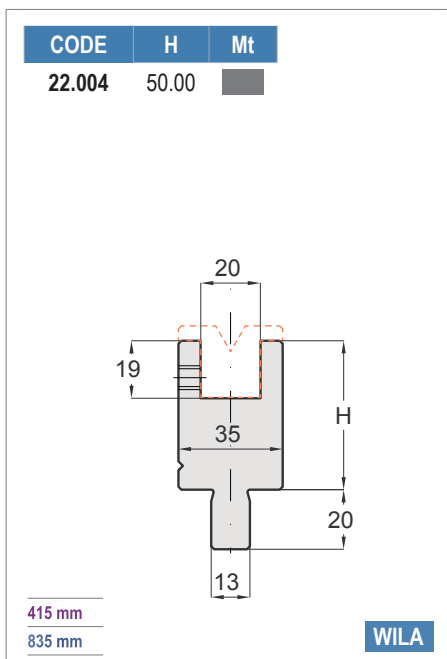
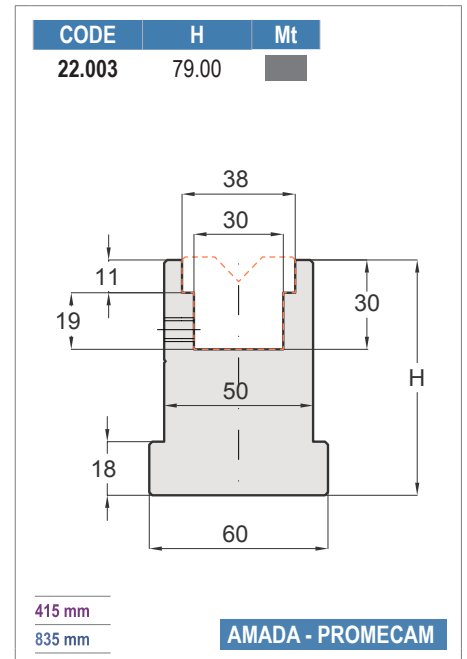
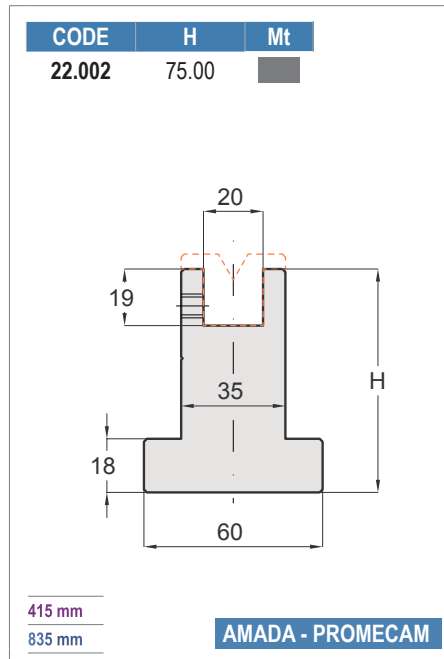
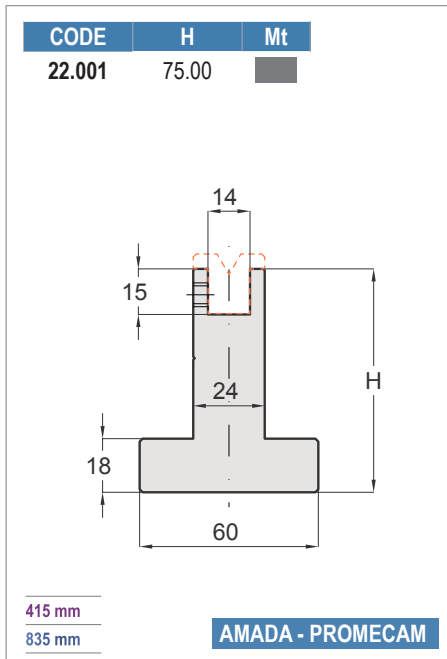

# INSERTI IN NYLON / NYLON INSERTS

CODE	$\alpha$	V	T/mt
31.306	30°	6	20
31.308	30°	8	20
31.406	45°	6	20
31.408	45°	8	20
31.410	45°	10	20
31.606	60°	6	20
31.608	60°	8	20
31.610	60°	10	20
31.806	88°	6	20
31.808	88°	8	20
31.810	88°	10	20

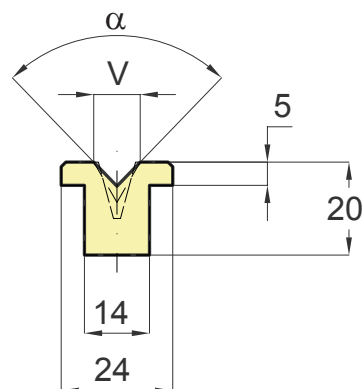

415 mm  
835 mm

CODE	$\alpha$	V	T/mt
32.306	30°	6	20
32.308	30°	8	20
32.310	30°	10	20
32.406	45°	6	20
32.408	45°	8	20
32.410	45°	10	20
32.412	45°	12	20
32.606	60°	6	20
32.608	60°	8	20
32.610	60°	10	20

CODE	$\alpha$	V	T/mt
32.612	60°	12	20
32.616	60°	16	20
32.806	88°	6	20
32.808	88°	8	20
32.810	88°	10	20
32.812	88°	12	20
32.816	88°	16	20

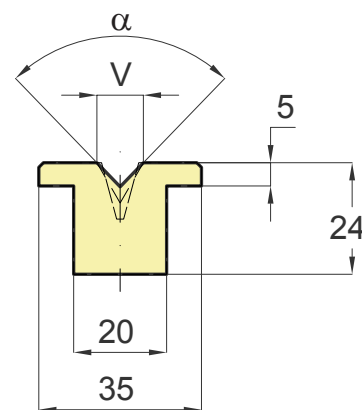

415 mm  
835 mm

CODE	$\alpha$	V	T/mt
33.306	30°	6	20
33.308	30°	8	20
33.310	30°	10	20
33.312	30°	12	20
33.316	30°	16	20
33.406	45°	6	20
33.408	45°	8	20
33.410	45°	10	20
33.412	45°	12	20
33.416	45°	16	20
33.420	45°	20	20
33.606	60°	6	20

CODE	$\alpha$	V	T/mt
33.608	60°	8	20
33.610	60°	10	20
33.612	60°	12	20
33.616	60°	16	20
33.620	60°	20	20
33.806	88°	6	20
33.808	88°	8	20
33.810	88°	10	20
33.812	88°	12	20
33.816	88°	16	20
33.820	88°	20	20
33.825	88°	25	20

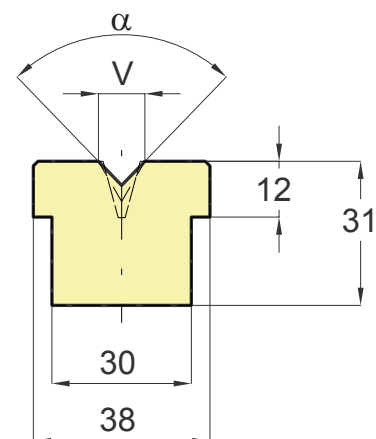

415 mm  
835 mm

# PELLICOLE ANTIGRAFFIO IN POLIURETANO / FILM OF POLYURETHANE ANTISCRATCH



<b>LEGENDA</b>	S= SPESSORE PELLICOLA	L= LARGHEZZA PELLICOLA	T= SPESSORE LAMIERA (mm)
<b>LEGEND</b>	S= FILM THICKNESS	L= FILM WIDTH	T= SHEET METAL THICKNESS (mm)

CODE	S	L
40.810	0.8	95

THICKNESS S=0.8

95

**LENGHT | 33 mt**

CODE	S	L
40.815	0.3	95

THICKNESS S=0.3

95

**LENGHT | 33 mt**

CODE	S	L
40.820	0.5	95

THICKNESS S=0.5

95

**LENGHT | 33 mt**

CODE	S	L
40.830	0.5	35

THICKNESS S=0.5

35

**LENGHT | 33 mt**

CODE	S	L
40.835	1.5	200

THICKNESS S=1.5

200

**LENGHT | 15 mt**

CODE	S	L
40.840	0.5	150

THICKNESS S=0.5

150

**LENGHT | 33 mt**

CODE	S	L
40.845	2	250

THICKNESS S=2

250

**LENGHT | 10 mt**

# TENDELLICOLA STANDARD E MAGNETICO / STANDARD AND MAGNETIC FILM HOLDER

CODE

40.800

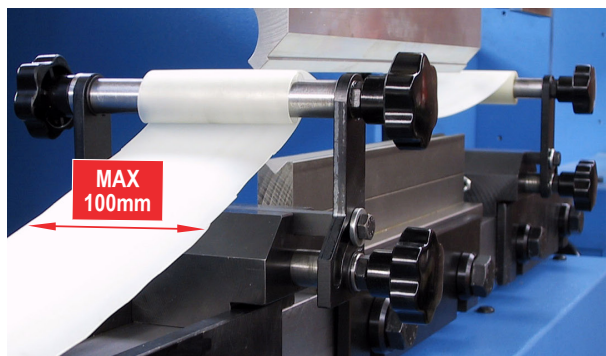
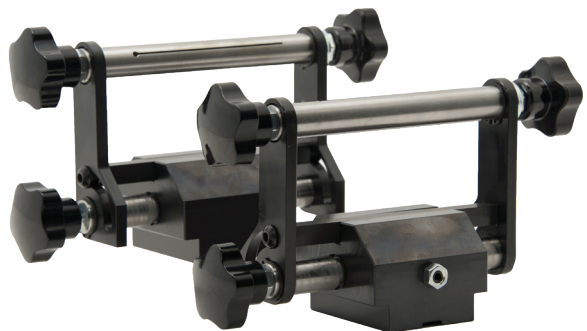

STANDARD SYSTEM

Max = 100mm

CODE

40.850



MAGNETIC SYSTEM

Max = 150mm

CODE

40.860



STANDARD SYSTEM

Max = 250mm

## TABELLA DI PIEGATURA BENDING CHART

CODE	S	T
40.810	0.8	1 mm to 3 mm
40.815	0.3	0.2 mm to 1 mm
40.820	0.5	0.5 mm to 1.5 mm
40.830	0.5	0.5 mm to 1.5 mm
40.835	1.5	2 mm to 4 mm
40.840	0.5	0.5 mm to 1.5 mm
40.845	2	3 mm to 6 mm

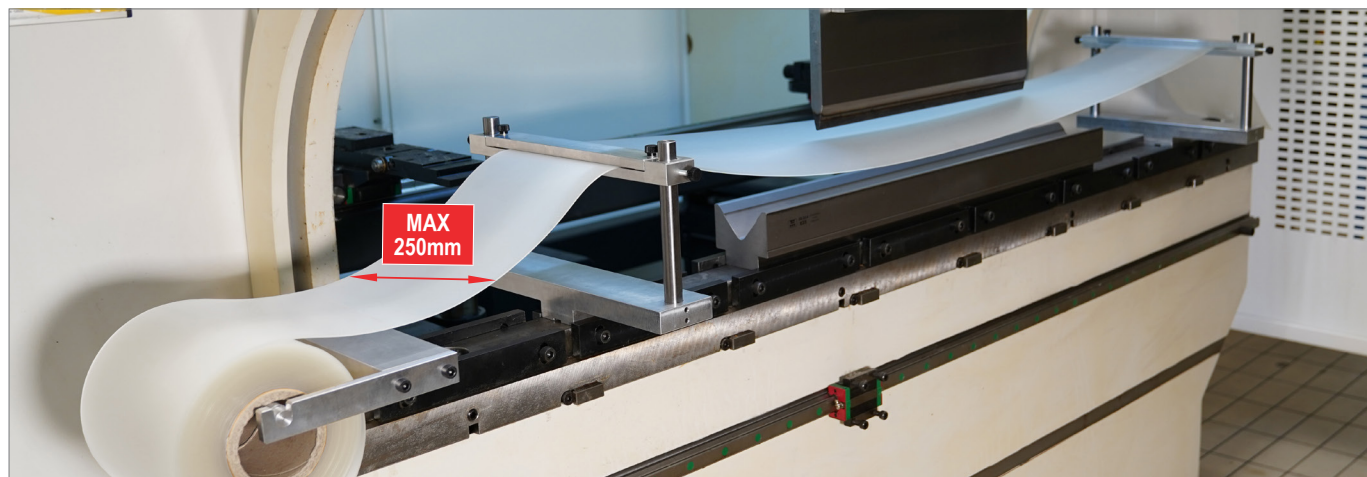

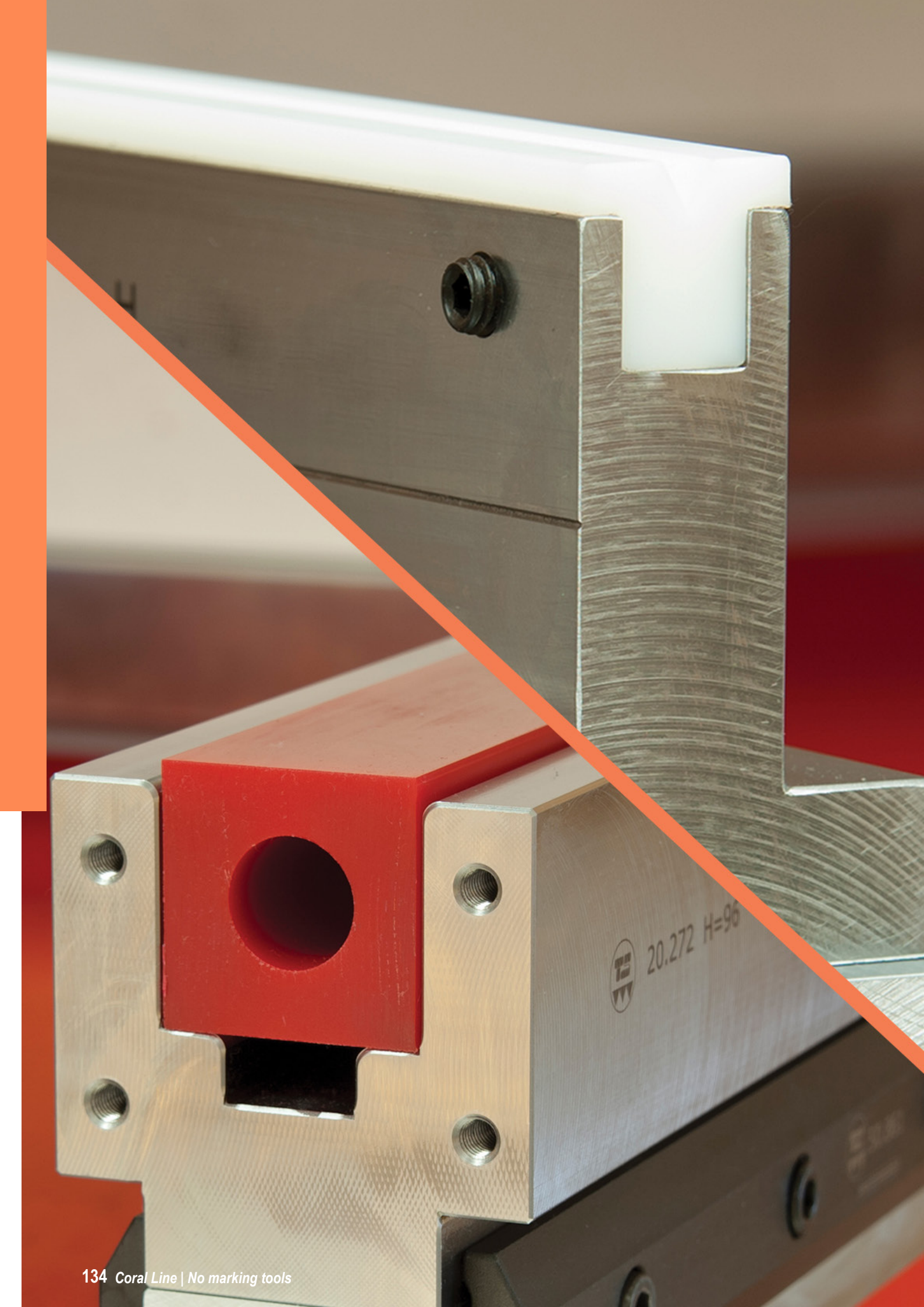

# MAGENTA LINE

ADATTATORI  
ADAPTERS

INTERMEDIARI  
INTERMEDIATES

CANALINE  
HOLDERS

INTERMEDIARIO RAPIDO MANUALE  
MANUAL FAST CLAMPING

STAFFE  
CLAMP PLATES

ADATTATORI INFERIORI  
LOWER ADAPTERS

INTERMEDIARI PNEUMATICI  
PNEUMATIC INTERMEDIATES



## MAGENTA LINE

*ADATTATORI PER TUTTE LE PRESSE*  
*ADAPTERS FOR ALL PRESS BRAKES*



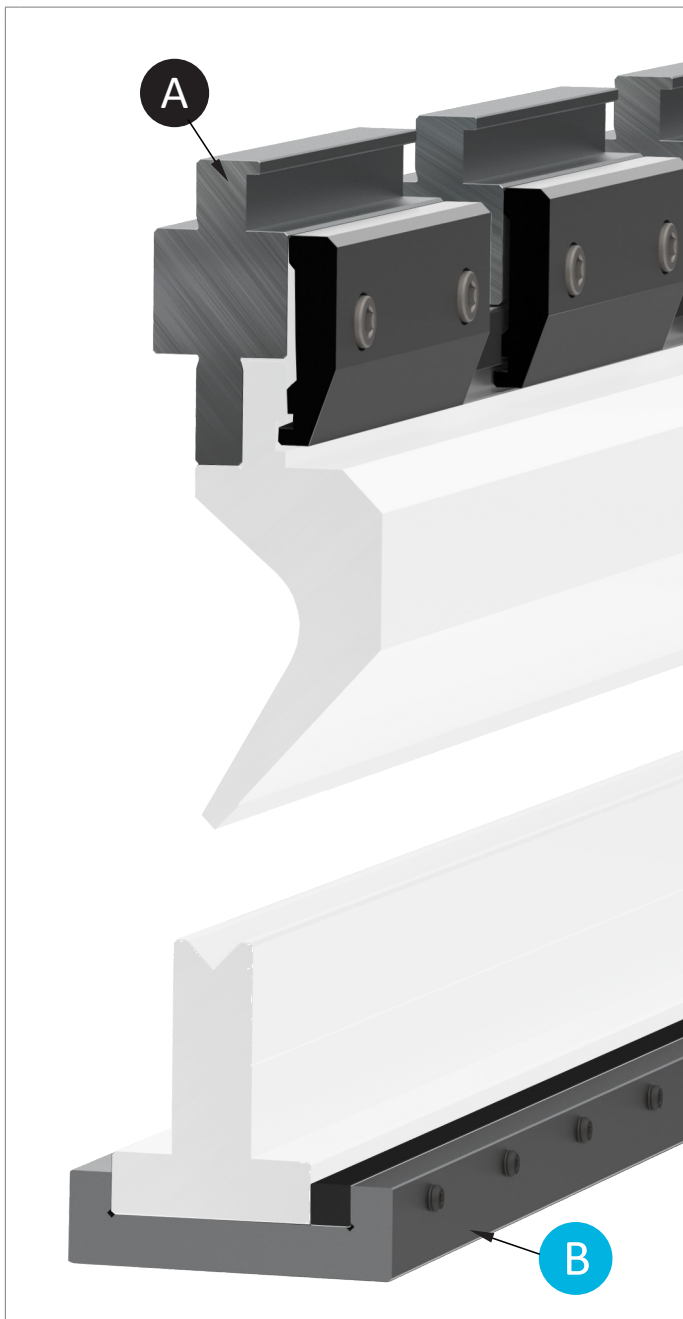

SPECIFICARE DIMENSIONE

SPECIFY DIMENSION

	1	2	Mt
A =			
B =			
C =			
D =			

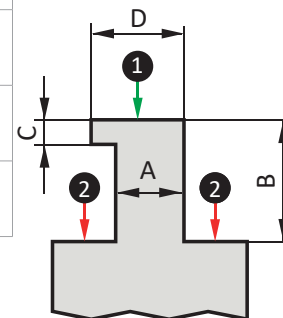

A

CODE	L	T/Mt	Mt
60.680	2100	100	■
60.681	2600	100	■
60.682	3100	100	■
60.683	4100	100	■

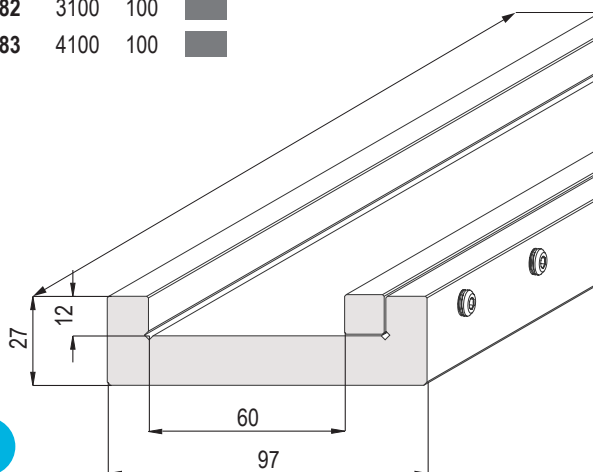

B

CODE	L	H	T/Mt	Mt
800.000	150	59.00	100	■

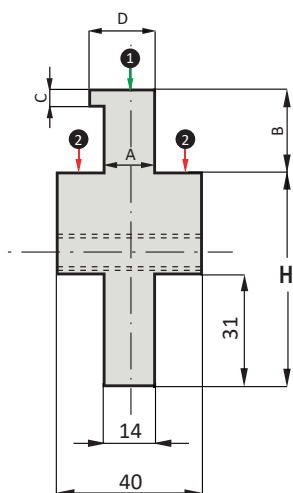

A

CODE	L	H	T/Mt	Mt
810.000	150	67.00	100	■

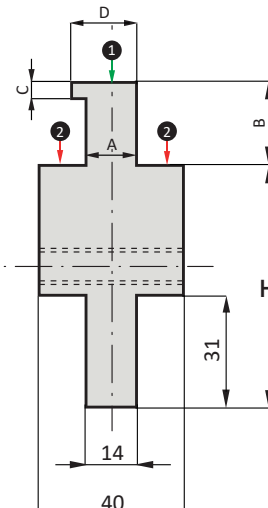

A

CODE	L	H	T/Mt	Mt
820.000	150	100.00	100	■

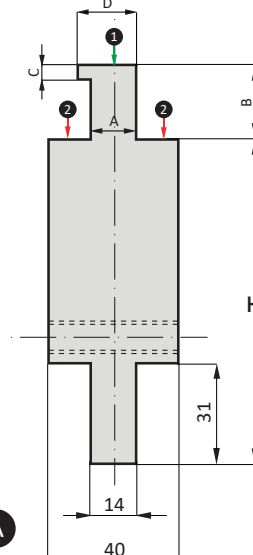

A



**STAFFE NON COMPRESSE / CLAMP PLATES NOT INCLUDED**

CODE	L	H	T/Mt	Mt
50.666	150	100.00	100	
50.668	150	120.00	100	
50.512	150	150.00	100	

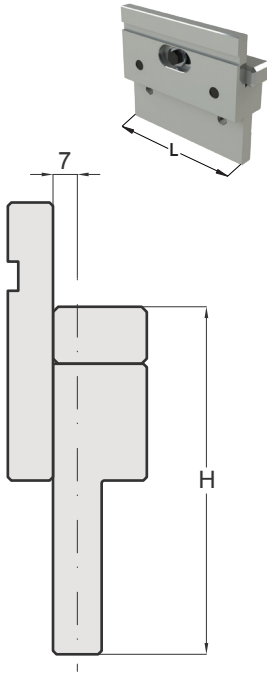

CODE	L	H	T/Mt	Mt
50.674	150	120.00	100	

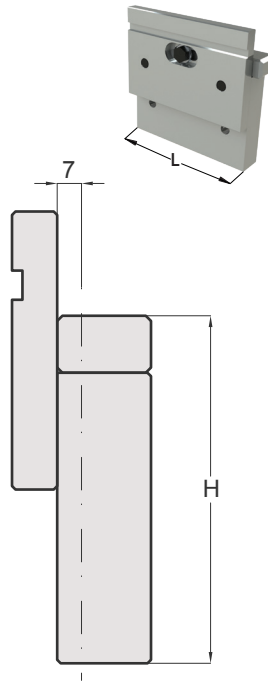

CODE	L	H	T/Mt	Mt
50.705	70	100.00	100	
50.706	70	120.00	100	
50.708	70	150.00	100	

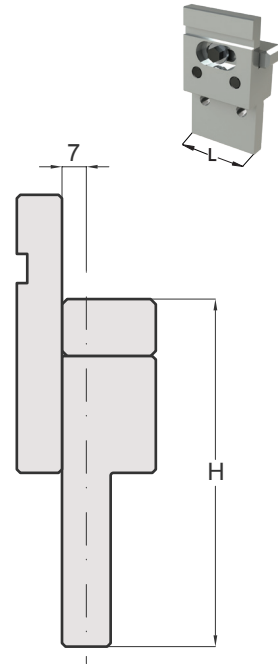

CODE	L	H	T/Mt	Mt
50.680	150	100.00	100	
50.667	150	120.00	100	
50.669	150	150.00	100	

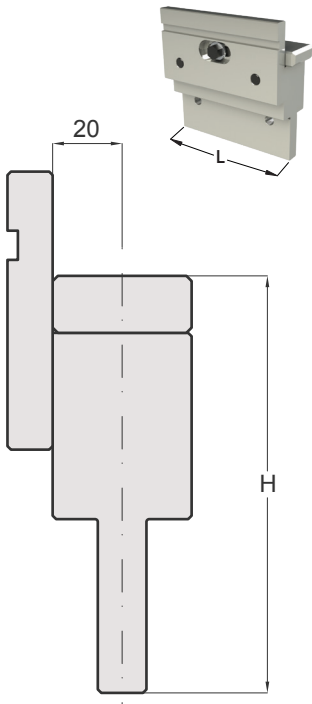

CODE	L	H	T/Mt	Mt
50.673	150	120.00	100	

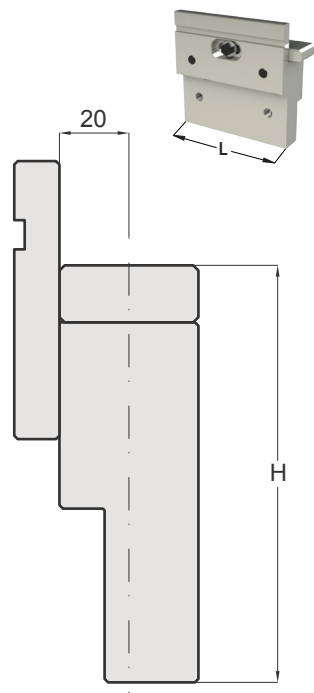

CODE	L	H	T/Mt	Mt
50.707	70	120.00	100	
50.710	70	150.00	100	

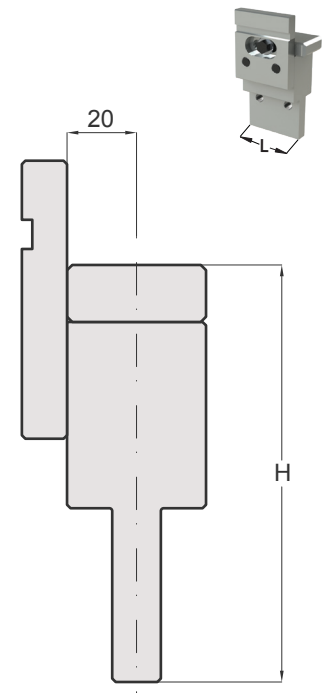

**PROLUNGHE E ADATTATORI / EXTENSIONS AND ADAPTERS**  
**STAFFE NON COMPRESI / CLAMP PLATES NOT INCLUDED**

CODE	L	H	T/Mt	Mt
50.959	150	60.00	100	■

PROLUNGA  
EXTENSION  
**AMADA**

CODE	L	H	T/Mt	Mt
50.671	150	100.00	100	■

PROLUNGA  
EXTENSION  
**AMADA**

CODE	L	H	T/Mt	Mt
50.430	150	67.00	100	■

ADATTATORE  
ADAPTER  
**AMADA / WILA**

CODE	L	H	T/Mt	Mt
50.970	150	83.00	100	■

ADATTATORE  
ADAPTER  
**WILA / AMADA**

CODE	L	H	T/Mt	Mt
50.971	150	80.00	100	■

ADATTATORE  
ADAPTER  
**WILA / AMADA**

CODE	L	H	T/Mt	Mt
50.940	150	120.00	100	■

ADATTATORE  
ADAPTER  
**WILA / AMADA**

CODE	L	H	T/Mt	Mt
50.410	150	100.00	100	■
50.415	50	100.00	100	■

PROLUNGA  
EXTENSION  
**WILA**

CODE	L	H	T/Mt	Mt
50.440	150	150.00	100	■
50.445	50	150.00	100	■

PROLUNGA  
EXTENSION  
**WILA**

CODE	L	H	T/Mt	Mt
50.450	150	63.00	100	■

ADATTATORE  
ADAPTER  
**EHT / WILA**

**PROLUNGHE E ADATTATORI / EXTENSIONS AND ADAPTERS**  
**STAFFE NON COMPRESI / CLAMP PLATES NOT INCLUDED**

CODE	L	H	T/Mt	Mt
50.470	150	65.00	100	■

ADATTATORE  
ADAPTER

**LVD / WILA**

CODE	L	H	T/Mt	Mt
50.490	150	65.00	100	■

ADATTATORE  
ADAPTER

**WEINBRENNER / WILA**

CODE	L	H	T/Mt	Mt
50.960	150	23.00	100	■

ADATTATORE  
ADAPTER

**USA / WILA**

CODE	L	H	T/Mt	Mt
50.981	150	67.00	100	■

ADATTATORE  
ADAPTER

**BYSTRONIC-S / AMADA**

CODE	L	H	T/Mt	Mt
50.980	150	67.00	100	■

ADATTATORE  
ADAPTER

**BYSTRONIC-R / AMADA**

CODE	L	H	T/Mt	Mt
50.983	150	100.00	100	■

ADATTATORE  
ADAPTER

**BYSTRONIC RF-A / AMADA**

CODE	L	H	T/Mt	Mt
50.985	150	100.00	100	■

PROLUNGA  
EXTENSION

**BYSTRONIC EURO**

CODE	L	H	T/Mt	Mt
50.982	150	101.00	100	■

PROLUNGA  
EXTENSION

**BYSTRONIC - R**

STAFFA INCLUSA  
CLAMP PLATE INCLUDED

CODE	L	H	T/Mt	Mt
50.400	150	100.00	100	■

PROLUNGA  
EXTENSION

**BYSTRONIC RF-A**

STAFFA INCLUSA  
CLAMP PLATE INCLUDED

# ADATTATORI / ADAPTERS

STAFFE NON COMPRESSE / CLAMP PLATES NOT INCLUDED

CODE	L	H	T/Mt	Mt
50.990	150	80.00	100	■

ADATTATORE  
ADAPTER

**LVD / AMADA**

CODE	L	H	T/Mt	Mt
50.992	150	67.00	100	■

ADATTATORE  
ADAPTER

**DURMAZLAR / AMADA**

CODE	L	H	T/Mt	Mt
50.994	150	100.00	100	■

ADATTATORE  
ADAPTER

**DARLEY / AMADA**

CODE	L	H	T/Mt	Mt
50.997	150	67.00	100	■

ADATTATORE  
ADAPTER

**DARLEY / AMADA**

CODE	L	H	T/Mt	Mt
50.996	150	89.00	100	■

ADATTATORE  
ADAPTER

**BAYKAL / AMADA**

CODE	L	H	T/Mt	Mt
50.998	150	67.00	100	■

ADATTATORE  
ADAPTER

**HACO / AMADA**

CODE	L	H	T/Mt	Mt
50.950	150	67.00	100	■

ADATTATORE  
ADAPTER

**USA / AMADA**

CODE	L	H	T/Mt	Mt
50.991	150	100.00	100	■

ADATTATORE  
ADAPTER

**EHT / AMADA**

CODE	L	H	T/Mt	Mt
50.993	150	100.00	100	■

ADATTATORE  
ADAPTER

**WEINBRENNER / AMADA**

**PROLUNGHE E ADATTATORI / EXTENSIONS AND ADAPTERS**  
**STAFFE INCLUSE / CLAMP PLATES INCLUDED**

CODE	L	H	T/Mt	Mt
50.930	150	100.00	100	■

ADATTATORE  
 ADAPTER  
**NEWTON / AMADA**

CODE	L	H	T/Mt	Mt
50.935	150	100.00	100	■

ADATTATORE  
 ADAPTER  
**AMADA / NEWTON**

CODE	L	H	T/Mt	Mt
50.500	200	220.00	90	■

PROLUNGA  
 EXTENSION  
**AMADA**

CODE	L	H	T/Mt	Mt
50.501	200	220.00	90	■

PROLUNGA  
 EXTENSION  
**AMADA**

**PROLUNGHE E ADATTATORI / EXTENSIONS AND ADAPTERS**  
**STAFFE INCLUSE / CLAMP PLATES INCLUDED**

CODE	L	H	T/Mt	Mt
50.502	200	220.00	90	■

ADATTATORE  
 ADAPTER  
**WILA / AMADA**

CODE	L	H	T/Mt	Mt
50.503	200	220.00	90	■

PROLUNGA  
 EXTENSION  
**WILA**

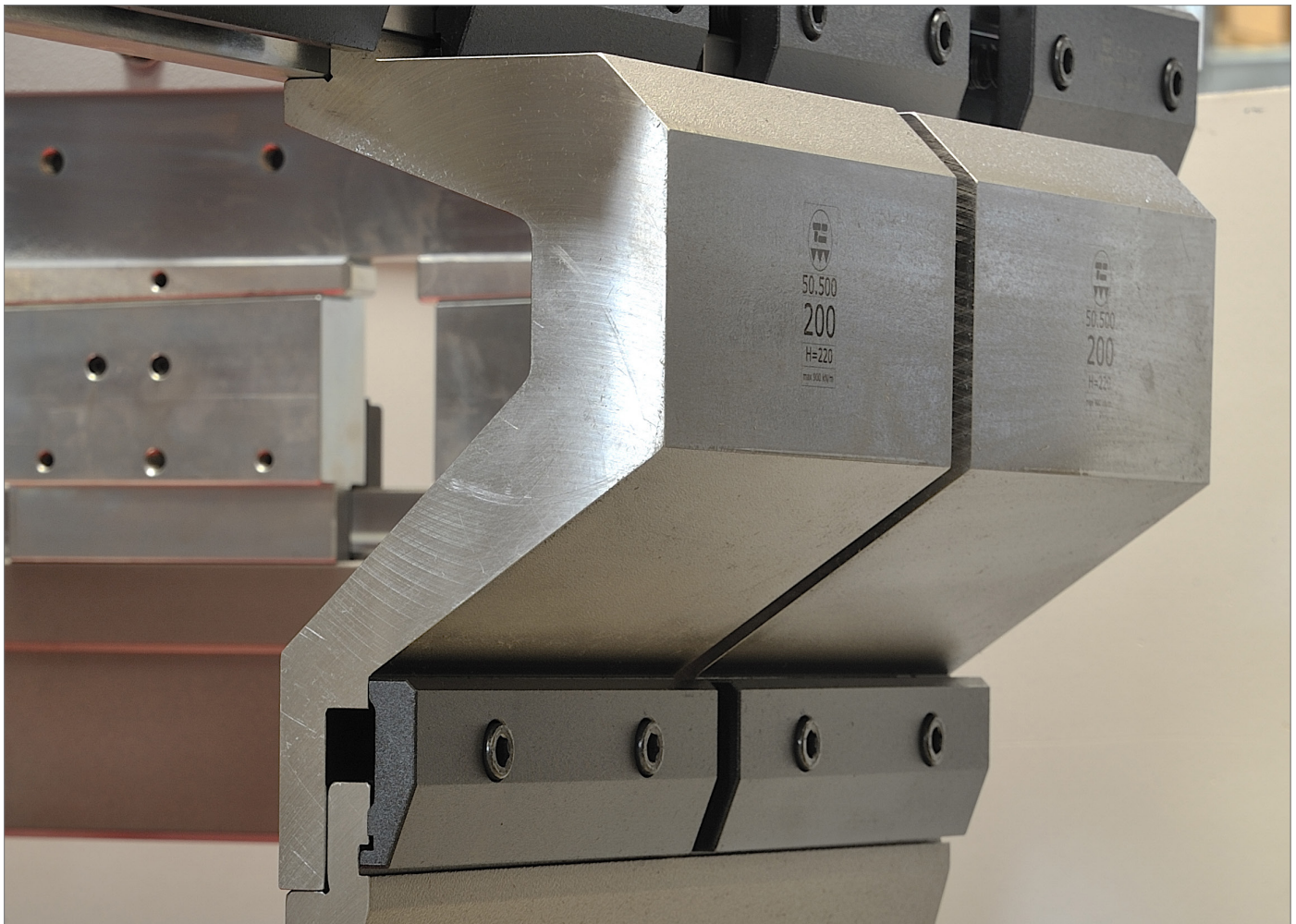

CODE	L	H	T/Mt	Mt
50.200	150	100.00	100	
50.210	150	120.00	100	
50.220	150	150.00	100	

AMADA - PROMECAM

CODE	L	H	T/Mt	Mt
50.250	150	150.00	100	

AMADA - PROMECAM

CODE	L	H	T/Mt	Mt
50.972	150	105.00	100	

WILA / AMADA

CODE	L	H	T/Mt	Mt
50.945	150	120.00	100	

WILA / AMADA

# STAFFE REGISTRABILI E FISSE / CLAMP PLATES FOR ADAPTERS

CODE	L	H
50.529	150	50.00

STAFFA  
CLAMP PLATE

CODE	L	H
50.571	150	60.00

STAFFA DI SICUREZZA  
SAFETY CLAMP PLATE

CODE	L	H
50.551	150	60.00

STAFFA DI SICUREZZA RAPIDA CON LEVETTA  
QUICK SAFETY CLAMP PLATE

CODE	L	H
50.900	150	60.00

STAFFA DI SICUREZZA CON LEVETTA A SCOMPARSA  
QUICK CLAMP PLATE WITH FOLDAWAY LEVER

CODE	L	H
50.910	150	60.00

STAFFA CON INSERTO IN POLIURETANO PER FRAZIONATI  
CLAMP WITH POLYURETHANE FOR SECTIONED TOP TOOLS

CODE	L	H
50.905	150	60.00

STAFFA RAPIDA CON INSERTO IN POLIURETANO PER FRAZIONATI  
QUICK CLAMP WITH POLYURETHANE FOR SECTIONED TOP TOOLS

CODE	L	H
50.903	150	60.00

STAFFA CON LEVETTA A SCOMPARSA ED INSERTO IN POLIURETANO  
QUICK CLAMP WITH FOLDAWAY LEVER AND POLYURETHANE

TCEI M10X70	71.100	TCEI M10X35

CODE		
50.574	50.551	50.529
50.577	50.905	50.571
		50.900
		50.910
		50.903
		50.310
		50.712
		50.697
		50.693





# STAFFE FISSE / CLAMP PLATES FOR ADAPTERS

CODE	L	H
50.310	150	45.00

STAFFA  
CLAMP PLATE

CODE	L	H
50.712	150	52.00

STAFFA DI SICUREZZA  
SAFETY CLAMP PLATE

CODE	L	H
50.697	70	50.00

STAFFA  
CLAMP PLATE

CODE	L	H
50.693	70	60.00

STAFFA DI SICUREZZA  
SAFETY CLAMP PLATE

# KIT PER DOPPIO STAFFAGGIO / EQUIPMENT FOR DOUBLE CLAMPING PLATE

CODE
50.574

KIT PER DOPPIO STAFFAGGIO  
EQUIPMENT FOR DOUBLE CLAMPING PLATE

CODE
50.577

KIT PER DOPPIO STAFFAGGIO  
EQUIPMENT FOR DOUBLE CLAMPING PLATE

# ADATTATORI INFERIORI / LOWER ADAPTERS

CODE	H	T/Mt	Mt
60.910	30.00	100	

50 mm  
100 mm  
200 mm  
300 mm  
500 mm  
1000 mm

ADATTATORE INFERIORE  
LOWER ADAPTER

**AMADA / WILA - BYSTRONIC**

CODE	H	T/Mt	Mt
60.920	60.00	100	

50 mm  
100 mm  
200 mm  
300 mm  
500 mm  
1000 mm

ADATTATORE INFERIORE  
LOWER ADAPTER

**AMADA / WILA - BYSTRONIC**

CODE	H	T/Mt	Mt
60.925	40.00	100	

415 mm  
835 mm

ADATTATORE INFERIORE  
LOWER ADAPTER

**WILA - BYSTRONIC / AMADA**

CODE	H	T/Mt	Mt
60.935	30.00	100	

50 mm  
100 mm  
200 mm  
300 mm  
500 mm  
1000 mm

ADATTATORE INFERIORE  
LOWER ADAPTER

**LVD / WILA - BYSTRONIC**

CODE	L	H	T/Mt	Mt
60.940	500	40.00	100	

ADATTATORE INFERIORE  
LOWER ADAPTER

**EHT / WILA**

CODE	L	H	T/Mt	Mt
60.950	500	45.00	100	

ADATTATORE INFERIORE  
LOWER ADAPTER

**WEINBRENNER / WILA**

CODE	H	T/Mt	Mt
60.930	40.00	100	

415 mm  
835 mm

ADATTATORE INFERIORE  
LOWER ADAPTER

**LVD / AMADA**

CODE	H	T/Mt	Mt
60.919	55.00	100	

415 mm  
835 mm

PROLUNGA  
EXTENSION

**AMADA - PROMECAM**

CODE	L	H	T/Mt	Mt
60.960	500	50.00	100	

PROLUNGA  
EXTENSION

**WILA**

# ADATTATORI INFERIORI / LOWER ADAPTERS

CODE	L	H	T/Mt	Mt
60.965	500	85.00	100	■

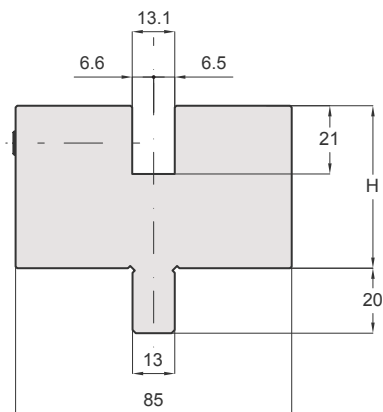
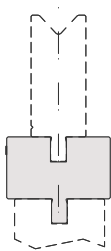

PROLUNGA  
EXTENSION

WILA

CODE	H	T/Mt	Mt
60.980	35.00	100	■

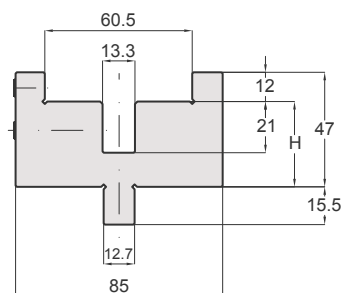
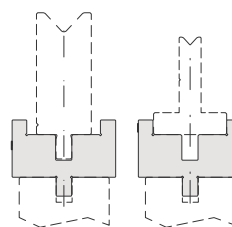

415 mm

835 mm

ADATTATORE INFERIORE  
LOWER ADAPTER

USA / EU - WILA - AMADA

CODE	H	T/Mt	Mt
60.945	60.00	100	■

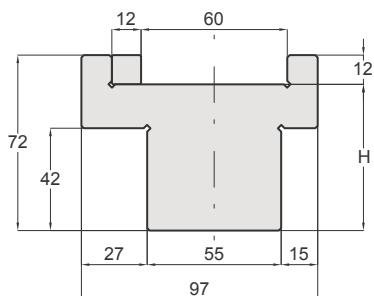
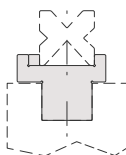

415 mm

835 mm

ADATTATORE INFERIORE  
LOWER ADAPTER

EHT / AMADA

CODE	H	T/Mt	Mt
60.955	65.00	100	■

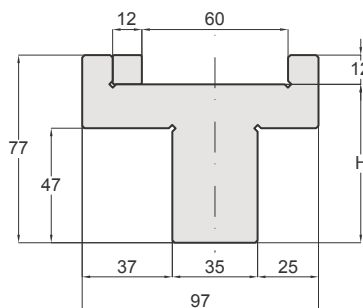
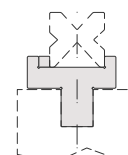

415 mm

835 mm

ADATTATORE INFERIORE  
LOWER ADAPTER

WEINBRENNER / AMADA

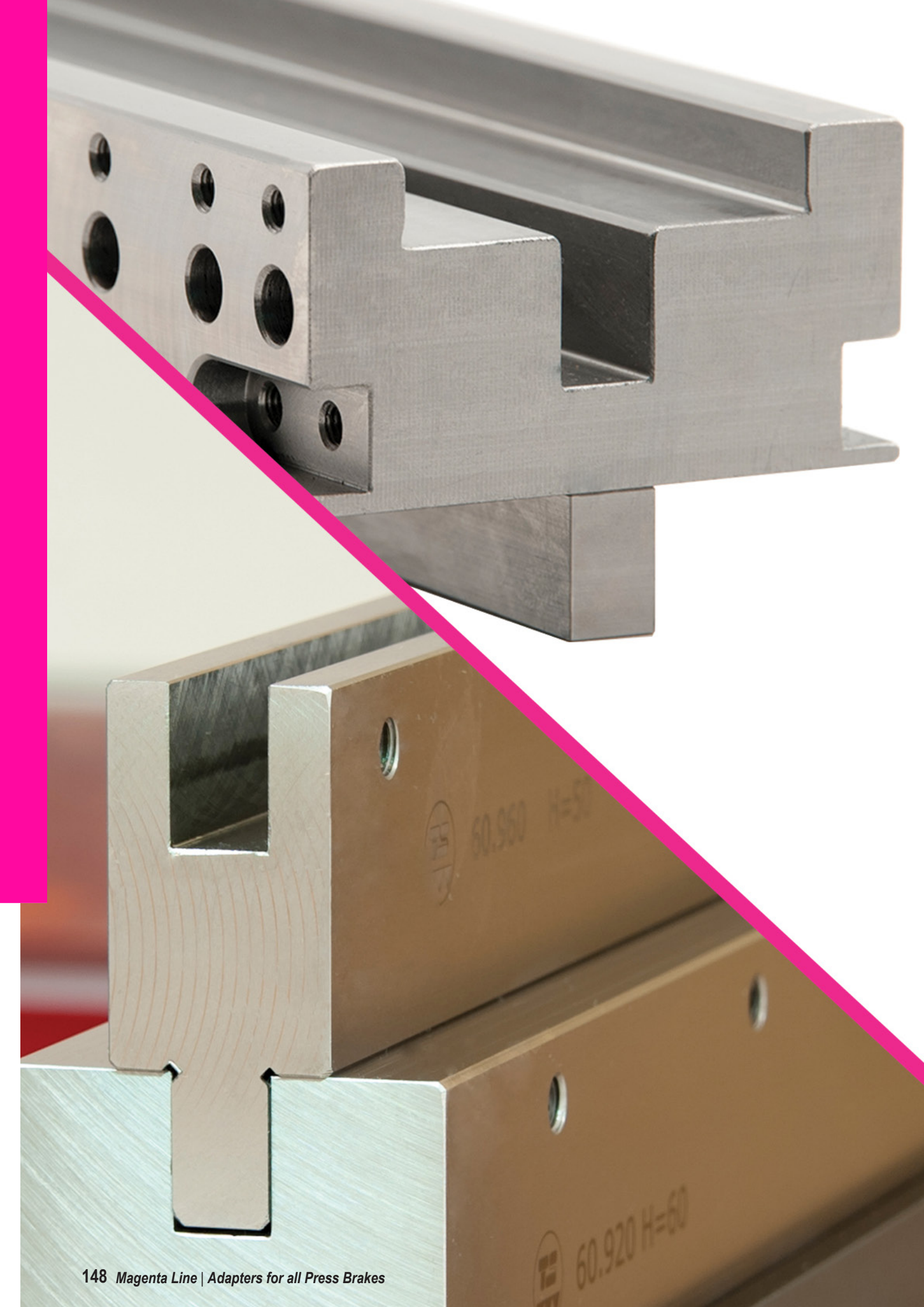

60.920 H=60

60.960 H=50

# CANALINE MODULARI / MODULAR HOLDERS

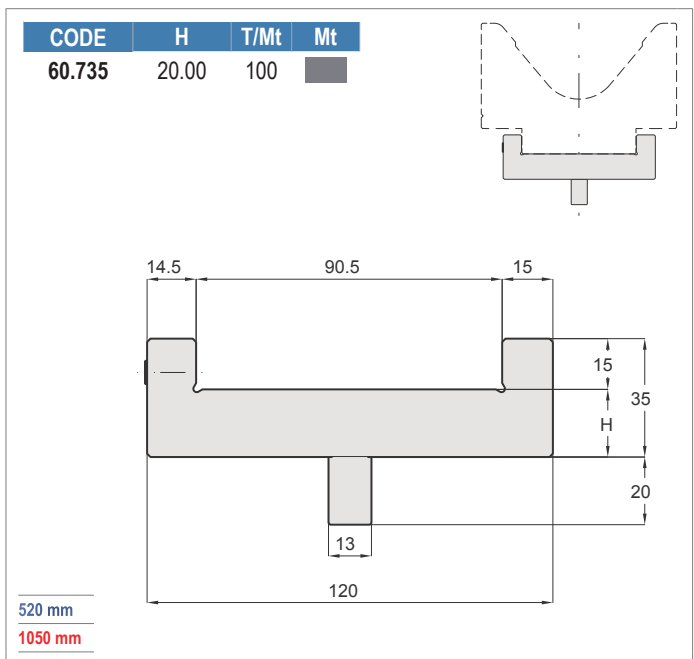
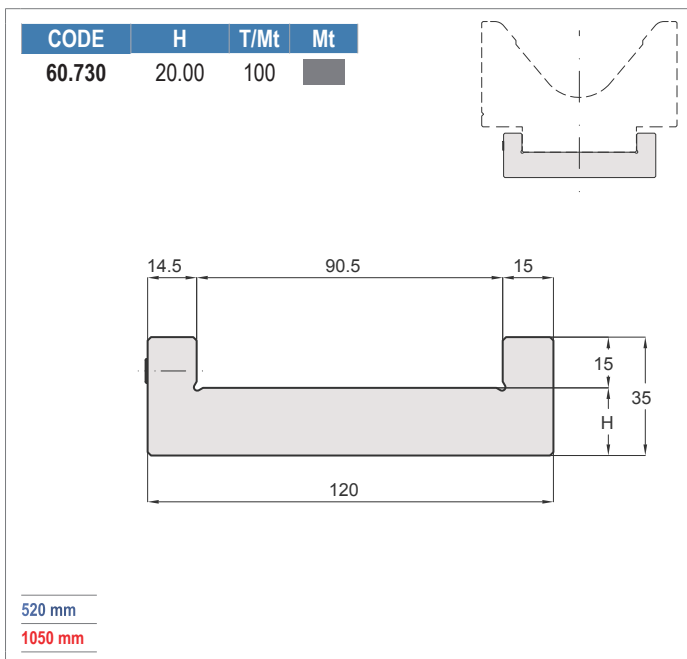
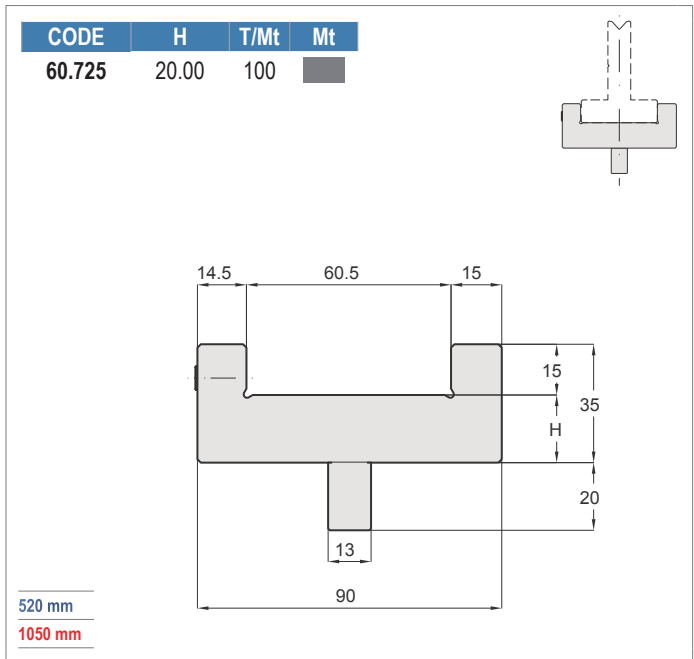
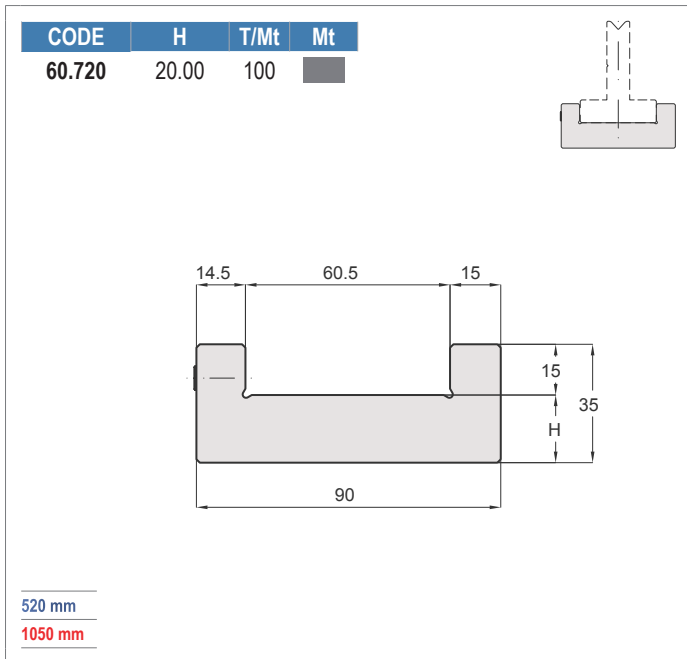
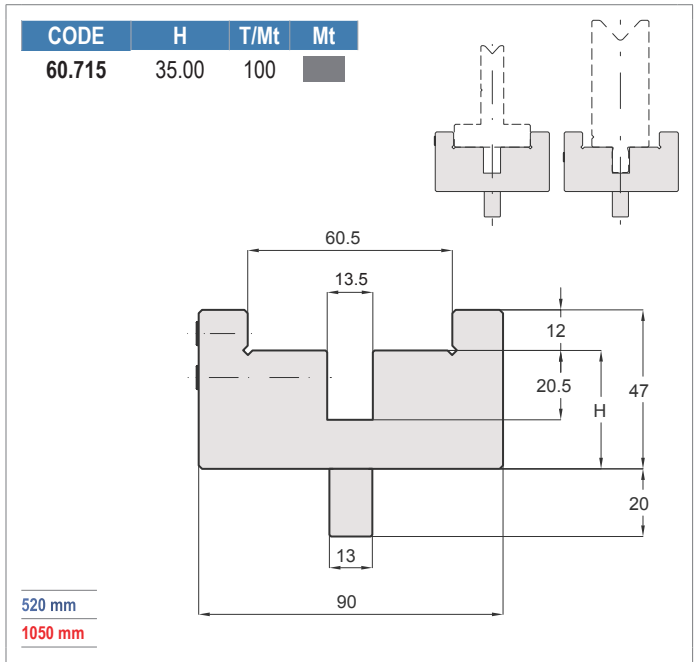
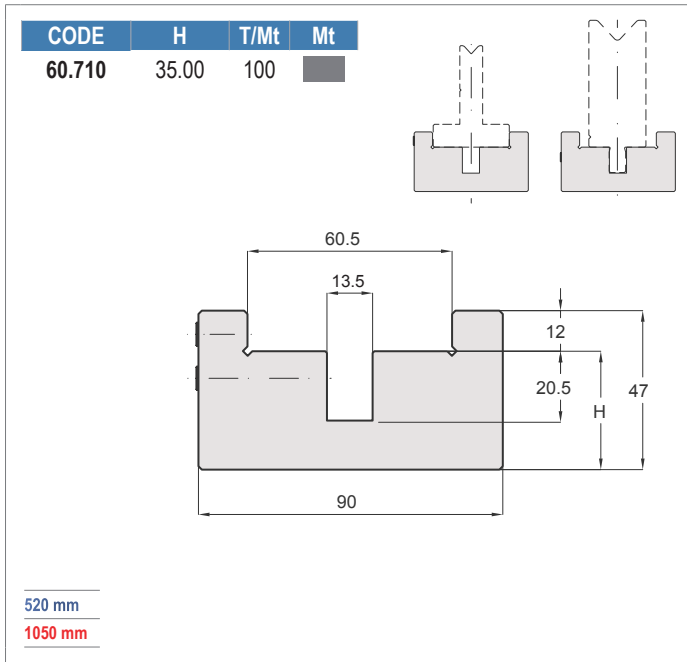

# RAPID MONTAGGIO LATERALE / SIDE INSTALLATION

SERIE "RAPID" - PER UTENSILI SUPERIORI CON SCANALATURA AMADA 8.4X3mm (70.946)

"RAPID" SERIES - FOR UPPER TOOLS ONLY WITH AMADA SAFETY GROOVE 8.4X3mm (70.946)

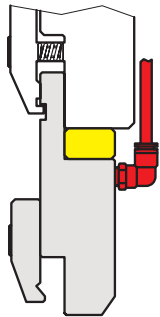

RAPID

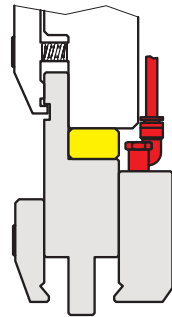

RAPID REVERS.

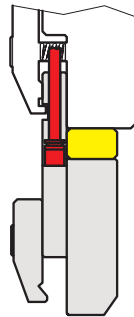

RAPID "FP"

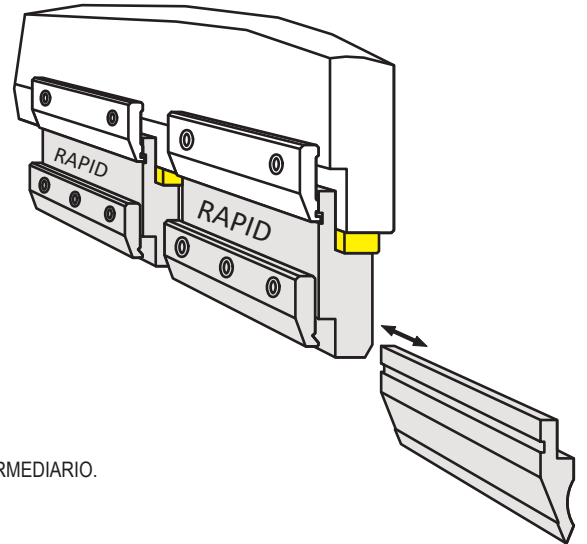

INTERMEDIARIO PNEUMATICO CENTINABILE.  
 BLOCCAGGIO PNEUMATICO/SBLOCCAGGIO MECCANICO.  
 MONTAGGIO E SMONTAGGIO LATERALE DEGLI UTENSILI.  
 L'UTENSILE VIENE PORTATO AUTOMATICAMENTE IN BATTUTA CONTRO IL CORPO DELL'INTERMEDIARIO.  
 TUBI DI COLLEGAMENTO AD INNESTO RAPIDO COMMERCIALI.

ADJUSTABLE PNEUMATIC ADAPTER.

PNEUMATIC CLAMPING/MECHANICAL UNCLAMPING.

SIDE INSTALLATION/DISINSTALLATION OF TOOLS.

THE TOOLS ARE AUTOMATICALLY POSITIONED AND CENTERED.

FAST COUPLING CONNECTIONS AND ITS JOINING PIPES AVAILABLE ON THE MARKET.

**APERTO**  
**OPEN**

CORSA = 1mm  
STROKE = 1 mm

Scanalatura di sicurezza  
standard 8.4x3 (AMADA)  
Standard safety groove  
8.4x3 (AMADA)

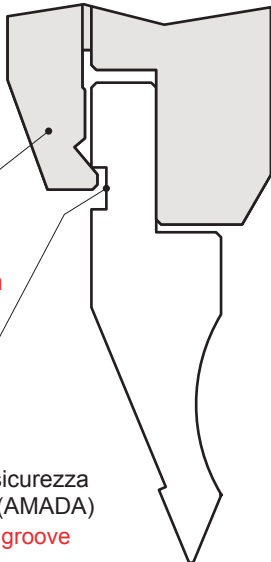

**CHIUSO**  
**CLOSED**

FORZA DI BLOCCAGGIO A 10 BAR=700 kg  
CLAMPING POWER AT 10 BARS = 700 Kg

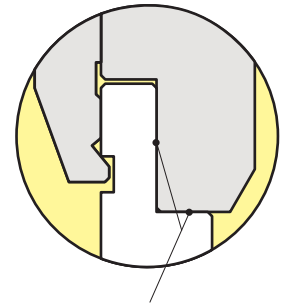

Punzone automaticamente  
posizionato e centrato.  
Tool automatically positioned  
and centered.

CENTRALINA PNEUMATICA  
PNEUMATIC EQUIPMENT

**50.650**  
A 1 COMANDO  
ONE CONTROL

**50.651**  
A 2 COMANDI  
TWO CONTROLS

CODE	A	H	T/Mt	Mt
50.800	7	100.00	100	■
50.805	7	120.00	100	■
50.810	7	150.00	100	■

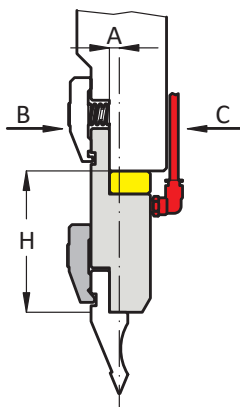

RAPID

CODE	A	H	T/Mt	Mt
50.870	7	100.00	100	■
50.875	7	150.00	100	■
50.890	20	120.00	100	■

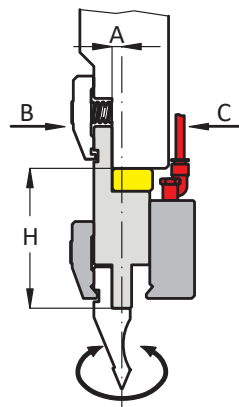

RAPID REVERSIBLE

CODE	A	H	T/Mt	Mt
50.820	7	100.00	100	■
50.825	7	150.00	100	■
50.830	20	120.00	100	■
50.835	20	150.00	100	■

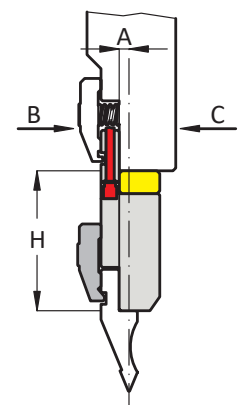

RAPID "FP"

# CLARK MONTAGGIO FRONTALE / FRONT INSTALLATION

SERIE "CLARK" - PER UTENSILI SUPERIORI CON SCANALATURA DI SICUREZZA DOPPIA (70.1050)

"CLARK" SERIES - FOR UPPER TOOLS ONLY WITH DOUBLE SAFETY GROOVE (70.1050)

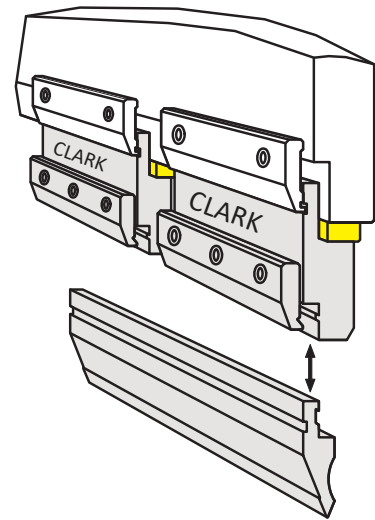
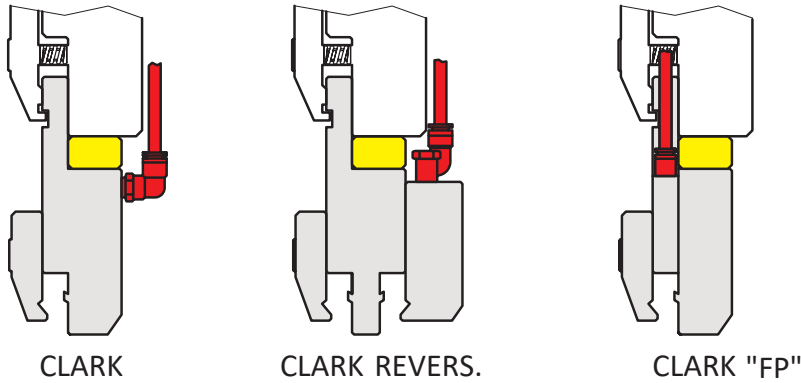

INTERMEDIARIO PNEUMATICO CENTINABILE.  
 BLOCCAGGIO PNEUMATICO/SBLOCCAGGIO MECCANICO.  
 MONTAGGIO E SMONTAGGIO FRONTALE DEGLI UTENSILI.  
 L'UTENSILE VIENE PORTATO AUTOMATICAMENTE IN BATTUTA CONTRO IL CORPO DELL'INTERMEDIARIO.  
 TUBI DI COLLEGAMENTO AD INNESTO RAPIDO COMMERCIALI.

ADJUSTABLE PNEUMATIC ADAPTER.  
 PNEUMATIC CLAMPING/MECHANICAL UNCLAMPING.  
 FRONT INSTALLATION/DISINSTALLATION OF TOOLS.  
 THE TOOLS ARE AUTOMATICALLY POSITIONED AND CENTERED.  
 FAST COUPLING CONNECTIONS AND ITS JOINING PIPES AVAILABLE ON THE MARKET.

**APERTO  
OPEN**

CORSA = 1mm  
STROKE = 1 mm

Scanalatura di sicurezza standard 8.4x3 (AMADA)  
Standard safety groove 8.4x3 (AMADA)

Scanalatura supplementare cod. 70.1050 per montare il punzone frontalmente  
Additional groove cod. 70.1050

**CHIUSO  
CLOSED**

FORZA  
DI BLOCCAGGIO A 10 BAR=700 kg  
CLAMPING POWER AT 10 BARS = 700 Kg

Dentello anticaduta di sicurezza  
Safety tooth

Punzone automaticamente posizionato e centrato.  
Tool automatically positioned and centered.

CENTRALINA PNEUMATICA  
PNEUMATIC EQUIPMENT

**50.650**  
A 1 COMANDO  
ONE CONTROL

**50.651**  
A 2 COMANDI  
TWO CONTROLS

CODE	A	H	T/Mt	Mt
50.600	7	100.00	100	■
50.610	7	120.00	100	■
50.615	7	150.00	100	■
50.640	20	120.00	100	■
50.646	20	150.00	100	■

**CLARK**

CODE	A	H	T/Mt	Mt
50.730	7	100.00	100	■
50.725	7	150.00	100	■
50.731	20	120.00	100	■

**CLARK REVERSIBLE**

CODE	A	H	T/Mt	Mt
50.635	7	100.00	100	■
50.685	7	150.00	100	■
50.645	20	120.00	100	■
50.657	20	150.00	100	■

**CLARK "FP"**

# ADATTATORI PNEUMATICI / PNEUMATIC ADAPTERS

CODE	S	A	CODE	CODE
63.121	15x15	90	60.685	63.000
63.122	30x15	120	Z	K
63.123	45x15	150		
63.124	60x15	180		

STAFFA PNEUMATICA INDIPENDENTE PER TAVOLE CON FORATURA AMADA  
PNEUMATIC FREE STANDING CLAMP FOR AMADA PRESS-BRAKES LOWER TABLES

CODE	S	A	CODE	CODE
63.126	13x15	90	63.012	63.001
63.127	27x15	120	Z	K
63.128	42x15	150		
63.129	57x15	180		

STAFFA PNEUMATICA INDIPENDENTE PER TAVOLE SCANALATE  
PNEUMATIC FREE STANDING CLAMP FOR GROOVED LOWER TABLES

**CODE**  
60.691

SCHEMA DI MONTAGGIO - ASSEMBLY SCHEME

415 mm

835 mm

RIALZO PORTAMATRICE MODULARE A BLOCCAGGIO PNEUMATICO E SBLOCCAGGIO A MOLLA.  
MODULAR HOLDER, PNEUMATIC CLAMPING SPRING UNCLAMPING.

**CODE**  
50.650

CENTRALINA PNEUMATICA AD 1 COMANDO  
PNEUMATIC EQUIPMENT WITH 1 CONTROL

**CODE**  
50.651

CENTRALINA PNEUMATICA A 2 COMANDI  
PNEUMATIC EQUIPMENT WITH 2 CONTROLS



# YELLOW LINE

LAME RETTILINEE PER CESCOIA  
RECTILINEAR SHEAR BLADES

1 / 2 / 4 TAGLIENTI  
1 / 2 / 4 CUTTING EDGES

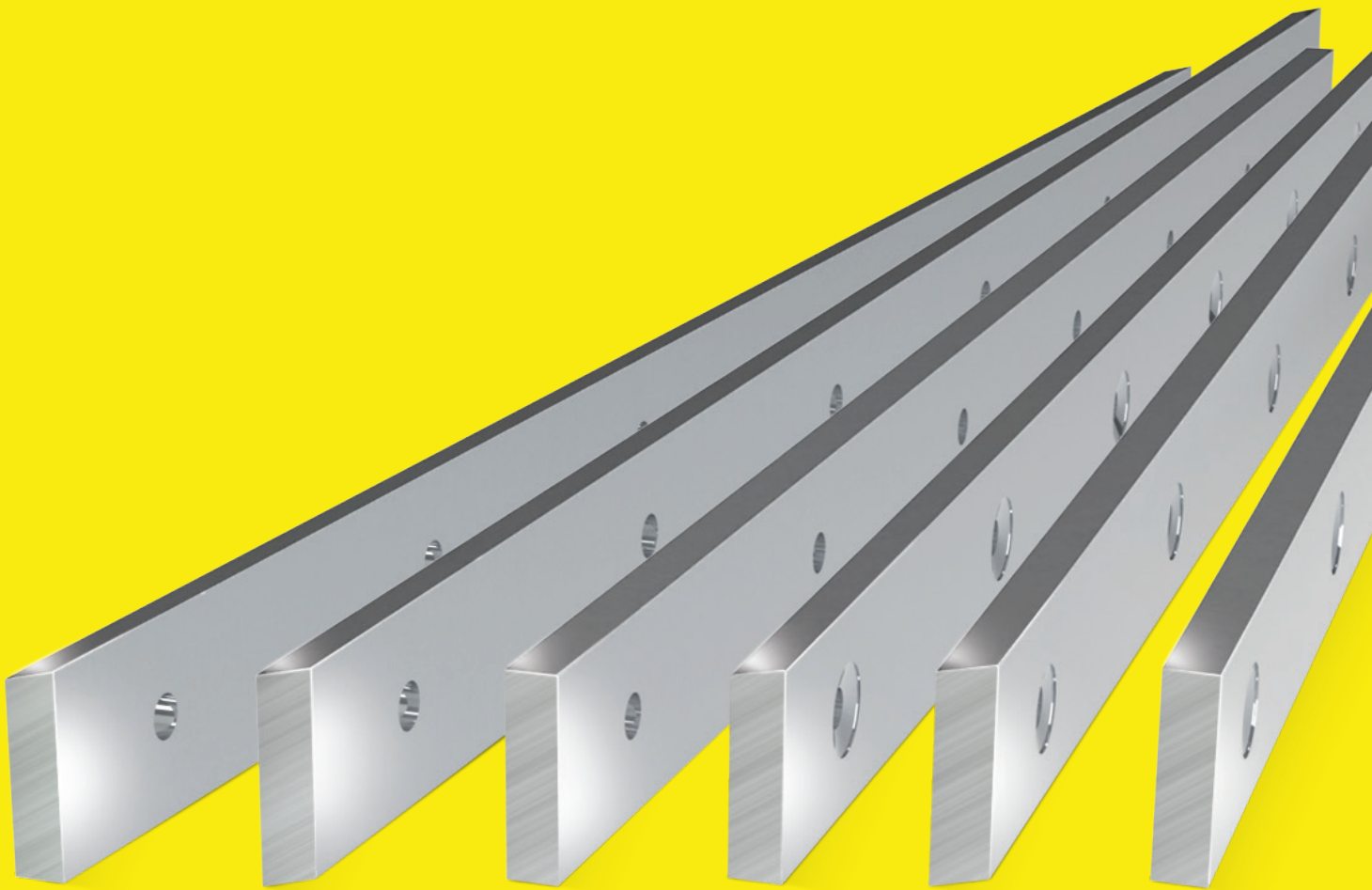

## YELLOW LINE

LAME PER CESCOIA  
SHEAR BLADES



# LAME PER CESOIA / SHEAR BLADES

LE LAME SONO ADATTE AL TAGLIO DI LAMIERA CON RESISTENZA FINO A 750 kN/mm<sup>2</sup>  
 THE BLADES ARE SUITABLE FOR CUTTING SHEETS METAL WITH RESISTANCE UP TO 750 kN/mm<sup>2</sup>

**1 SHARP**

SPECIFICARE DIMENSIONI  
 SPECIFY DIMENSIONS

A = .....  
 B = .....  
 C = .....  
 D = .....  
 E = .....

LAMA SUPERIORE / INFERIORE A 1 TAGLIENTE  
 BLADE UPPER / LOWER - 1 CUTTING EDGE WITH THREADED HOLE

LEGENDA	A = LUNGHEZZA	B = ALTEZZA	C = DISTANZA TRA I FORI	D = DIAMETRO FORI
LEGEND	A = LENGHT	B = HEIGHT	C = DISTANCE BETWEEN HOLES	D = DIAMETER HOLES

**2 SHARP**

SPECIFICARE DIMENSIONI  
 SPECIFY DIMENSIONS

A = .....  
 B = .....  
 C = .....  
 D = .....  
 E = .....

LAMA SUPERIORE / INFERIORE A 2 TAGLIENTI  
 BLADE UPPER / LOWER - 2 CUTTING EDGES WITH THREADED HOLE

LEGENDA	A = LUNGHEZZA	B = ALTEZZA	C = DISTANZA TRA I FORI	D = DIAMETRO FORI
LEGEND	A = LENGHT	B = HEIGHT	C = DISTANCE BETWEEN HOLES	D = DIAMETER HOLES

**4 SHARP**

SPECIFICARE DIMENSIONI  
 SPECIFY DIMENSIONS

A = .....  
 B = .....  
 C = .....  
 D = .....  
 E = .....

LAMA SUPERIORE / INFERIORE A 4 TAGLIENTI  
 BLADE UPPER / LOWER - 4 CUTTING EDGES WITH THREADED HOLE

LEGENDA	A = LUNGHEZZA	B = ALTEZZA	C = DISTANZA TRA I FORI	D = DIAMETRO FORI
LEGEND	A = LENGHT	B = HEIGHT	C = DISTANCE BETWEEN HOLES	D = DIAMETER HOLES

# GREEN LINE

SQUADRE DI RIFERIMENTO STANDARD E MAGNETICHE  
STANDARD AND MAGNETICS SQUARING ARMS

RIFERIMENTI E ARRESTI MICROMETRICI  
FRONT REFERENCE AND TRIP STOP WITH MICROMETER ADJUSTMENT

GONIOMETRO DIGITALE E KIT PROTEZIONE E PULIZIA  
DIGITAL ANGLE GAUGES AND CLEANING KIT

ARMADIO PORTAUTENSILI AMADA / WILA / TRUMPF / BYSTRONIC / LVD  
TOOLING CABINET AMADA / WILA / TRUMPF / BYSTRONIC / LVD



## GREEN LINE

ACCESSORI PER TUTTE LE PRESSE  
ACCESSORIES FOR ALL PRESS BRAKES



# ACCESSORI PER TUTTE LE PRESSE / ACCESSORIES FOR ALL PRESS BRAKES

CODE

40.740



SQUADRA DI RIFERIMENTO MAGNETICA 0° - 90°  
MAGNETIC SQUARING ARM 0° - 90°

SINISTRA  
LEFT

CODE

40.745

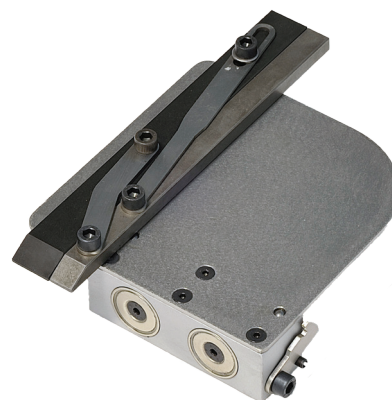

SQUADRA DI RIFERIMENTO MAGNETICA 0° - 90°  
MAGNETIC SQUARING ARM 0° - 90°

DESTRA  
RIGHT

CODE

40.660



SQUADRA DI RIFERIMENTO STANDARD FISSA 90°  
NOT ADJUSTABLE SQUARING ARM 90°

CODE

40.700

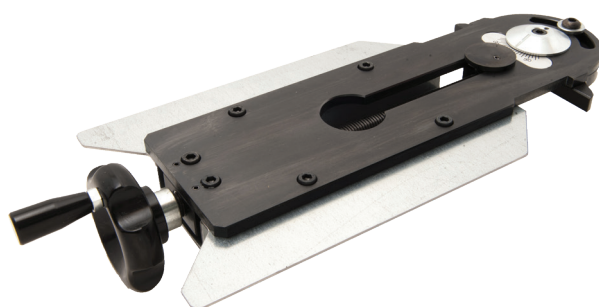

SQUADRA DI RIFERIMENTO STANDARD ORIENTABILE 60° - 120°  
ADJUSTABLE SQUARING ARM 60° - 120°

CODE

40.750

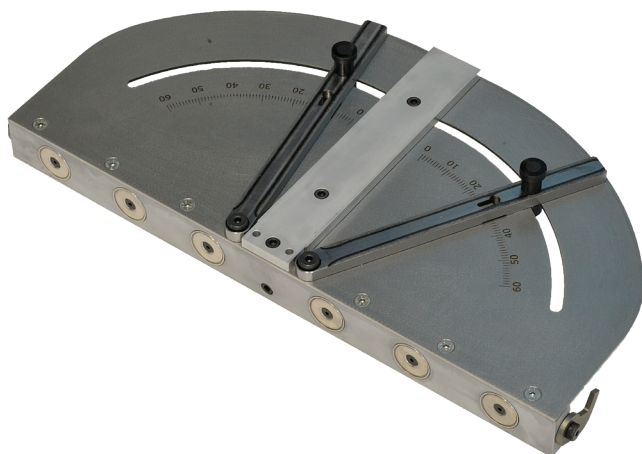

SQUADRA DI RIFERIMENTO MAGNETICA 30° - 90°  
MAGNETIC, DOUBLE ADJUSTABLE SQUARING ARM 30° - 90°

CODE

40.010

KIT PROTEZIONE E PULIZIA  
PROTECTION & CLEANING KIT



1 BOMBOLETTA, 1 SPUGNA ABRASIVA E UN PAIO DI GUANTI  
1 BOTTLE, 1 ABRASIVE SPONGE AND A PAIR OF GLOVES

CODE

40.015



GONIOMETRO DIGITALE CON RISOLUZIONE DI 0,1°  
MISURAZIONE ANGOLI DA 0° A 360°  
DIGITAL ANGLE GAUGE WITH RESOLUTION OF 0,1°  
MEASURING ANGLES FROM 0° TO 360°

CODE

40.016



GONIOMETRO DIGITALE CON RISOLUZIONE DI 0,1°  
MISURAZIONE ANGOLI DA 0° A 360°  
DIGITAL ANGLE GAUGE WITH RESOLUTION OF 0,1°  
MEASURING ANGLES FROM 0° TO 360°

CODE

60.618



STAFFA  
LOWER TOOL CLAMP

CODE

60.619



RONDELLA PER STAFFA  
CLAMP WASHER

# ARMADIO PORTAUTENSILI / TOOLING CABINET

ALTRI COLORI SU RICHIESTA  
OTHER COLORS ON REQUEST



<b>RAL 9005</b>	<b>LEGENDA</b>	L = LUNGHEZZA MAX. STAMPI	Q = N° MAX. STAMPI	C = COLORE	P = PESO
	<b>LEGEND</b>	L = MAX LENGHT TOOLS	Q = MAX TOOLS N°	C = COLOR	P = WEIGHT

CODE	L	Q	P	C
40.645	835 mm	30	200 Kg	■

**AMADA - PROMECAM**

CODE	L	Q	P	C
40.650	835 mm	55	260 Kg	■

**AMADA - PROMECAM**

CODE	L	Q	P	C
40.651	835 mm	55	330 Kg	■

**AMADA - PROMECAM**

CODE	L	Q	P	C
40.652	1100 mm	55	450 Kg	■

**WILA - TRUMPF - BYSTRONIC - LVD**

CODE	L	Q	P	C
40.653	1100 mm	30	300 Kg	■

**WILA - TRUMPF - BYSTRONIC - LVD**

# SILVER LINE

## PUNZONI

## PUNCHES

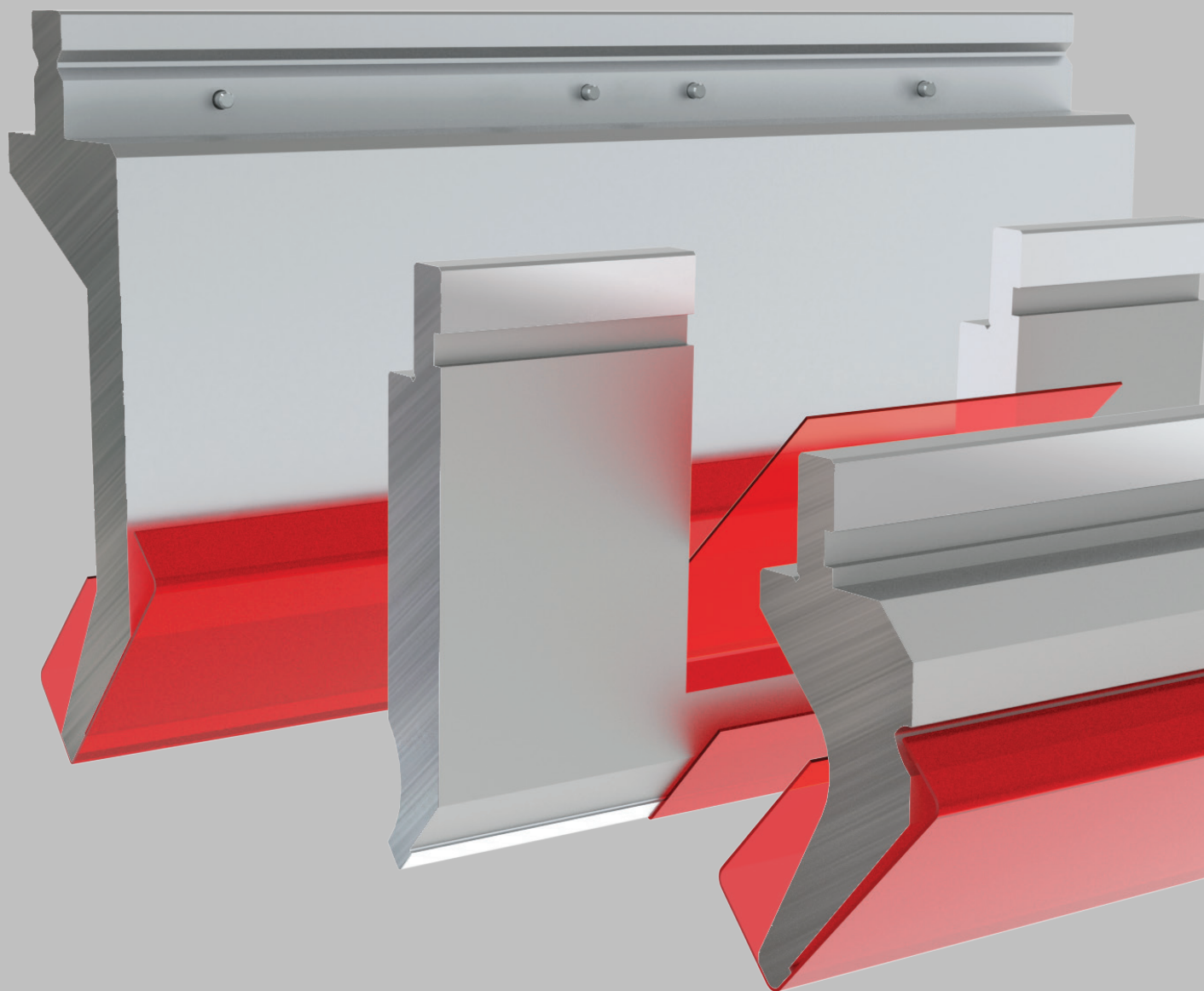

# SILVER LINE

**LAVORAZIONI - MODIFICHE - RICONDIZIONAMENTO UTENSILI**  
**WORKING - MODIFICATION - REFURBISHED TOOLING**

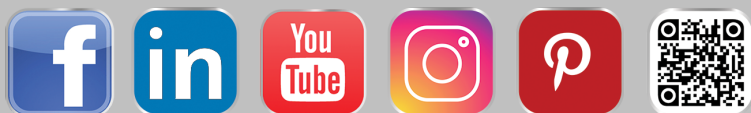

# LAVORAZIONE E MODIFICA PUNZONI / PUNCHES WORKING AND MODIFICATION

<p><b>CODE</b> 70.500</p> <p><b>EURO - BEYELER</b></p>	<p><b>CODE</b> 70.501</p> <p><b>EUROBEYELER - EURO WILA</b></p>	<p><b>CODE</b> 70.502</p> <p><b>DONEWELL - SAFAN - EUROBEYELER</b></p>	<p><b>CODE</b> 70.504</p> <p><b>AMADA ONE TOUCH</b></p>	<p><b>CODE</b> 70.600</p> <p><b>GASPARINI</b></p>											
<p><b>CODE</b> 70.946</p> <p><b>AMADA / PROMECAM</b></p>	<p><b>CODE</b> 70.947</p> <p><b>COLGAR OLD STYLE</b></p>	<p><b>CODE</b> 70.948</p> <p><b>AMADA OLD STYLE</b></p>	<p><b>CODE</b> 70.949</p> <p><b>AMADA - BMB IDRAULIC</b></p>	<p><b>CODE</b> 70.1050</p> <p><b>AMADA - PROMECAM (CLARK)</b></p>											
<p><b>CODE</b> 70.150</p> <p><b>SPINA ROTANTE SU CUSCINETTI - SU RICHIESTA</b> <b>ROLL PIN ON BEARINGS - ON REQUEST</b></p>	<p><b>CODE</b> 70.010</p> <p><b>MODIFICA PUNZONI DI RETTIFICA</b> <b>GRINDING MODIFY OF PUNCHES</b></p>	<p><b>CODE</b> 70.015</p> <p><b>MODIFICHE FINESTRE PUNZONI</b> <b>WINDOWS FOR SHORT U PROFILES</b></p>	<p><b>CODE</b> 70.020</p> <p><b>MODIFICHE FINESTRE PUNZONI</b> <b>WINDOWS FOR SHORT U PROFILES</b></p>												
<p><b>CODE</b> 70.025</p> <p><b>MODIFICHE NERVATURE PUNZONI</b> <b>BEADING IN THE BENDING</b></p>	<p><b>CODE</b> 70.030</p> <p><b>MODIFICA FRESATURA PUNZONI</b> <b>MILLING MODIFY OF PUNCHES</b></p>	<table border="1"> <thead> <tr> <th>CODE</th> <th>TYPE</th> </tr> </thead> <tbody> <tr> <td>70.035</td> <td>A - B - C - D</td> </tr> <tr> <td colspan="2"> <p>SCARPETTA SINGOLA PUNZONI SPECIAL SINGLE HORN PUNCHES</p> </td> </tr> <tr> <th>CODE</th> <th>TYPE</th> </tr> <tr> <td>70.035</td> <td>E - F - G - H</td> </tr> <tr> <td colspan="2"> <p>SCARPETTA DOPPIA PUNZONI SPECIAL DOUBLE HORN PUNCHES</p> </td> </tr> </tbody> </table>	CODE	TYPE	70.035	A - B - C - D	<p>SCARPETTA SINGOLA PUNZONI SPECIAL SINGLE HORN PUNCHES</p>		CODE	TYPE	70.035	E - F - G - H	<p>SCARPETTA DOPPIA PUNZONI SPECIAL DOUBLE HORN PUNCHES</p>		<p><b>CODE</b> SPECIFICARE LUNGHEZZE 70.040 <b>SPECIFY LENGTHS</b></p> <p><b>FRAZIONATURA SPECIALE PUNZONI - SU RICHIESTA</b> <b>SPECIAL SECTIONING PUNCHES - ON REQUEST</b></p>
CODE	TYPE														
70.035	A - B - C - D														
<p>SCARPETTA SINGOLA PUNZONI SPECIAL SINGLE HORN PUNCHES</p>															
CODE	TYPE														
70.035	E - F - G - H														
<p>SCARPETTA DOPPIA PUNZONI SPECIAL DOUBLE HORN PUNCHES</p>															



# SILVER LINE

## MATRICI

## DIES

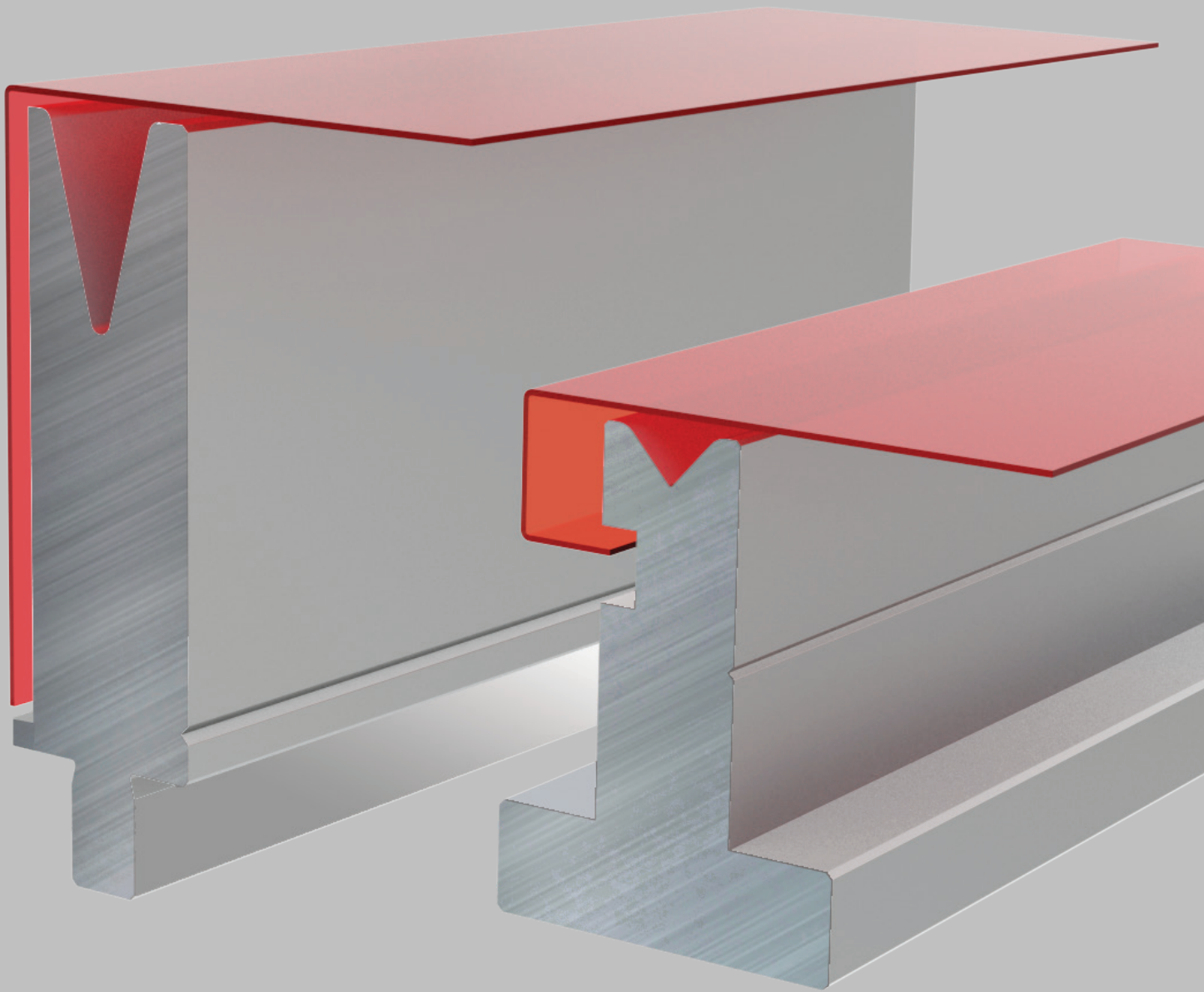

# SILVER LINE

**LAVORAZIONI - MODIFICHE - RICONDIZIONAMENTO UTENSILI**  
**WORKING - MODIFICATION - REFURBISHED TOOLING**



# LAVORAZIONE E MODIFICA MATRICI / DIES WORKING AND MODIFICATION

**CODE**  
70.050

MODIFICA MATRICI DI RETTIFICA  
GRINDING MODIFY OF DIES

**CODE**  
70.060

MODIFICA MATRICI DI FRESATURA  
MILLING MODIFY OF DIES

**CODE**  
70.900

SCANALATURA V-LOCK X MATRICI WILA  
SAFETY GROOVE V-LOCK FOR WILA DIES

**CODE** FRAZIONATURA MATRICI SU RICHIESTA  
70.070 DIES SECTIONED ON REQUEST

FRAZIONATURA SPECIALE MATRICI  
SPECIAL SECTIONING OF DIES

SPECIFICARE LUNGHEZZE  
SPECIFY LENGTHS

**CODE**  
60.100

INSERTO + MODIFICA  
BAR + MODIFICATION

AMADA / WILA - BYSTRONIC

**CODE**  
60.150

INSERTO + MODIFICA  
BAR + MODIFICATION

AMADA / LVD

**CODE**  
60.200

INSERTO + MODIFICA  
BAR + MODIFICATION

AMADA / AMERICAN

# GOLD LINE

## UTENSILI SPECIALI

## SPECIAL TOOLS

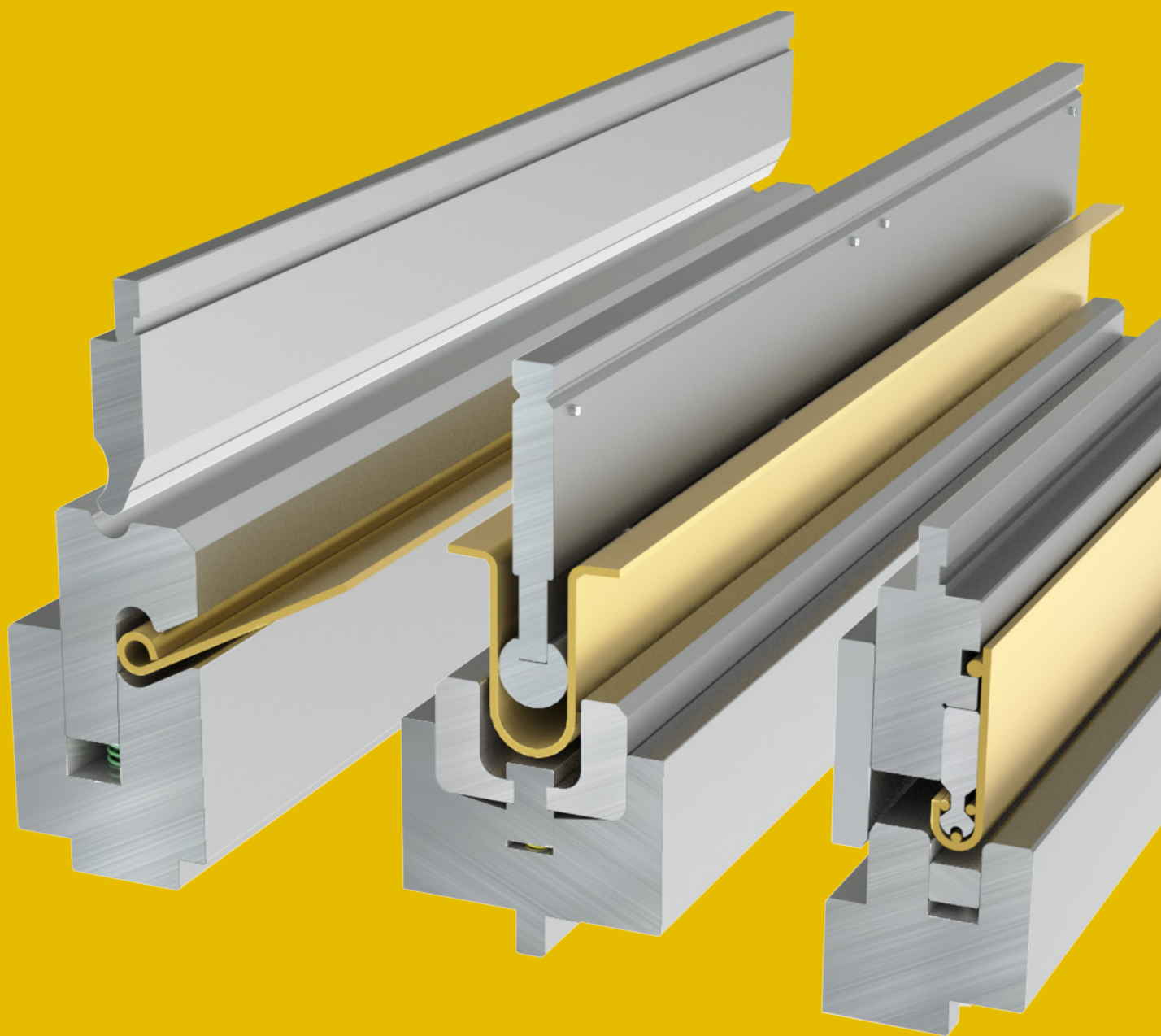

## GOLD LINE

**UTENSILI SPECIALI PER TUTTE LE PRESSE**  
**SPECIAL TOOLING FOR ALL PRESS BRAKES**



# UTENSILI SPECIALI / SPECIAL TOOLING



**GROUP - A /** STAMPI SPECIALI MONOLITICI - DIMENSIONI MASSIME: PUNZONE 140mm x 60mm - MATRICE 120mm x 100mm  
 MONOLITHIC SPECIAL TOOLS - MAX. DIMENSIONS: PUNCH 140mm x 60mm / DIE 120mm x 100mm

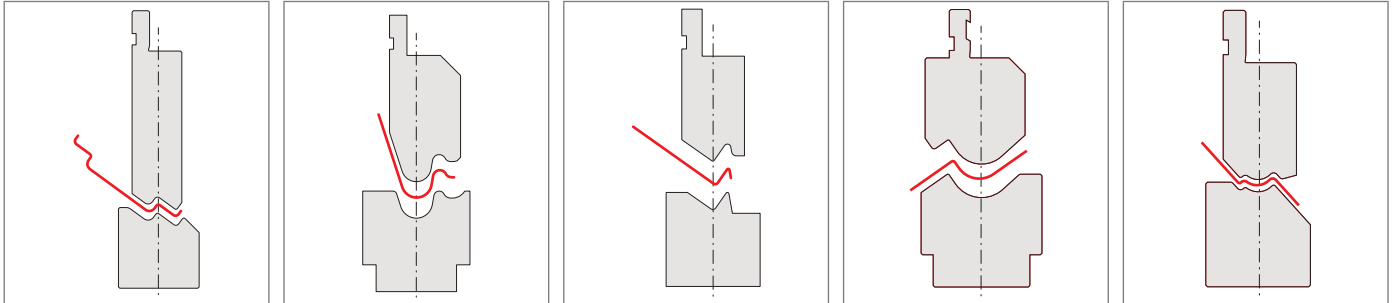

CONSEGNA: 7 SETTIMANE DA RICEVIMENTO ORDINE / DELIVERY TIME: 7 WORKING WEEKS FROM DATA ORDER

**GROUP - B /** STAMPI SPECIALI CON INSERTI REGISTRABILI - DIMENSIONI MASSIME: PUNZONE 140mm x 60mm - MATRICE 120mm x 100mm  
 SPECIAL TOOLING WITH ADJUSTABLE INSERTS - MAX. DIMENSIONS: PUNCH 140mm x 60mm / DIE 120mm x 100mm

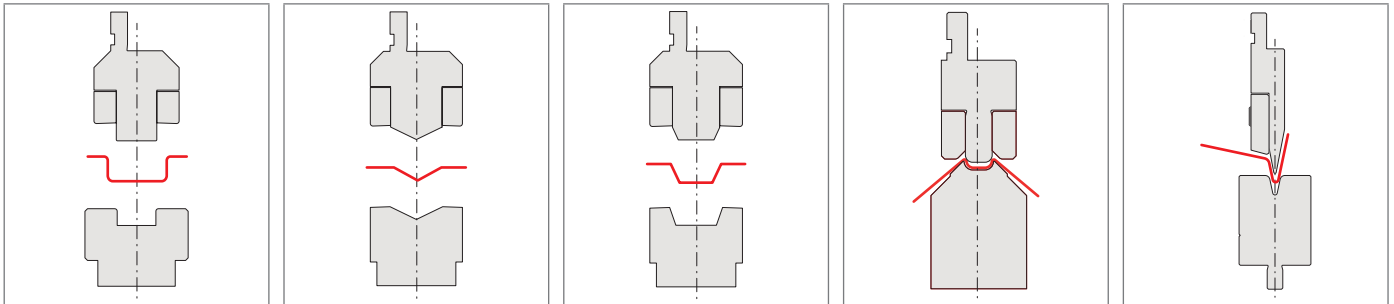

CONSEGNA: 7 SETTIMANE DA RICEVIMENTO ORDINE / DELIVERY TIME: 7 WORKING WEEKS FROM DATA ORDER

**GROUP - C /** STAMPI SPECIALI CON PREMILAMIERA - DIMENSIONI MASSIME: PUNZONE 140mm x 60mm - MATRICE 120mm x 100mm  
 SPECIAL TOOLING WITH COUNTERHOLDER - MAX. DIMENSIONS: PUNCH 140mm x 60mm / DIE 120mm x 100mm

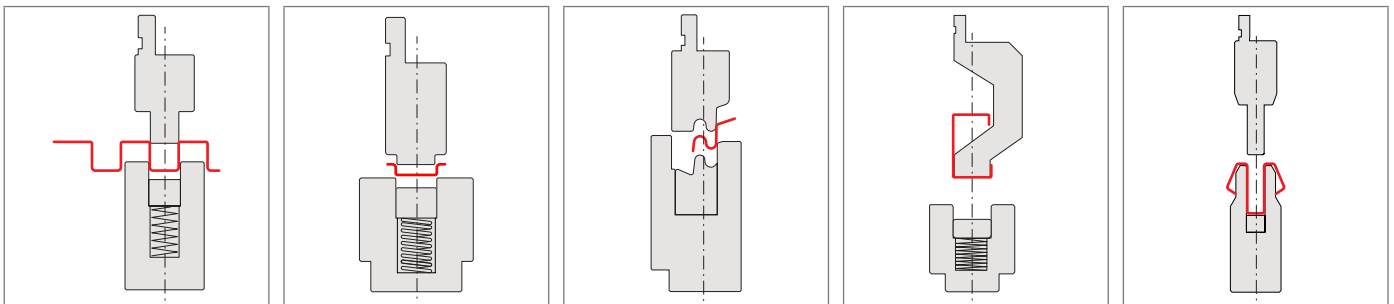

CONSEGNA: 8 SETTIMANE DA RICEVIMENTO ORDINE / DELIVERY TIME: 8 WORKING WEEKS FROM DATA ORDER

**GROUP - D /** STAMPI SPECIALI CON INSERTI E PREMILAMIERA - DIMENSIONI MASSIME: PUNZONE 140mm x 60mm - MATRICE 120mm x 100mm  
 SPECIAL TOOLING WITH INSERT AND COUNTERHOLDER - MAX. DIMENSIONS: PUNCH 140mm x 60mm / DIE 120mm x 100mm

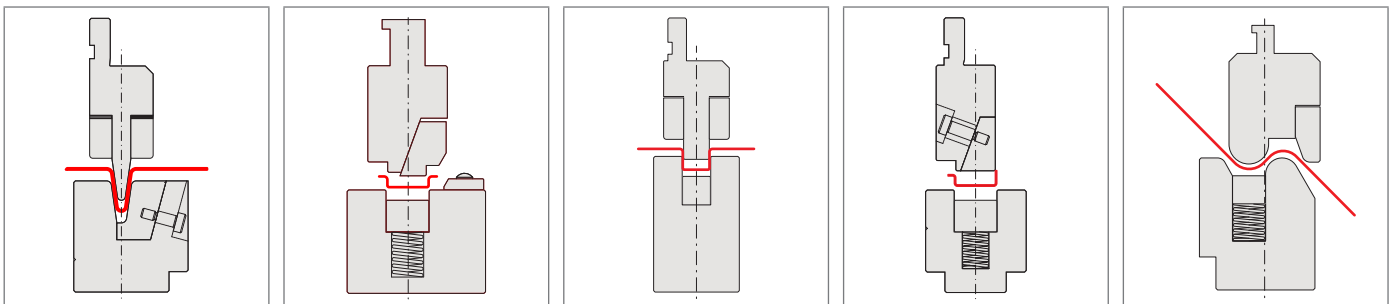

CONSEGNA: 8 SETTIMANE DA RICEVIMENTO ORDINE / DELIVERY TIME: 8 WORKING WEEKS FROM DATA ORDER

# UTENSILI SPECIALI / SPECIAL TOOLING

## GROUP - E / PIEGASCHIACCIA SPECIALI - DIMENSIONI MASSIME: PUNZONE 140mm x 60mm - MATRICE 120mm x 100mm SPECIAL HEMMING TOOLS - MAX. DIMENSIONS: PUNCH 140mm x 60mm / DIE 120mm x 100mm

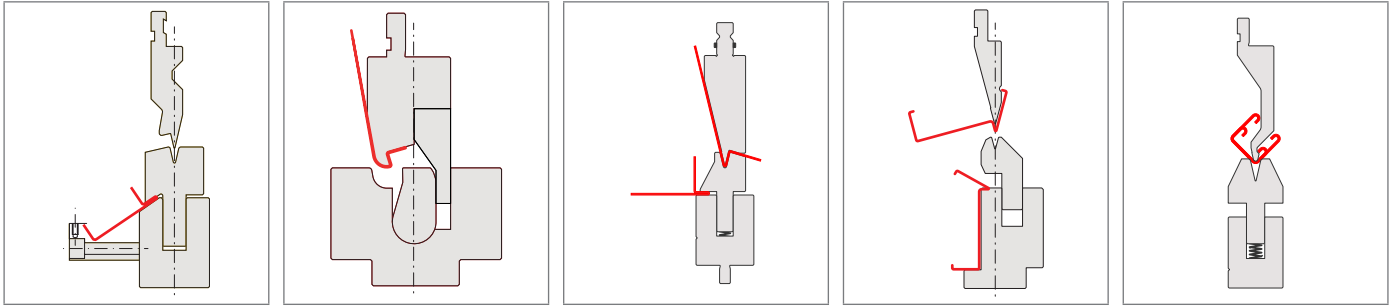

CONSEGNA: 8 SETTIMANE DA RICEVIMENTO ORDINE / DELIVERY TIME: 8 WORKING WEEKS FROM DATA ORDER

## GROUP - F / STAMPI SPECIALI CON CINEMATISMO ED INSERTI BASCULANTI - DIMENSIONI MASSIME: PUNZONE 140mm x 60mm - MATRICE 120mm x 100mm SPECIAL TOOLING WITH CAM MECHANISM - MAX. DIMENSIONS: PUNCH 140MM X 60MM / DIE 120MM X 100MM

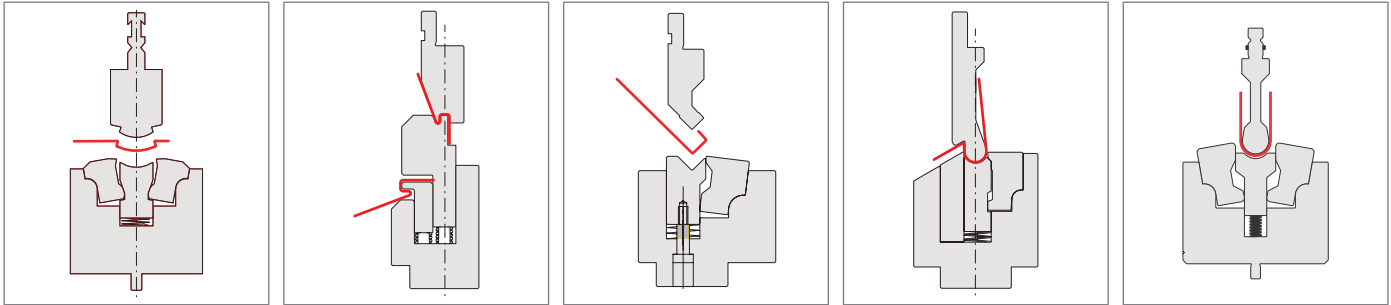

CONSEGNA: 10 SETTIMANE DA RICEVIMENTO ORDINE / DELIVERY TIME: 10 WORKING WEEKS FROM DATA ORDER

## GROUP - G1 / STAMPI SPECIALI PER CERNIERE DI PICCOLE DIMENSIONI (Ø5 / Ø8 - DIAMETRO INTERNO) SPECIAL HINGE TOOLS OF SMALL SIZE (Ø5 / Ø8 - INSIDE DIAMETER)

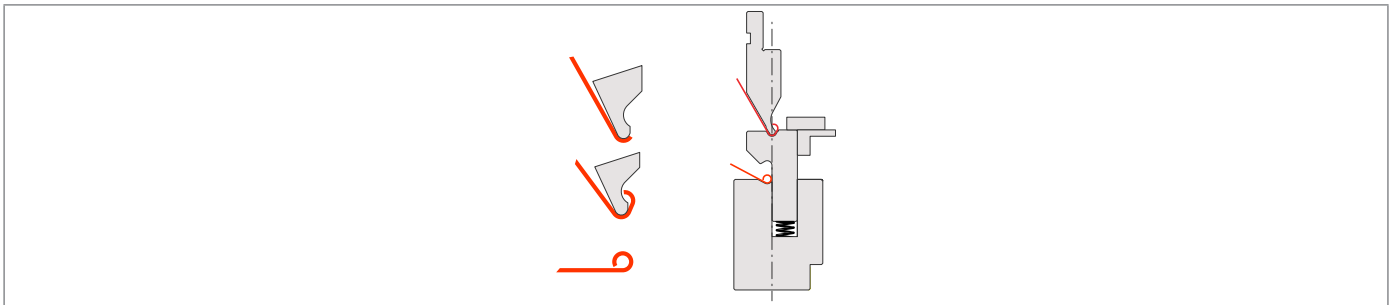

CONSEGNA: 8 SETTIMANE DA RICEVIMENTO ORDINE / DELIVERY TIME: 8 WORKING WEEKS FROM DATA ORDER

## GROUP - G2 / STAMPI SPECIALI PER CERNIERE DI MEDIE DIMENSIONI (Ø9 / Ø12 - DIAMETRO INTERNO) SPECIAL HINGE TOOLS OF MID SIZE (Ø9 / Ø12 - INSIDE DIAMETER)

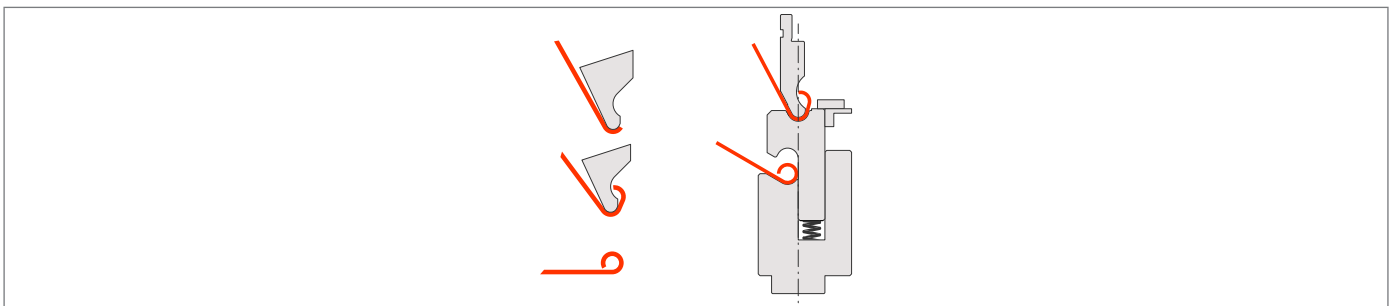

CONSEGNA: 8 SETTIMANE DA RICEVIMENTO ORDINE / DELIVERY TIME: 8 WORKING WEEKS FROM DATA ORDER

## GROUP - G3 / STAMPI SPECIALI PER CERNIERE DI GRANDI DIMENSIONI (Ø13 / Ø16 - DIAMETRO INTERNO) SPECIAL HINGE TOOLS OF BIG SIZE (Ø13 / Ø16 INSIDE DIAMETER)

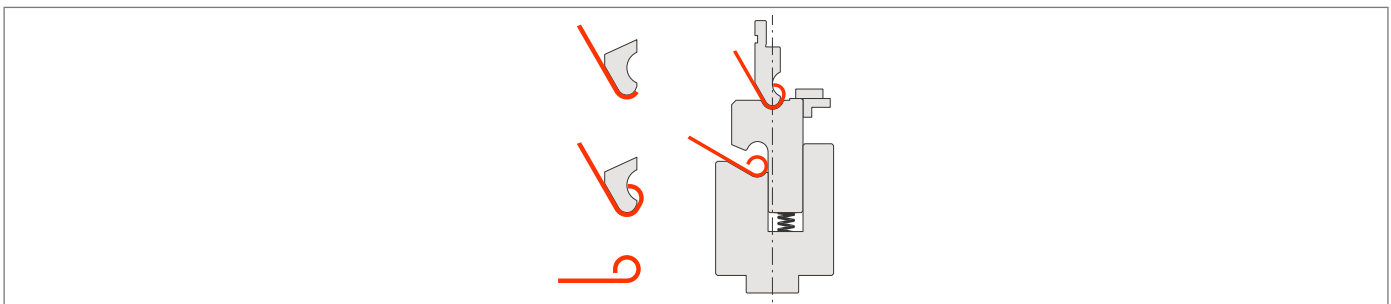

CONSEGNA: 8 SETTIMANE DA RICEVIMENTO ORDINE / DELIVERY TIME: 8 WORKING WEEKS FROM DATA ORDER



🏠 Tecnostamp s.r.l.

📍 Via Vittime della Pertite, 71 - Piacenza - 29121 - Italia

☎ +39 0523 499712 - Fax +39 0523 497020

✉ tecnostamp@tecnostamp.it

📄 P.IVA 12988040155 - C.F. 00326630332

---

---

---

---

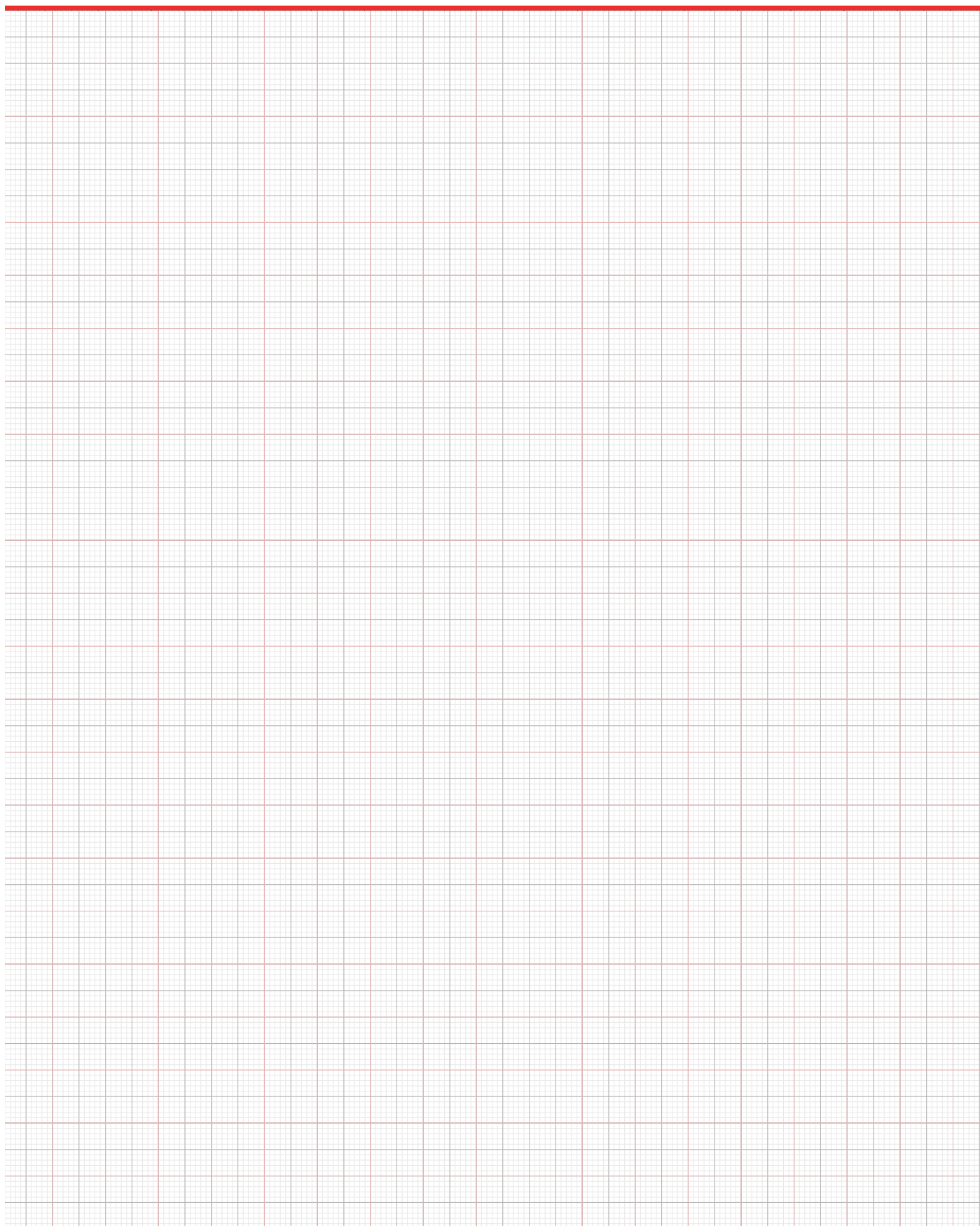

# I NOSTRI CATALOGHI - OUR CATALOGS

AMADA  
PROMECAM



RED LINE

TRUMPF



BLUE LINE

WILA



PLATINUM LINE

BYSTRONIC  
BEYELER



ORANGE LINE

LVD



BLACK LINE

AJIAL  
AMERICAN  
COLGAR  
COLLY  
HÄMMERLE  
EHT  
NEWTON  
WEINBRENNER



RAINBOW LINE

BLADES  
HOLDERS  
RADIUS



SKY LINE

NO  
MARKING  
TOOLS



CORAL LINE

ADAPTERS  
FOR ALL  
PRESS  
BRAKES



MAGENTA LINE

SHEAR  
BLADES



YELLOW LINE

ACCESSORIES  
FOR ALL  
PRESS  
BRAKES



GREEN LINE

WORKING  
MODIFICATION  
REFURBISHED  
TOOLING



SILVER LINE

SPECIAL  
TOOLING  
FOR ALL PRESS  
BRAKES



GOLD LINE

I CATALOGHI SONO DISPONIBILI SUL SITO WEB  
THE CATALOGS ARE AVAILABLE ON THE WEBSITE  
[WWW.TECNOSTAMP.EU](http://WWW.TECNOSTAMP.EU)



SCARICA LA NOSTRA APP PER IOS O ANDROID  
DOWNLOAD OUR APP FOR IOS OR ANDROID

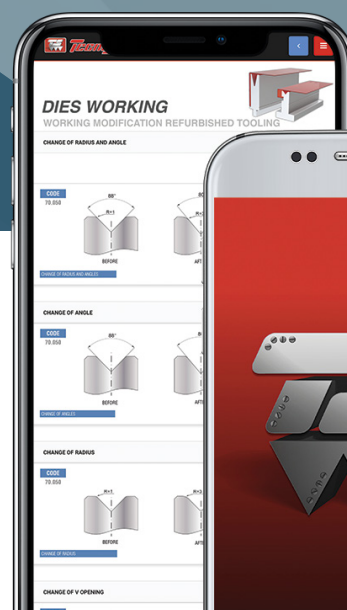

# MECOS

Albert Einstein, nº 6  
08940 Cornellá - Barcelona  
934 740 771                      mecos@mecos.es



Via Vittime della Pertite,71  
29121 Piacenza ITALIA  
Tel +39 0523 499712 - Fax +39 0523 497020  
[www.tecnostamp.eu](http://www.tecnostamp.eu) - [tecnostamp@tecnostamp.it](mailto:tecnostamp@tecnostamp.it)