



# MPK10

ALIMENTADA POR BATERÍA



## MANDO A DISTANCIA



- ✓ Proporcional y preciso
- ✓ Diseño intuitivo
- ✓ Batería de repuesto incorporada

## TRASLACIÓN HACIA ADELANTE Y HACIA ATRÁS EN MODO REMOTO



## +CONTROL POR CABLE

- ✓ Diseño intuitivo

## GANCHO DE 990 KG



## CARACTERÍSTICAS ESPECIALES



- ✓ Plúmin de 990 kg
- ✓ Contrapeso extraíble
- ✓ Caja de herramientas grande
- ✓ Bomba de vacío incorporada
- ✓ Puerto USB para carga de teléfono

## ROTACIÓN DEL MANIPULADOR A 360°

## PLUMA PRINCIPAL

- ✓ Capacidad máx. 990 kg
- ✓ Acero de alta resistencia
- ✓ 2 extensiones hidráulicas



## MANIPULADOR DE CRISTALES DE 990 KG



## MANIPULADOR DE CRISTALES DE 600 KG



## ROTACIÓN DE +/-9°

## ESTABILIZADORES LATERALES



## BATERÍA DE LARGA DURACIÓN



- ✓ Cargador de 220 V
- ✓ Cargador de 110 V 

## RUEDAS



- ✓ Ruedas gemelas disponibles
- ✓ Neumáticos blancos antimarcas disponibles





## DIMENSIONES (mm)



ESCANEAR PARA BUSCAR  
MÁS DATOS TÉCNICOS



	Kg
MPK10	1045
Contrapeso	230
JVM10	165



Madrid 918951758  
www.transgruas.com  
info@transgruas.com

Barcelona 938498388  
Valencia 961344394



## GRÁFICO DE CARGA CON MANIPULADOR DE 990 KG (m - kg)

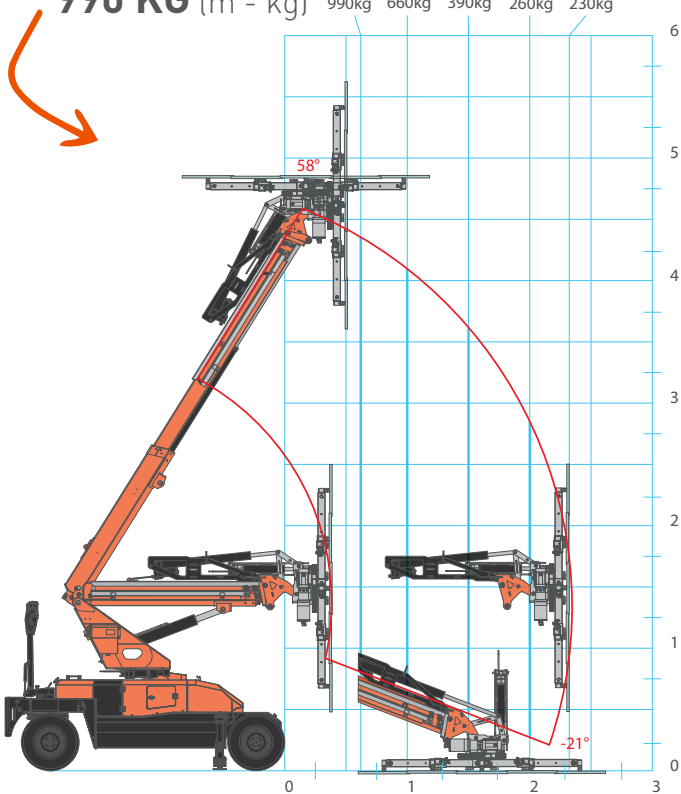

## GRÁFICO DE CARGA CON PLUMÍN (m - kg)

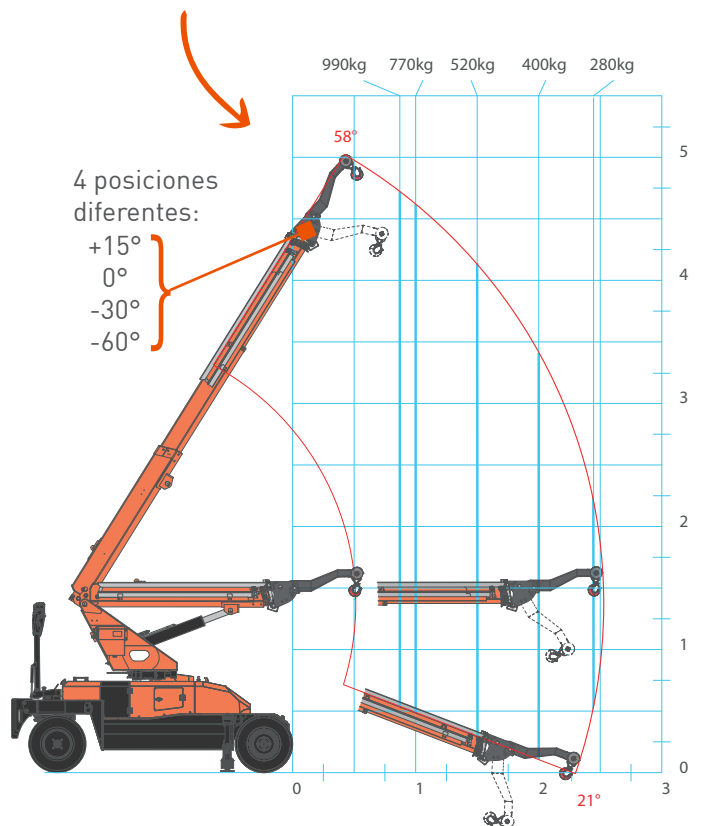

## ACCESORIOS

### JVM10EV

Manipulador de cristales de 990 kg

### JVM06EV

Manipulador de cristales de 600 kg

### PLUMÍN de 990 kg

V02.23

