



Técnicas Aragonesas Salazar, s.a.



C10T.10/ C10T.12



For illustration purpose only



OIL COUNTRY LATHES

STANDART MACHINE SPECIFICATION

STANDART MACHINE SPECIFICATION		Unit	C10T.10	C10T.12
CAPACITY	Height of centers	mm	400	
	Swing over bed	mm	800	
	Swing over cross slide	mm	560	
	Swing in gap	mm	990	
	Width of bed	mm	560	
	Distance between centers	mm	1500;2000;3000;4000;5000;6000	
SPINDLE	Spindle nose DIN 55026 – ANSI B5.9	No	A20 – A2.20	
	Spindle bore	mm	260	315
	Spindle taper	Metric	318	
HEAD STOCK	Number of spindle speeds		12	
	Spindle speed ranges	rpm	8-400 (10-480)	
	Main motor power	kw	11 (15)	
FEEDS	Number of feeds		152	
	Longitudinal feed range	mm/rev	0,039 – 15	
	Cross feed range	mm/rev	0,02 – 7,5	
THREADS	Number of threads		76	
	Metric thread range	mm	0,5 – 150	
	Inch thread range	Tpi	60 – 1/5	
	Module thread range	Module	0,125 – 37,5	
	DP thread range	DP	240 – 4/5	
CARRIAGE	Cross slide travel	mm	410	
	Top slide travel	mm	150	
TAIL STOCK	Quill diameter	mm	105	
	Quill taper	Morse	No.6	
	Quill travel	mm	225	
WEIGHT	For DBC 2000 mm	kg	6000	6100



For illustration purpose only



OIL COUNTRY LATHES

STANDART MACHINE SPECIFICATION

		Unit	C10T.14
CAPACITY	Height of centers	mm	510
	Swing over bed	mm	1020
	Swing over cross slide	mm	780
	Swing in gap	mm	1210
	Width of bed	mm	560
	Distance between centers	mm	1500;2000;3000;4000;5000;6000
SPINDLE	Spindle nose DIN 55026	No	A2.20
	Spindle bore	mm	358
HEAD STOCK	Number of spindle speeds		12
	Spindle variable speed sub-ranges	rpm	6,3 – 315
	Main motor power	kw	18,5
FEEDS	Number of feeds		152
	Longitudinal feed range	mm/rev	0,039 – 15
	Cross feed range	mm/rev	0,02 – 7,5
THREADS	Number of threads		4x64
	Metric thread range	mm	0,5 – 150
	Inch thread range	Tpi	60 – 1/5
	Module thread range	Module	0,125 – 37,5
	DP thread range	DP	240 – 4/5
CARRIAGE	Cross slide travel	mm	510
	Top slide travel	mm	280
TAIL STOCK	Quill diameter	mm	105
	Quill taper	Morse	No.6
	Quill travel	mm	225
WEIGHT	For DBC 2000 mm	kg	7100

LT500M



For illustration purpose only



CNC LATHES

STANDART MACHINE SPECIFICATION

		Unit	LT500
CAPACITY	Height of centers	mm	250
	Swing over bed	mm	500
	Swing over cross slide	mm	300
	Width of bed	mm	400
	Distance between centers	mm	960; 1460; 1960
SPINDLE	Spindle nose DIN 55027	No	8
	Front bearing diameter	mm	120
	Spindle bore	mm	72
	Spindle taper	Metric	80
HEAD STOCK	Number of spindle speeds		3
	I - Range	rpm	20 - 100
	II - Range	rpm	80 - 400
	III - Range		400 - 2000
TRAVELS AND FEEDS	Longitudinal feed (Z-axis)	m/min	8 (max)
	Lateral feed (X-axis)	m/min	8 (max)
	Rapid traverse (Z and X-axis)		8 (max)
	Cross slide maximum travel	mm	270
BALL SCREW	Z-axis	mm	40 x 10
	X-axis	mm	32 x 5
TAILSTOCK	Quill diameter	mm	90
	Quill travel	mm	230
	Quill taper	Morse	5
DRIVES	Main drive power	kW	11 (7,5)
	Z-axis servo drive power	kW/N.m	1,5/8
	X-axis servo drive power	kW/N.m	0,75/4
	Spindle maximum torque	N.m	1120
	Z-axis tow strength	daN	1200
	X-axis tow strength	daN	500
TOOL HOLER	Vertical turret "PRAGATI"		BTP - 63/8
CNC SYSTEM			Siemens
WEIGHT	For DBC 2000 mm	kg	3600

CNC System and servo drives available also: Heidenhain; Fanuc; Fagor

LT580



For illustration purpose only



CNC LATHES

STANDART MACHINE SPECIFICATION

		Unit	LT580
CAPACITY	Height of centers	mm	290
	Swing over bed	mm	580
	Swing over cross slide	mm	380
	Width of bed	mm	400
	Distance between centers	mm	885;1385;1885;2885;3885;4885
SPINDLE	Spindle nose DIN 55027	No	8
	Front bearing diameter	mm	120
	Spindle bore	mm	72
	Spindle taper	Metric	80
HEAD STOCK	Number of spindle speed		3
	I-Range	rpm	25 – 100
	II-Range	rpm	100 - 400
	III-Range	rpm	500 - 2000
TRAVELS AND FEEDS	Longitudinal feed (Z-axis)	m/min	8 (max)
	Lateral feed (X-axis)	m/min	8 (max)
	Rapid traverse (Z and X-axis)	m/min	8 (max)
	Cross slide maximum travel	mm	290
BALL SCREW	Z-axis	mm	50x10
	X-axis	mm	32x5
TAILSTOCK	Quill Diameter	mm	90
	Quill Travel	mm	230
	Quill internal taper	Morse	5
DRIVES	Main drive power	kW	11kW (AT160M4)
	Z-axis servo drive power	kW/N.m	16 N.m (3,3kW) (1FK7083)
	X-axis servo drive power	kW/N.m	11 N.m (2,29kW) (1FK7063)
	Spindle maximum torque	N.m	1120
	Z-axis tow strength	daN	1450
	X-axis tow strength	daN	1050
TOOL HOLER	Quick change type		MC
CNC SYSTEM			Siemens
WEIGHT	For DBC 1885 mm	kg	3800

CNC System and servo drives available also: Heidenhain;Fanuc;Fagor



For illustration purpose only



CNC LATHES

STANDART MACHINE SPECIFICATION

		Unit	LT660	LT760	LT860
CAPACITY	Height of centers	mm	330	380	430
	Swing over bed	mm	660	760	860
	Swing over cross slide	mm	420	520	620
	Width of bed	mm	560		
	Distance between centers	mm	1410;1910;2910;3910;4910;5910	1350;1850;2850; 3850;4850;5850	
SPINDLE	Spindle nose DIN 55027	No	11	11	
	Front bearing diameter	mm	140	170	
	Spindle bore	mm	103	132	
	Spindle taper	Metric	120	140	
HEAD STOCK	Number of spindle speed		3	3	
	I-Range	rpm	9 – 55	7- 42	
	II-Range	rpm	37 - 220	8 – 7028 - 1700	
	III-Range	rpm	220-1320	8 – 700165 1015	
TRAVELS AND FEEDS	Longitudinal feed (Z-axis)	m/min	8 (max)		
	Lateral feed (X-axis)	m/min	8 (max)		
	Rapid traverse (Z and X-axis)	m/min	8 (max)		
	Cross slide maximum travel	mm	430		
BALL SCREW	Z-axis	mm	50x10		
	X-axis	mm	32x5		
TAILSTOCK	Quill Diameter	mm	105		
	Quill Travel	mm	225		
	Quill internal taper	Morse	6		
DRIVES	Main drive power	kW	15Kw (AT160L4)	18,5kW(AT180M4)	
	Z-axis servo drive power	Kw/N.m	18 N.m (3,77kW) (1FK7100)		
	X-axis servo drive power	kw/N.m	11 N.m (2,29kW) (1FK7063)		
	Spindle maximum torque	N.m	2000	2250	
	Z-axis tow strength	daN	1250		
	X-axis tow strength	daN	1050		
TOOL HOLER	Quick change type		MC		
CNC SYSTEM			Siemens		
WEIGHT	For DBC 3000 mm	kg	5700	6060	6300

CNC System and servo drives available also: Heidenhain;Fanuc;Fagor



For illustration purpose only



CNC LATHES

STANDART MACHINE SPECIFICATION		Unit	LTC10T.10	LTC10T.12
CAPACITY	Height of centers	mm	400	
	Swing over bed	mm	800	
	Swing over cross slide	mm	560	
	Width of bed	mm	560	
	Distance between centers	mm	1500;2000;3000;4000;5000;6000	
SPINDLE	Spindle nose DIN 55026	No	A 20 / A2 20	
	Front bearing diameter	mm	380	
	Spindle bore	mm	260	315
	Number of spindle speed		4	
HEAD STOCK	I-Range	rpm	8 – 40	
	II-Range	rpm	16 – 80	
	III-Range	rpm	40 - 200	
	IV-Range	rpm	80 - 400	
TRAVELS AND FEEDS	Longitudinal feed (Z-axis)	m/min	8 (max)	
	Lateral feed (X-axis)	m/min	8 (max)	
	Rapid traverse (Z and X-axis)	m/min	8 (max)	
	Cross slide maximum travel	mm	390	
BALL SCREW	Z-axis	mm	50x10	
	X-axis	mm	32x5	
TAILSTOCK	Quill Diameter	mm	105	
	Quill Travel	mm	225	
	Quill internal taper	Morse	6	
DRIVES	Main drive power	kW	18,5kW (AT180M4)	
	Z-axis servo drive power	Kw/N.m	18 N.m (3,77Kw) (1FK7100)	
	X-axis servo drive power	kw/N.m	11 N.m (2,29kW) (1FK7063)	
	Spindle maximum torque	N.m	3500	
	Z-axis tow strength	daN	1250	
	X-axis tow strength	daN	1050	
TOOL HOLER	Quick change type		MC	
CNC SYSTEM			Siemens	
WEIGHT	For DBC 3000 mm	kg	6100	

CNC System and servo drives available also: Heidenhain;Fanuc;Fagor

LT800/ LT1000/ LT1250



For illustration purpose only



CNC LATHES

STANDART MACHINE SPECIFICATION

		Unit	LT800	LT1000	LT1250
CAPACITY	Height of centers	mm	410	510	635
	Swing over bed	mm	890	1090	1320
	Swing over cross slide	mm	490	690	940
	Width of bed	mm	700		
	Distance between centers	mm	1500;3000;4000;5000;6000		
SPINDLE	Spindle nose DIN 55027	No	15		
	Front bearing diameter	mm	200		
	Spindle bore	mm	155		
	Spindle taper	Metric	160		
HEAD STOCK	Number of spindle speed		4		
	I-Range	rpm	3,7 – 15,6		
	II-Range	rpm	14,7 – 62		
	III-Range	rpm	58 – 250		
	IV-Range	rpm	235 - 1000		
	Longitudinal feed (Z-axis)	m/min	8 (max)		
	Lateral feed (X-axis)	m/min	8 (max)		
	Rapid traverse (Z and X-axis)	m/min	8 (max)		
BALL SCREW	Cross slide maximum travel	mm	525	650	
	Z-axis	mm	63x10		
	X-axis	mm	40x10		
TAILSTOCK	Quill Diameter	mm	125		
	Quill Travel	mm	250		
	Quill internal taper	Morse	6		
DRIVES	Main drive power	kW	30kW (AT180LL4)		
	Z-axis servo drive power	kW/N.m	27 N.m (4,87kW) (1FK7101)		
	X-axis servo drive power	kW/N.m	11 N.m (2,29kW) (1FK7063)		
	Spindle maximum torque	N.m	5000		
	Z-axis tow strength	daN	1600		
	X-axis tow strength	daN	800		
TOOL HOLER	Quick change type		MD1		
CNC SYSTEM			Siemens		
WEIGHT	For DBC 3000 mm	kg	8800	9300	9800

CNC System and servo drives available also: Heidenhain;Fanuc;Fagor

LCC800/ LCC1000/ LCC1250



For illustration purpose only



CNC LATHES

STANDART MACHINE SPECIFICATION		Unit	LCC800	LCC1000	LCC1250
CAPACITY	Height of centers	mm	410	510	635
	Swing over bed	mm	890	1090	1320
	Swing over cross slide	mm	490	690	940
	Width of bed	mm	700		
	Distance between centers	mm	1500;3000;4000;5000;6000		
SPINDLE	Spindle nose DIN 55027	No	15		
	Front bearing diameter	mm	200		
	Spindle bore	mm	155		
	Spindle taper	Metric	160		
HEAD STOCK	Number of spindle speed		2		
	I-Range	rpm	2 – 180		
	II-Range	rpm	8 - 700		
	Longitudinal feed (Z-axis)	m/min	8 (max)		
	Lateral feed (X-axis)	m/min	8 (max)		
	Rapid traverse (Z and X-axis)	m/min	8 (max)		
	Cross slide maximum travel	mm	525	650	
BALL SCREW	Z-axis	mm	63x10		
	X-axis	mm	40x10		
TAILSTOCK	Quill Diameter	mm	125		
	Quill Travel	mm	250		
	Quill internal taper	Morse	6		
DRIVES	Main drive power	kW	30kW (1PH7163)		
	Z-axis servo drive power	kW/N.m	27 N.m (4,87kW) (1FK7101)		
	X-axis servo drive power	kW/N.m	11 N.m (2,29kW) (1FK7063)		
	Spindle maximum torque	N.m	5000		
	Z-axis tow strength	daN	1600		
	X-axis tow strength	daN	800		
TOOL HOLER	Quick change type		MD1		
CNC SYSTEM			Siemens		
WEIGHT	For DBC 3000 mm	kg	8800	9300	9800

CNC System and servo drives available also: Heidenhain;Fanuc;Fagor

LATHE MACHINE OPTIONAL ACCESSORIES

N	OPTIONAL ACCESSORY	SPECIFICATIONS	CU325 CU325RD	C400TM C400TMS	CU400	CU500	CU400M CU400MRD	CU500M CU500MRD	CU580M CU580MRD
1	3-JAW SELF-CENTERING CHUCK	Diameter (mm)	160	200	250	250	250	250	250
2	INDEPENDENT 4-JAW CHUCK	Diameter (mm)	250	320	400	500	400	500	500
3	FACE PLATE	Diameter (mm)	296	320	400	480	400	480	480
4	FOLLOWE REST	Range (mm)	10-70	10-80	15-160	15-200	15-160	15-200	15-200
5	STEADY REST, SMALL SIZE	Range (mm)	10-70	10-100	15-150	15-160	15-160	15-160	15-200
6	STEADY REST, BIG SIZE	Range (mm)	No	No	No	140-280	No	140-280	180-340
7	TAPER TURNING ATTACHM.	+10°	Yes	Yes	Yes	Yes	Yes	Yes	Yes
8	ONE-POSITION LONG. STOP		Yes	Yes	Yes	Yes	Yes	Yes	Yes
9	THREAD DIAL		Yes	Yes	Yes	Yes	Yes	Yes	Yes
10	DRIVE PLATE FOR SPINDLE NOSE DIN 55027		Yes	Yes	Yes	Yes	Yes	Yes	Yes
11	SET OF LATHE DOGS	Ø20; Ø30; Ø40; Ø50; Ø60; Ø80; Ø100	20; 50;	20;30;40;50;60	Full	Full	Full	Full	Full
12	LIVE CENTER	Morse	M3	M4	M5	M5	M5	M5	M5
13	DRILL CHUCK WITH ARBOR	Drill diam. (mm)	13	20	20	20	20	20	20

Remarks : Yes = Available for this model; No = Not available for this model

Steady rest Ø720mm for lathe CU1000 – open type only

Steady rest Ø 700-1000 for lathe CU1410RD - open type only

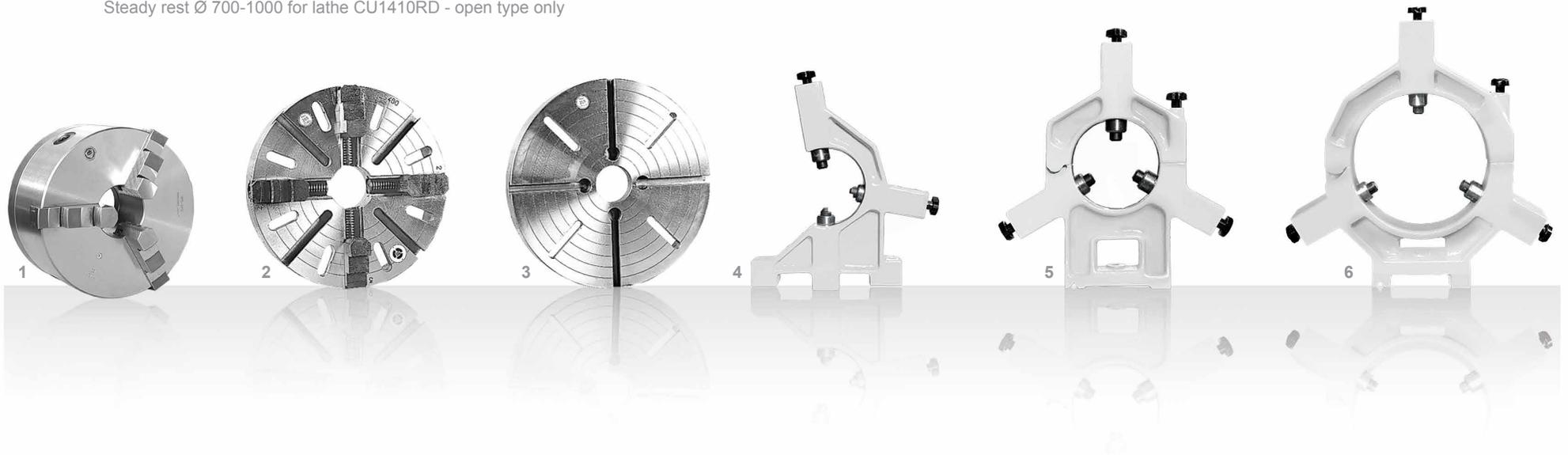

C11MT C11MTS	CU500MT CU500MTRD	CU630 CU630RD	CU730 CU730RD	C10T C10TS	C10TM C10TMS	C10TH C10THS	C10T.10 C10TS.10	C10T.12 C10TS.12	C10T.14 C10TS.14	CU800 CU800RD	CU1000 CU1000RD	CU1250 CU1250RD	CU1410RD
250	315	315	315	315	400	400	500	500	660	500	500	500	630
500	500	600	600	600	760	760	580 Standard	630 Standard	710 Standard	760	1000	1000	1250
480	500	600	600	600	760	760	x	x	x	760	1000	1000	No
15-200	15-200	15-200	15-200	20-200	20-200	20-200	20-200	20-200	20-200	80-300	80-300	80-300	80-300
15-200	15-160	15-200	15-200	20-200	20-200	50-250	20-200	20-200	20-200	50-300	50-300	50-300	80-300
180-340	140-280	180-340	180-430	180-430	180-430 200-520	220-450 420-620	180-430	180-430	180-430	270-520 270-520	270-520 480-720	270-520 480-720 700-950	270-520 470-720 700-1000
Yes	Yes	Yes	Yes	Yes	Yes	Yes	Yes Standard	Yes Standard	Yes Standard	Yes	Yes	Yes	Yes
Yes	Yes	Yes	Yes	Yes	Yes	Yes	Yes	Yes	Yes	No	No	No	Yes
Yes	Yes	Yes	Yes	Yes	Yes	Yes	Yes Standard	Yes Standard	Yes Standard	Yes	Yes	Yes	No
Yes	Yes	Yes	Yes	Yes	Yes	Yes	No	No	No	No	No	No	No
Full	Full	Full	Full	Full	Full	Full	No	No	No	No	No	No	No
M5	M5	M5	M5	M6	M6	M6	M6	M6	M6	M6	M6	M6	MK 7
20	20	20	20	20	20	20	No	No	No	No	No	No	No

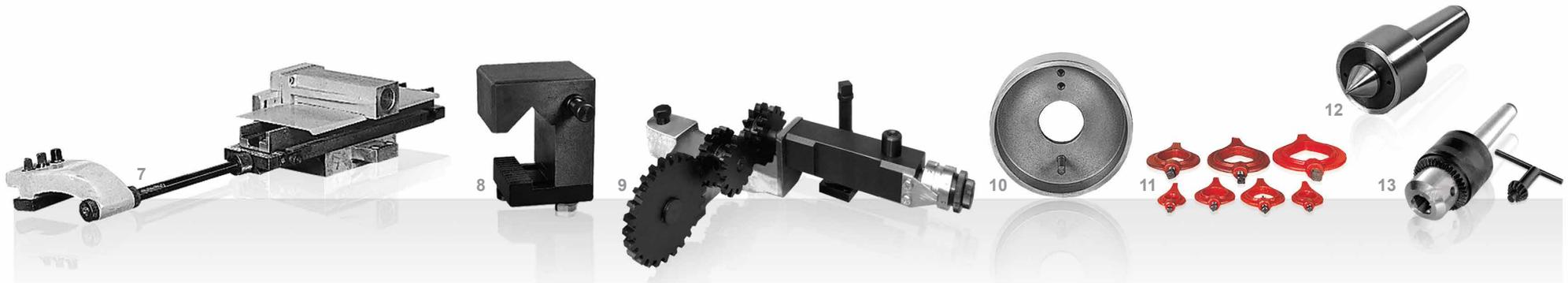



Técnicas Aragonesas Salazar, s.a.



Técnicas Aragonesas Salazar, s.a.

Polígono Ind. Cogullada C/ Jaime Ferrán nº 5 – Edificio Nido 2º piso (Ofic. Agrar Fertilizantes s.a.)
C.P. 50014 Zaragoza (ESPAÑA)
Telf.: +34 976 47 3 3 20 Móvil: +34 630 87 50 77
E-mail: tecarsa@tecarsa.com
Web: www.tecarsa.com