

BCI Cells

Bolted 158mm / 6.2in wide

Eternity Technologies have brought together the latest manufacturing processes and modern design criteria to deliver the Eternity Technologies BCI range of Cells designed to meet the ever changing demands of the Global Motive Power market.

 **Part of our Motive Power range**

Features

Lead-acid vented batteries with liquid electrolyte

Capacity for BCI product range: 180 – 2240Ah

Non-woven tubular sleeving helps to increase productivity while maximising performance

Modern tubular design maximises the active lead material and delivers optimised energy

The latest separator design delivers increased acid volumes and increases acid circulation

Fully insulated terminals



Applications

Forklift Trucks

Electric Vehicles

Cleaning Machines

Lifting platforms

Road vehicles

Tow tractors

Other electric vehicles with high energy/ deep cycle requirements

Compliant with

EN60-254-1 & EN60-254-2
IEC254-1 & IEC254-2

BCI Cells

Positive plate

High energy density tubular positive plate

Separator

Microporous polyethylene separator design delivers increased acid volumes

Sealing washer

Thermoplastic elastomer (TPE) sealing washer utilised for leak free sealing of the terminal

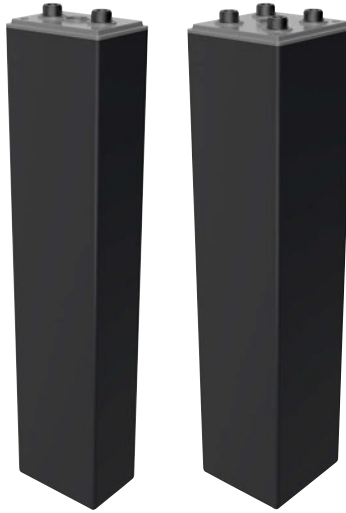

Negative plate

Industry leading negative plate design

Gauntlet

Non-woven, high-capacity polyester gauntlet

Base prism

Rigid polypropylene prism to collect dislodged active material preventing bottom edge shorts

BCI Cells - Weight, Capacity and Dimension Charts

BCI-90		H1 = 523mm / 20.6in H2 = 551mm / 21.7in			
Cell type	Ah (C6)	Weight (kg)	Weight (lb)	Length (in)	Length (mm)
BCI-90-5-ST	180	13.4	29.5	2	51
BCI-90-7-ST	270	18.3	40.3	2.75	70
BCI-90-9-ST	360	23.3	51.4	3.5	89
BCI-90-11-ST	450	28.3	62.4	4.25	108
BCI-90-13-ST	540	33.3	73.4	5	127
BCI-90-15-ST	630	38.4	84.7	5.75	146
BCI-90-17-ST	720	44.3	97.7	6.5	165
BCI-90-19-ST	810	49.3	108.7	7.25	184
BCI-90-21-ST	900	54.3	119.7	8	203
BCI-90-23-ST	990	59.3	130.7	8.75	222
BCI-90-25-ST	1080	64.3	141.8	9.5	241
BCI-90-27-ST	1170	69.4	153.0	10.25	260
BCI-90-29-ST	1260	75.0	165.3	11	279
BCI-90-31-ST	1350	80.0	176.4	11.75	298
BCI-90-33-ST	1440	85.0	187.4	12.5	317

BCI-100		H1 = 599mm / 23.6in H2 = 627mm / 24.7in			
Cell type	Ah (C6)	Weight (kg)	Weight (lb)	Length (in)	Length (mm)
BCI-100-5-ST	200	14.9	32.8	2	51
BCI-100-7-ST	300	20.3	44.8	2.75	70
BCI-100-9-ST	400	25.7	56.7	3.5	89
BCI-100-11-ST	500	31.1	68.6	4.25	108
BCI-100-13-ST	600	36.6	80.7	5	127
BCI-100-15-ST	700	42.2	93.0	5.75	146
BCI-100-17-ST	800	48.9	107.8	6.5	165
BCI-100-19-ST	900	54.4	119.9	7.25	184
BCI-100-21-ST	1000	59.8	131.8	8	203
BCI-100-23-ST	1100	65.3	144.0	8.75	222
BCI-100-25-ST	1200	70.8	156.1	9.5	241
BCI-100-27-ST	1300	76.3	168.2	10.25	260
BCI-100-29-ST	1400	82.7	182.3	11	279
BCI-100-31-ST	1500	88.2	194.4	11.75	298
BCI-100-33-ST	1600	93.6	206.4	12.5	317

BCI-125		H1 = 720mm / 28.3in H2 = 748mm / 29.4in			
Cell type	Ah (C6)	Weight (kg)	Weight (lb)	Length (in)	Length (mm)
BCI-125-5-ST	250	18.0	39.7	2	51
BCI-125-7-ST	375	24.7	54.5	2.75	70
BCI-125-9-ST	500	31.4	69.2	3.5	89
BCI-125-11-ST	625	38.2	84.2	4.25	108
BCI-125-13-ST	750	44.9	99.0	5	127
BCI-125-15-ST	875	51.9	114.4	5.75	146
BCI-125-17-ST	1000	59.8	131.8	6.5	165
BCI-125-19-ST	1125	66.6	146.8	7.25	184
BCI-125-21-ST	1250	73.4	161.8	8	203
BCI-125-23-ST	1375	80.1	176.6	8.75	222
BCI-125-25-ST	1500	86.9	191.6	9.5	241
BCI-125-27-ST	1625	93.7	206.6	10.25	260
BCI-125-29-ST	1750	101.5	223.8	11	279
BCI-125-31-ST	1875	108.3	238.8	11.75	298
BCI-125-33-ST	2000	115.1	253.8	12.5	317

BCI Cells Enhanced Capacity - Weight, Capacity and Dimension Charts

BCI-100 H1 = 523mm / 20.6in H2 = 551mm / 21.7in

Cell type	Ah (C6)	Weight (kg)	Weight (lb)	Length (in)	Length (mm)
BCI-100-5-EC	200	13.1	28.9	2	51
BCI-100-7-EC	300	18.2	40.1	2.75	70
BCI-100-9-EC	400	23.3	51.4	3.5	89
BCI-100-11-EC	500	28.5	62.8	4.25	108
BCI-100-13-EC	600	33.6	74.1	5	127
BCI-100-15-EC	700	38.9	85.8	5.75	146
BCI-100-17-EC	800	44.6	98.3	6.5	165
BCI-100-19-EC	900	49.8	109.8	7.25	184
BCI-100-21-EC	1000	55.0	121.3	8	203
BCI-100-23-EC	1100	60.2	132.7	8.75	222
BCI-100-25-EC	1200	65.4	144.2	9.5	241
BCI-100-27-EC	1300	70.6	155.6	10.25	260
BCI-100-29-EC	1400	76.2	168.0	11	279
BCI-100-31-EC	1500	81.3	179.2	11.75	298
BCI-100-33-EC	1600	86.5	190.7	12.5	317

BCI-140 H1 = 720mm / 28.3in H2 = 748mm / 29.4in

Cell type	Ah (C6)	Weight (kg)	Weight (lb)	Length (in)	Length (mm)
BCI-140-5-EC	280	18.0	39.7	2	51
BCI-140-7-EC	420	25.1	55.3	2.75	70
BCI-140-9-EC	560	32.2	71.0	3.5	89
BCI-140-11-EC	700	39.3	86.6	4.25	108
BCI-140-13-EC	840	46.4	102.3	5	127
BCI-140-15-EC	980	53.7	118.4	5.75	146
BCI-140-17-EC	1120	61.3	135.1	6.5	165
BCI-140-19-EC	1260	68.5	151.0	7.25	184
BCI-140-21-EC	1400	75.6	166.7	8	203
BCI-140-23-EC	1540	82.8	182.5	8.75	222
BCI-140-25-EC	1680	90.0	198.4	9.5	241
BCI-140-27-EC	1820	97.1	214.1	10.25	260
BCI-140-29-EC	1960	104.7	230.8	11	279
BCI-140-31-EC	2100	111.9	246.7	11.75	298
BCI-140-33-EC	2240	119.1	262.6	12.5	317

± 5% weight tolerance
W: 158mm (6.2 inches)
H1: Height over lid
H2: Overall height including connector and bolt
Torque: 23 Nm

Not to scale

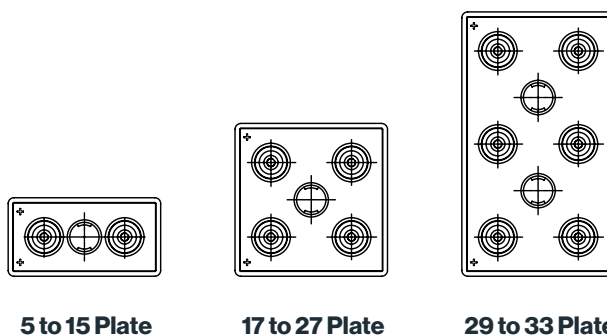
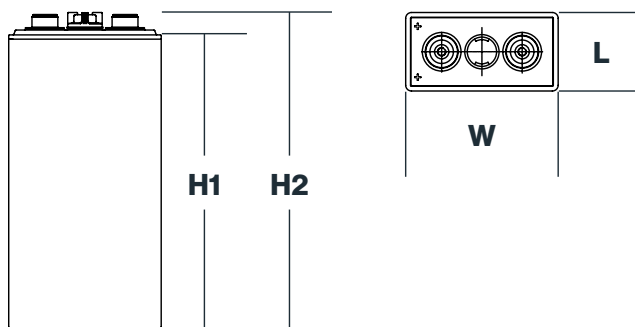

90

Plate capacity (Ah)

5

Number of total plates

ST/EC

Standard / Enhanced Capacity

POWER FOR TOMORROW TODAY

The Eternity Technologies range is built using only the highest quality and most efficient production processes at our state-of-the-art manufacturing centre in the UAE.

It is this innovation, modern design criteria and industry-leading machinery that allows Eternity Technologies to not only meet the needs of the global industrial market with increased reliability but define it for the future.



Service



Accessories



Bloc Batteries



Chargers



Network Power



Motive Power



Eternity Technologies FZ-LLC

Al Jazeera / Al Hamra, PO Box 35102,
Ras Al Khaimah, UAE

Sales & service

info@eternitytechnologies.com

www.eternitytechnologies.com